

# Driveshaft / Axle

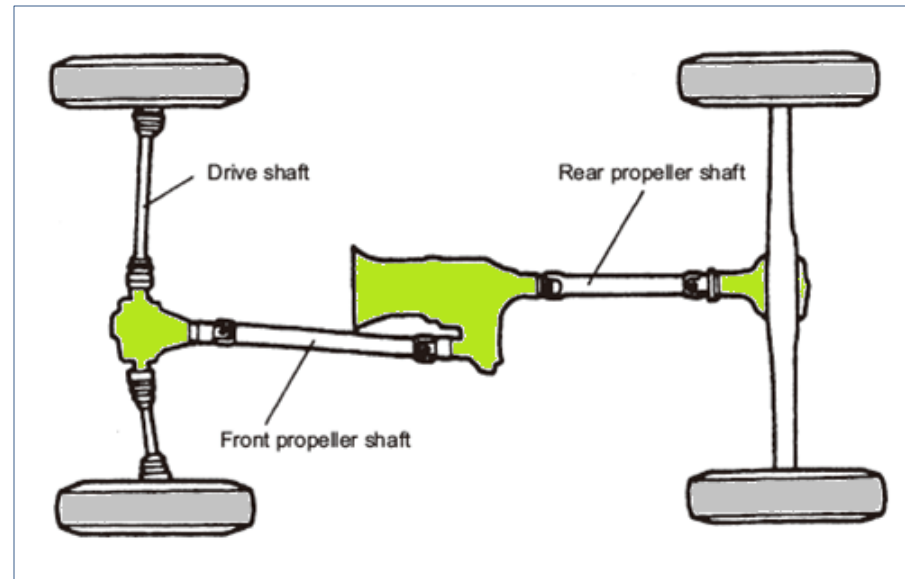

**SUZUKI  
TRAINING ACADEMY**



Driveshaft/axle  
Course code: DS01

Student training manual  
Suzuki Online Training

## Foreword

In this training manual, we will study the basic of drive shafts, propeller shafts and differentials. These components from part of the drive train and transfer the rotational force generated by the engine to the driving wheels.

### Smart manuals



Some sections of this training manual contain videos with detailed information on the topics you are studying. If you are studying this training manual on a PC, look out for the “green play video” symbol on any photo or picture in this manual, click on the green button to watch a video providing you with detailed information on that topic. **Note: Internet connection required.**

This document is intended solely for training purposes only. All vehicle repairs and adjustments must be carried out according to the procedures stipulated in current service manuals and technical bulletins.

## Suzuki Technician curriculum

This training manual is part of the [Non Suzuki Technician to Suzuki Technician curriculum](#). The curriculum consists of the following modules:

1. GE01 Suzuki Introduction
2. GE02 Electrical / Electronics
3. GE03 Diagnostics
4. EN02 Engine Mechanical part I
5. EN03 Engine Mechanical part II
6. EN04 Engine Mechanical part III
7. EN05 Engine Auxiliary systems
8. [DS01 Driveshaft/Axle](#)
9. DS02 Driveshaft/Axle - transfer case
10. BR02 Brake control systems
11. Manual transmission / transaxle
12. CS02 Control system / body electrical
13. CS03 Communication / bus systems

You are currently studying DS02 Driveshaft/Axle Transfer case. This module consists of the following courses:

- [Driveline / Axle](#)
- DS01 Practical Activities

# Table of contents

Topic	Page	Topic	Page
Lesson 1: Drive shafts	5	Rear differential assembly (SN413)	30
Drive shaft function	5	Select the bevel pinion shim	31
Drive shaft structure and operation	5	Adjust bevel gear backlash	33
Constant velocity universal joint	6	Differential symptom diagnosis	35
Tripod joint	7		
Drive shaft components	8		
Checks and maintenance	9		
Lesson 2: Propeller shaft	11		
Propeller shaft structure and operation	12		
Centre bearing	13		
Universal joint	14		
Propeller shaft checks and maintenance	15		
Lesson 3: Differential	19		
Description	20		
Rear differential construction	20		
Front differential construction	21		
Differential operating principle	21		
Final gear	24		
Check and maintenance	26		
Backlash check (FWD)	26		
Teeth contact check	27		

# Lesson 1:

## Driveshaft

### Objectives

At the end of this lesson, you will be able to:

- Define the function of driveshaft.
- Identify the components of drive shafts.
- Define the function of CV joints.
- Perform basic checks and maintenance of the driveshaft and CV joint.

## 1.1 Driveshaft function

The drive shaft is directly connected to the differential and is used for power transmission between the differential and the wheels. It is frequently used in independent suspensions.

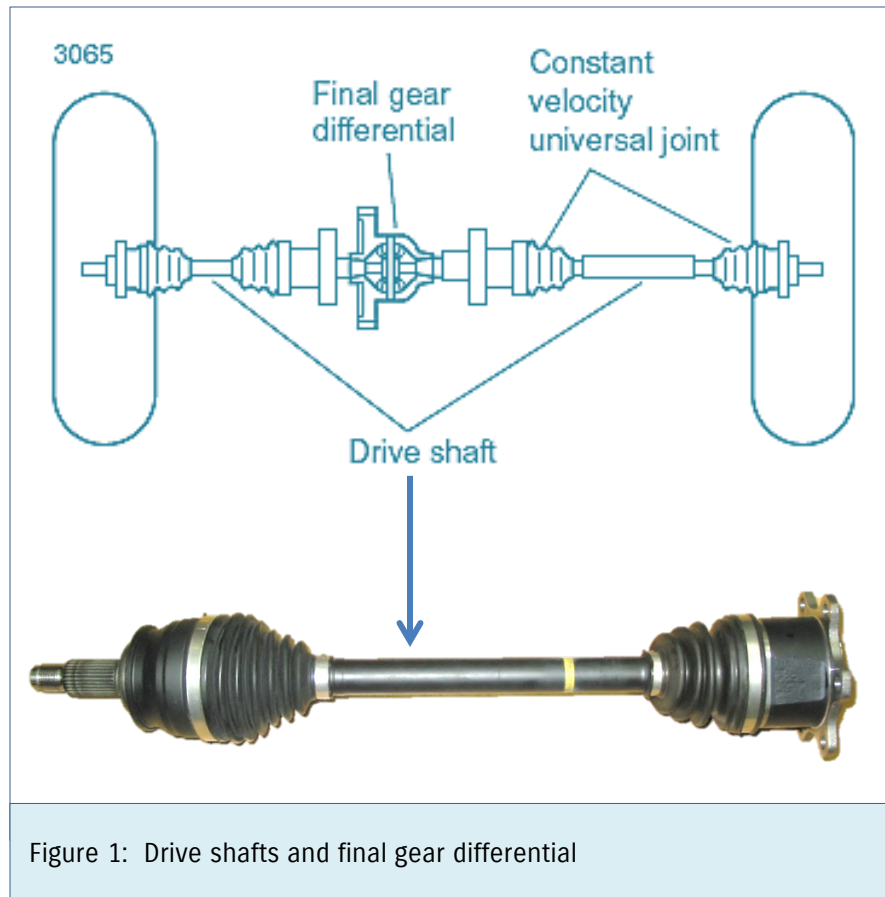

Figure 1: Drive shafts and final gear differential

## 1.2 Structure and operation

### 1.2.1 Drive shaft

Because the drive shaft is subjected to impacts from the road surface and to torque that is amplified by the reduction action of the differential, its twisting strength and rigidity must be many times that of the propeller shaft. For this reason, it is a steel bar and not hollow. To withstand these loads, the constant velocity universal joints on both shaft sides are also made of strong material.

The drive shaft have constant velocity universal joints that can transmit rotation smoothly in different drive angels. A constant velocity universal joint is positioned on the sliding mechanism that absorbs the changes in the length in the axial direction caused by the up-and down movement of the tires while driving. Another constant velocity universal joint also accommodates large changes in the angle when turning because the shaft length is short, or because of up-and down tire movements.

3066

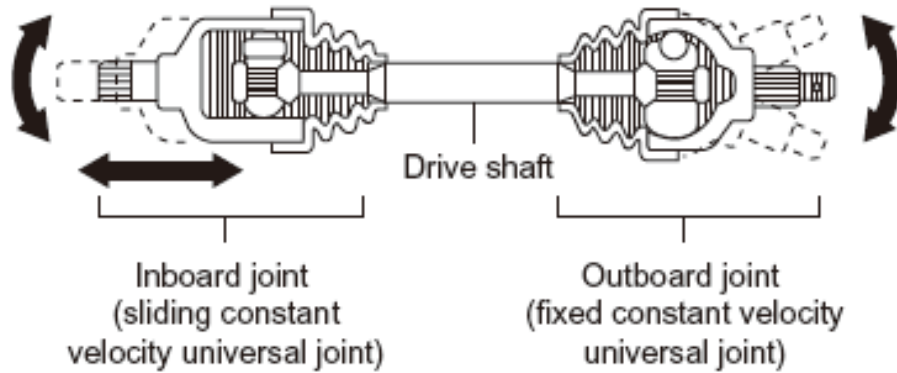

Figure 2: Drive shafts structure

## 1.2.2 Constant velocity universal joint

A constant velocity universal joint is used on the drive shaft in areas that transmit power with a large angle, such as a front-wheel drive vehicle and rear axle shaft in a rear-wheel drive independent suspension vehicle. The structure of a constant velocity universal joint is complex, but is designed so that no rotation speed changes occur in the driving axle and driven axle. This means there are no variations in the rotation speed and torque of the driving axle and driven axle, enabling smooth power transmission.

### 1.2.2.1 Bar field joint

3067

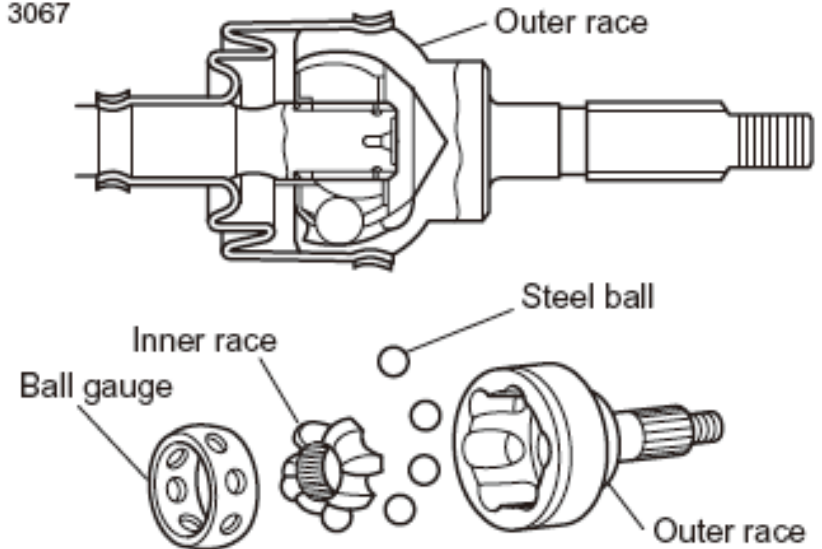

Figure 3: Bar field joint structure

The bar field joint components include an inner race and outer race that have guide grooves, and steel balls inside these guide grooves and a ball gauge that holds these balls.

When the 2 axles rotate while at an angle to each other, the spherical surfaces of the outer race and inner race change the angle while sliding in the groove direction. The steel balls sandwiched between the races transmit the power while rolling inside the guide grooves. This mechanism that absorbs the changes in angle maintains the same rotation speed for the driving axle and driven axle.

This means that the power is transmitted smoothly without any variations in the rotation speed and torque of the driven axle.

### 1.2.2.2 Tripod joint

The tripod joint components include a housing, roller and spider. Its power transmission is the same as that of the bar field joint, but also, because it absorbs the extension and contraction of the drive shaft caused by the up and down movement of the wheels, the roller can move along the housing groove in the axial direction.

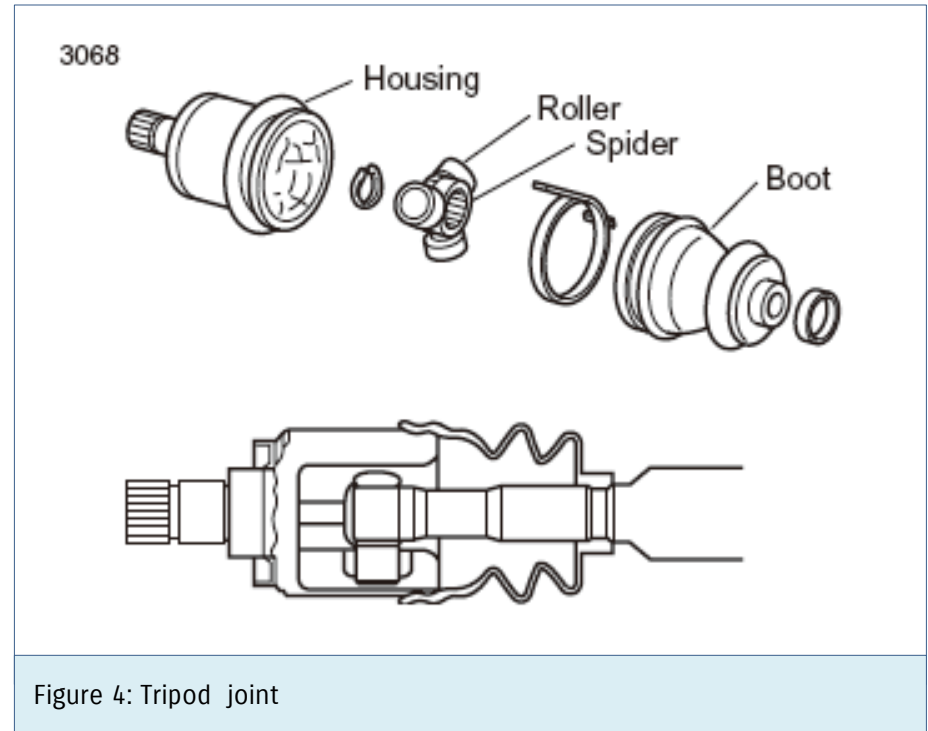
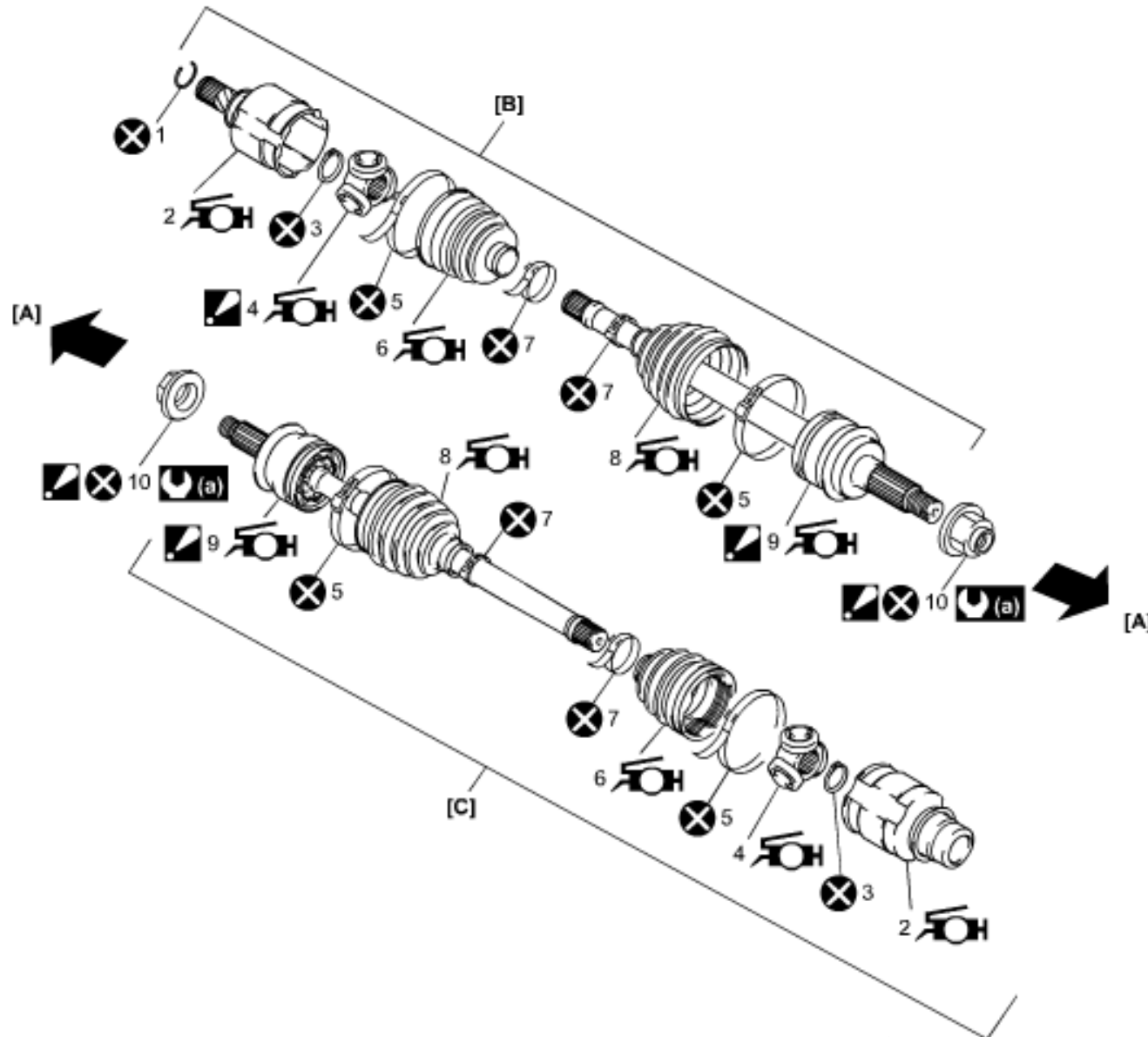

Figure 4: Tripod joint

## 1.2.3 Driveshaft components

NB: Suzuki Swift (AZH414) driveshaft shown



- [A] Wheel side
- [B] Left side
- [C] Right side
- [1] Circlip
- [2] Differential side (or intermediate shaft side) joint housing
- [3] Snap ring
- [4] Tripod joint
- [5] Boot band (big)
- [6] Differential side (or intermediate shaft side) boot
- [7] Boot band (Small)
- [8] Wheel side boot
- [9] Wheel side joint assembly
- [10] Drive shaft nut
- [11] Drive intermediate shaft
- [12] Intermediate support bolt
- [13]



## 1.3 Checks and maintenance

### 1.3.1 Drive shaft

Be careful of the following when disassembling the drive shaft.

- Draw reference marks on the parts.
- Before removing the boot, wrap the end of the drive shaft with tape to protect it from damage.

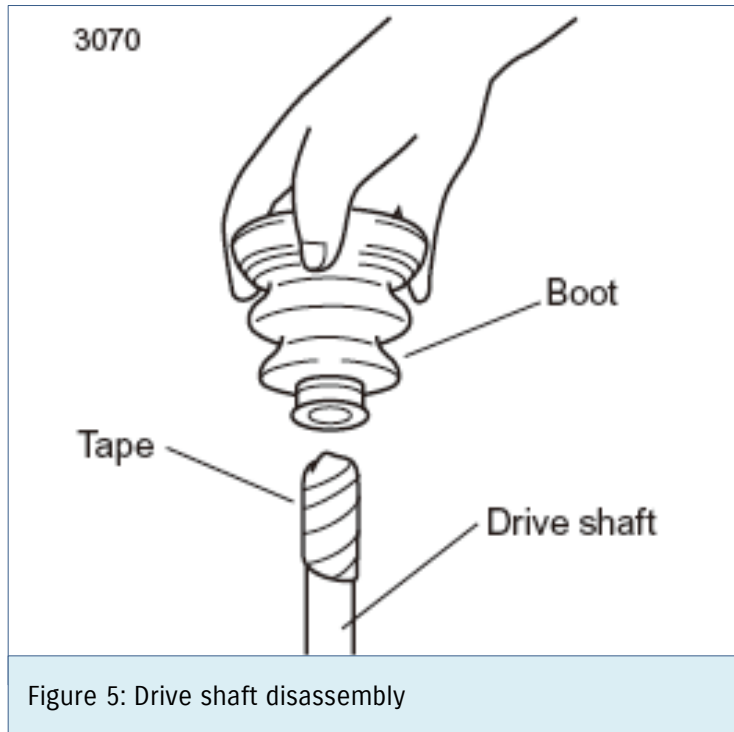

Assemble the boot band for the resin boot as shown in the figure relative to the rotation direction of the drive shaft when going forward. Properly mesh the protrusions with the grooves (3 locations).

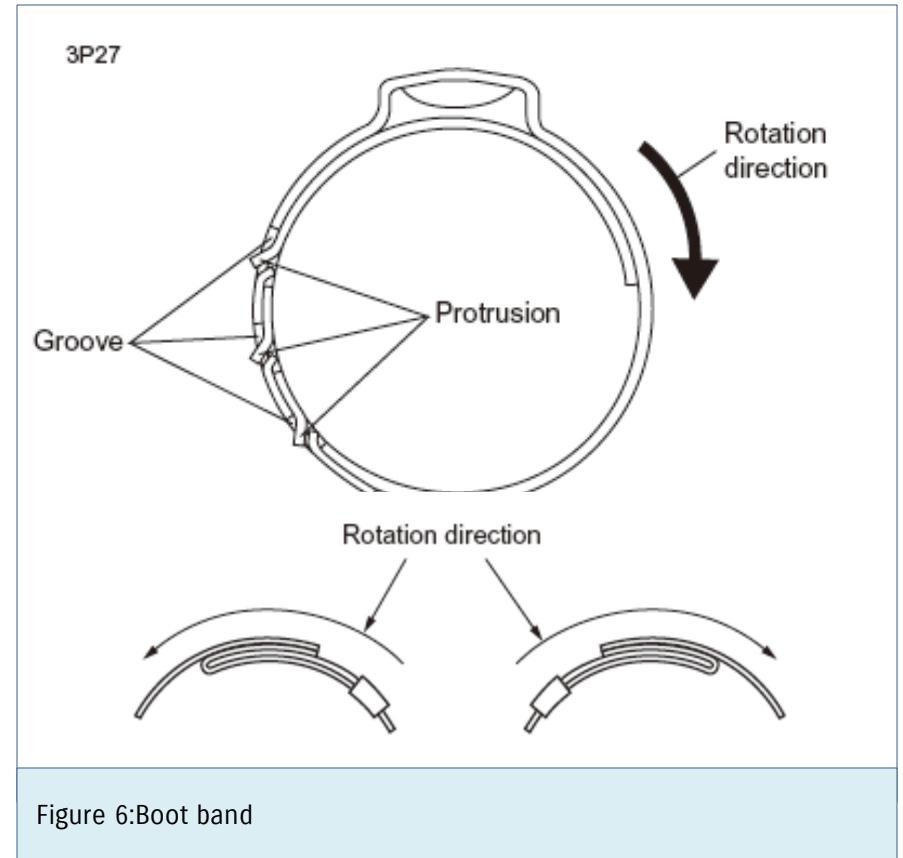

- Assemble the boot band for the rubber boot as shown in the figure relative to the rotation direction of the drive shaft when going forward.

When filling the boot with grease, be sure to fill to the specified level. If the specified level is exceeded it will cause grease leaks, while if the level is insufficient, the joint may seize.

Open the bellows-shaped area of the boot and check all around it that there are no cracks. Replace the boot if it is torn, but if there is abnormal noise, replace the boot by replacing the drive shaft assembly.

### 1.3.2 Constant velocity universal joint

Move the joint up and down and to the left and right, and check that the operation is smooth and that there is no significant rattling. Check that the parts that move in the axial direction do not catch and operate smoothly.

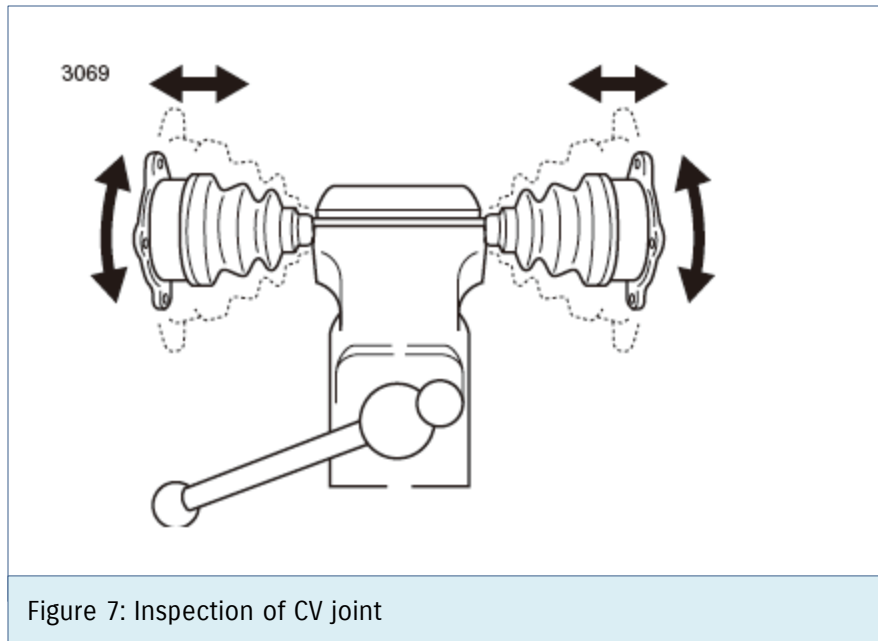

# Lesson 2:

## Propeller shaft

### Objectives

- Describe the function of the propeller shaft.
- Describe the function of the U-joints on the propeller shaft.
- Identify and name the different components/parts of the propeller shaft.
- Describe the function of the centre bearing.
- Describe the procedures to check the propeller shaft for bending.

## 2.1 Function

A propeller shaft transmits power from the transmission to the front or rear axle. It is used in FR vehicles and 4WD vehicles. Universal joints are installed on both ends of a propeller shaft or drive shaft. Even if the installation angle of the shaft changes, these joints make the shaft rotate smoothly for power transmission.

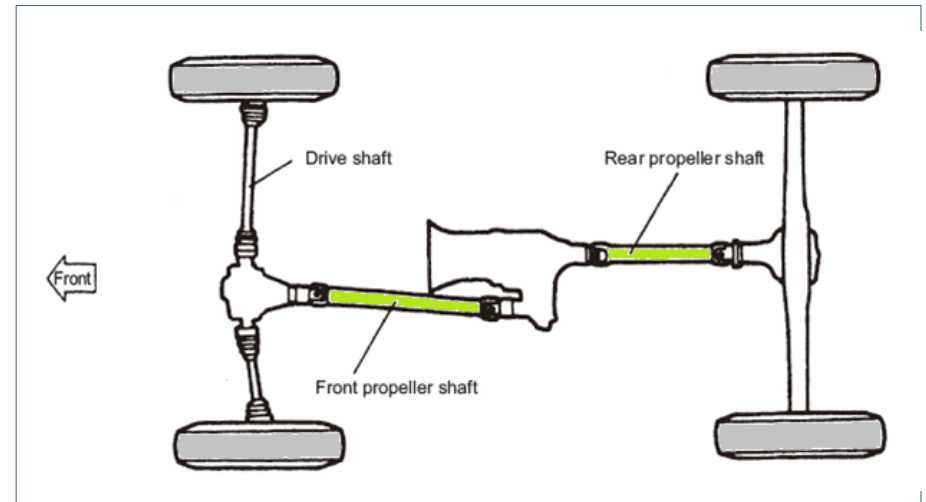
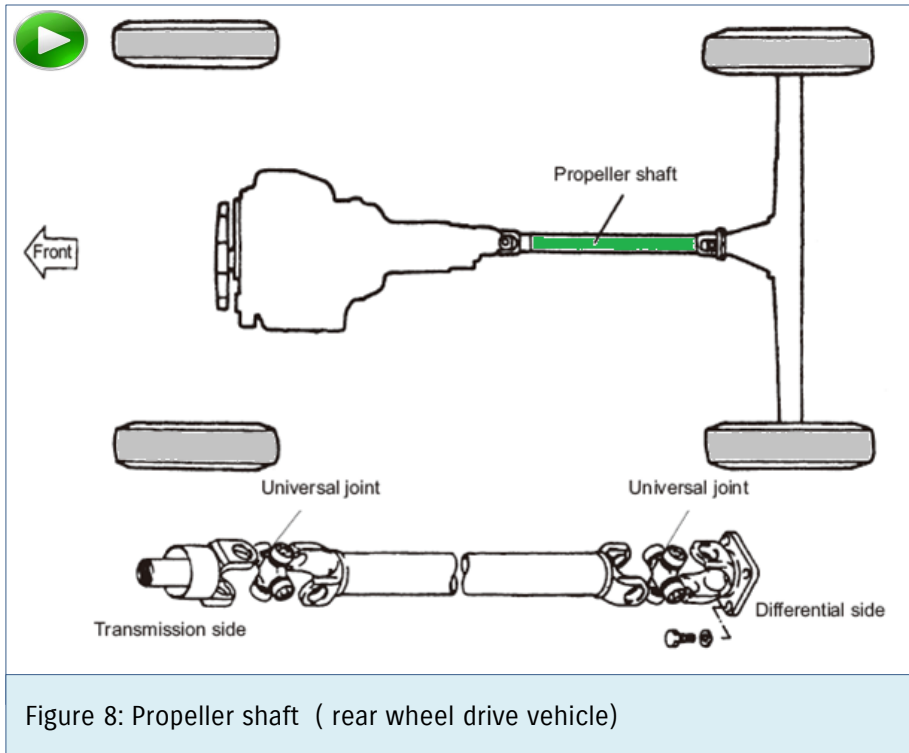

Figure 9: Propeller shafts (4WD vehicles)

## 2.2 Structure and operation

### 2.2.1 Propeller shaft



To transmit the powerful force from the engine, the propeller shaft is made from a steel pipe that is lightweight with high twisting strength and bending rigidity, and which has excellent properties for high speed rotation. The installation position of the propeller shaft that connects the transmission and the differential is not level, but is rather at a certain angle.

When driving on bumpy roads, the installation position changes through various different directions. In accordance with these angle and installation position changes, the propeller shaft extends, contracts and tilts.

This makes the rotation smooth and transmits the power to the final gear.

The figure below shows the components of the propeller shaft. They include the universal joints that respond to the angle changes, and the sleeve yoke and propeller shaft unit that respond to changes in length in the axial direction. On this shaft, balance pieces are installed at the time of production to balance the shaft for rotation (prevent vibration and abnormal noise).

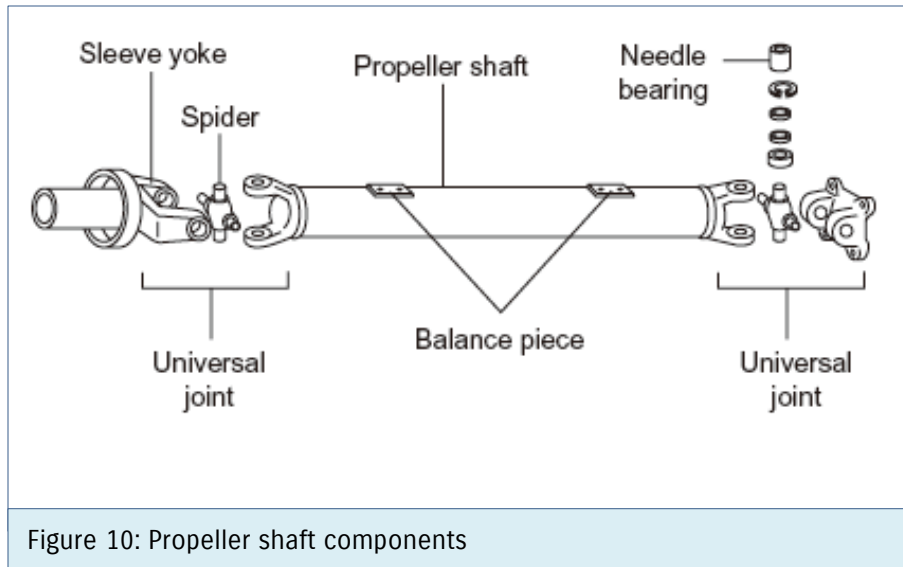

## 2.2.2 Center bearing

In high-performance vehicles or large vehicles where there is a long distance from the transmission to the driving axle, the propeller shaft is split into 2 or 3 shafts to raise its critical rotation speed. An area near the rear end of each shaft is supported with a radial ball bearing.

This bearing is called the center bearing, and it is installed via a rubber bush to prevent the transmission of vibration to the vehicle body during rotation.

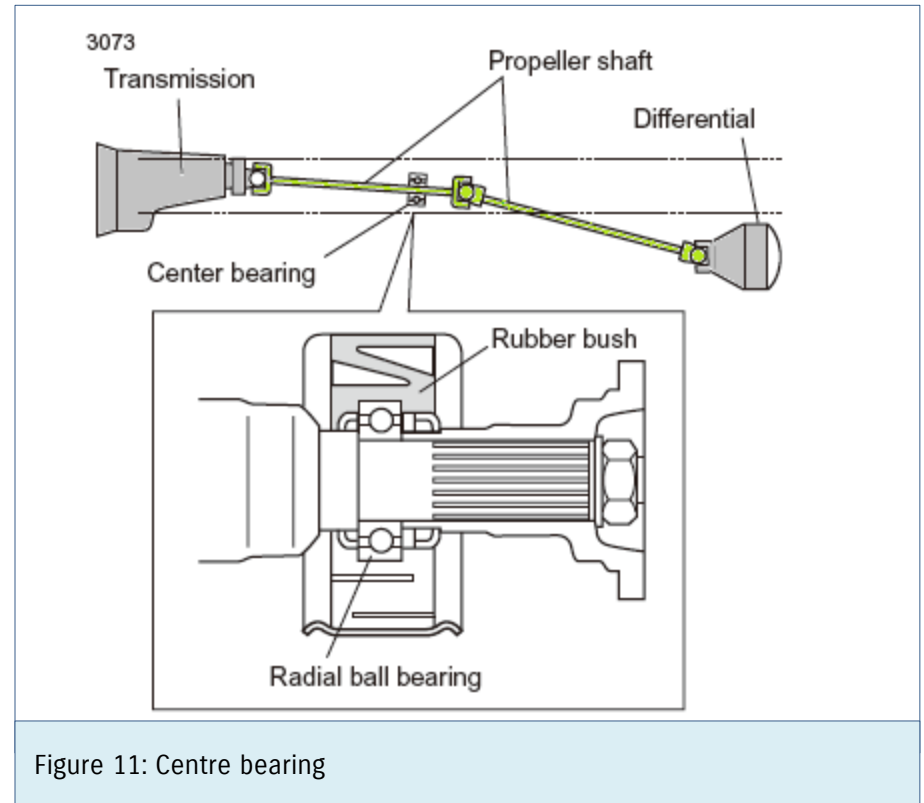

## Key Points

### Critical rotation speed

Because the propeller shaft rotates at a high speed while receiving ever-changing engine torque, twisting vibration is easily generated.

Also, the propeller shaft may bend, and if the weight is not balanced, then bending vibration may occur. If these vibrations and the natural frequencies of the propeller shaft match, it will damage the propeller shaft. This rotation speed is called the critical rotation speed.

The longer the shaft length, the lower the critical rotation speed.

## 2.2.3 Universal joint

A hook joint is often used as the universal joint. A hook joint's components include 2 yokes (input side and output side), a spider (cross-shaped axle) that connects these yokes, and a needle roller bearing.

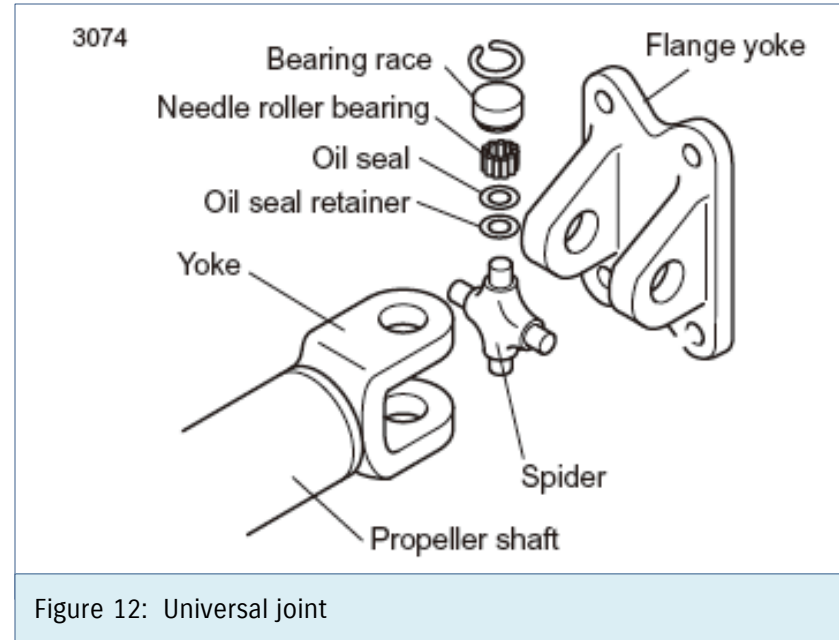

Figure 12: Universal joint

The universal joint's advantages is that its structure is simple and wearing is low. The disadvantage is that when the driving axle and driven axle rotate at a certain angle to each other, the driven axle's rotation speed and the torque vary relative to the driving axle.

To absorb these variations, the direction (phase) of the yokes that are connected to the universal joint are made the same.

This counteracts the rotation speed variations that are generated in the propeller shaft, achieving smooth power transmission. However, if the angle of the driven axle relative to the driving axle becomes too large, even when the direction of the yokes that are connected to the universal joint are made the same, the rotation speed variations cannot be counteracted.

For this reason, a universal joint is only used for parts such as the propeller shaft that have relatively small angle variations.

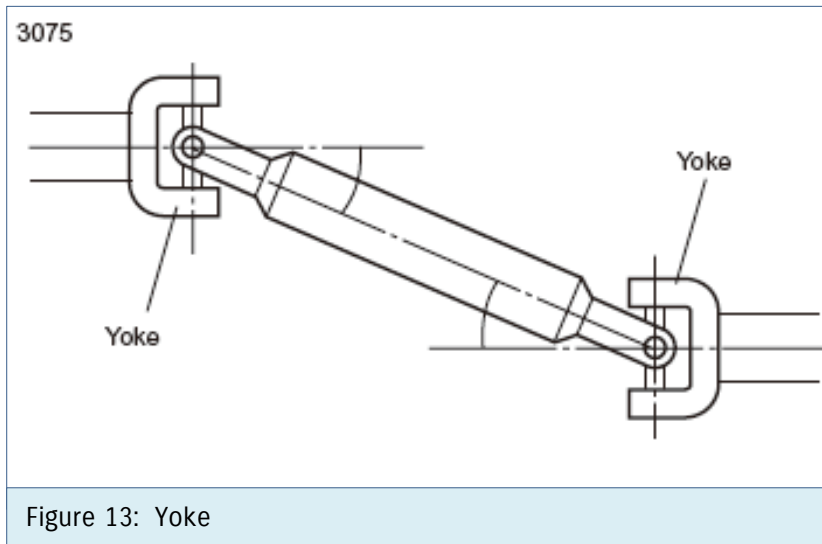

## 2.3 Checks and maintenance

### 2.3.1 Propeller shaft check

Check the bending of the propeller shaft if it was subjected to an impact, such as in an accident. Check the bending by placing the propeller shaft on a V block and setting a dial gauge on its center. Gently rotate the shaft and measure.

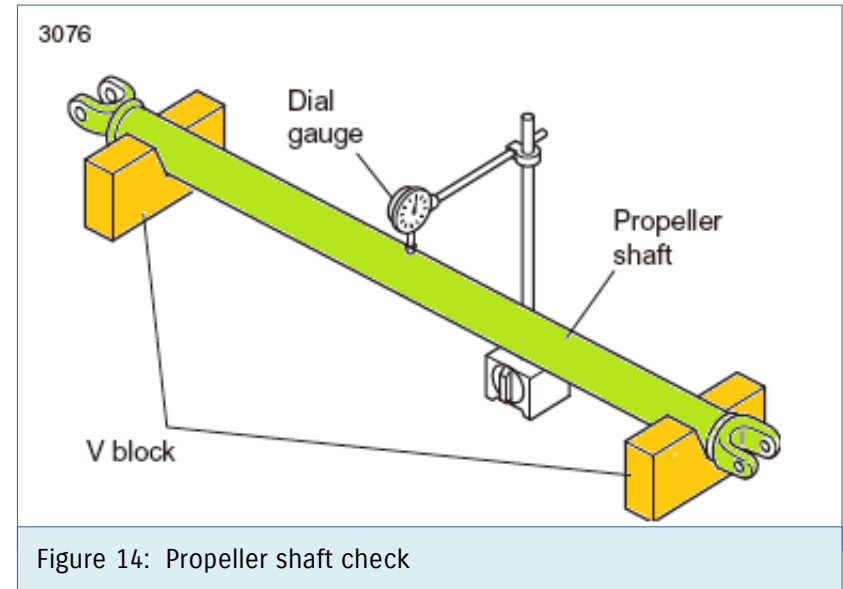

The bend amount is half the dial gauge reading (deflection). Before performing the measurement, remove the shaft paint from the areas that will contact the V block and the dial gauge. If the bend exceeds the specified value, replace the propeller shaft.

### 2.3.2 Universal joint check

If the propeller shaft rattles, check for joint wear. If there are any problems, replace the propeller shaft by replacing the assembly. The rattling rhythm of the abnormal noise from the propeller shaft is proportionate to the driving speed. It tends to be particularly loud when starting off from a stop and during deceleration (when the engine brake effect is transmitted to the drive system).

### 2.3.3 Important points for propeller shaft disassembly (Jimny:SN413)

1. Before removing the propeller shaft, draw reference marks on the joint and flange. This will make sure that you assemble the parts in the same position and maintain their balance.

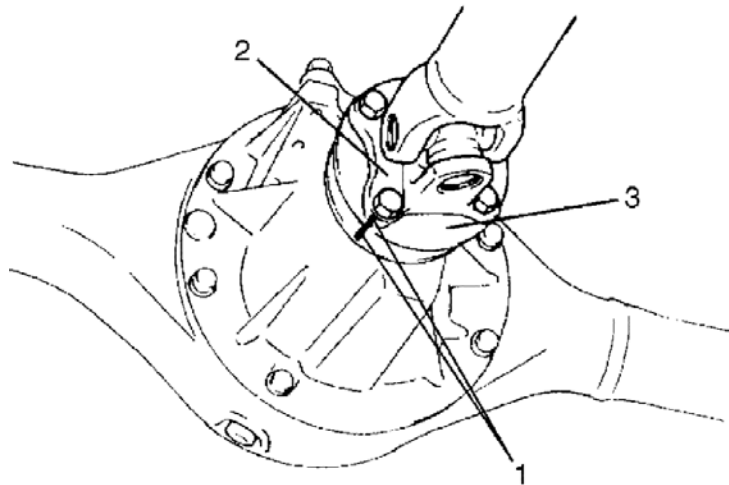

2. Use a special tool to push out the universal joint about 3 to 4 mm (a) from the flange yoke. Before pushing out the joint, apply a permeable lubricant between the bearing race (1) and yoke race (2).

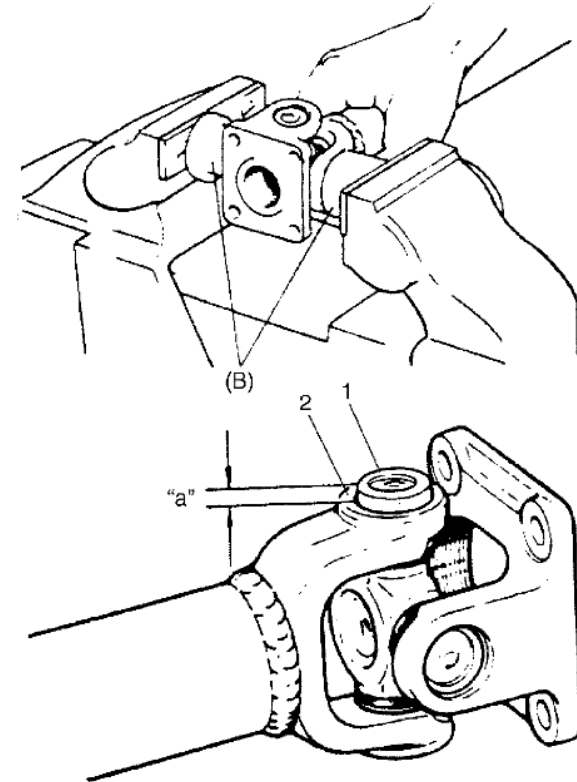

3



3. Hit the yoke with a plastic hammer to fully remove it from the bearing race.

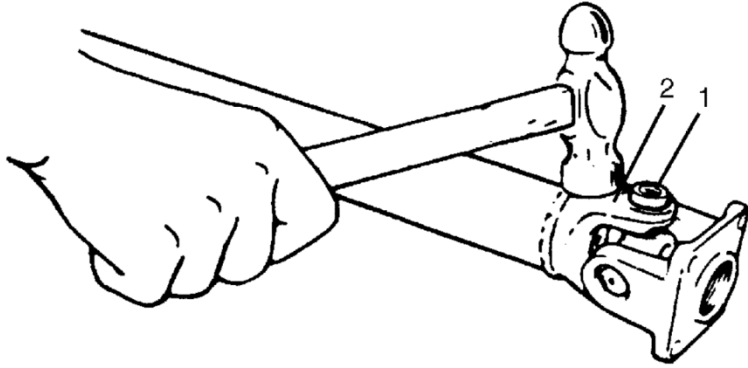

### 2.3.4 Important points for propeller shaft assembly (Jimny: SN413)

1. Be sure to apply grease to the spider bearing race, and check that the entire roller on the inner side of the spider bearing race is within the home position.



2. Always use a new snap ring, spider (1) and bearings (2) for assembly.

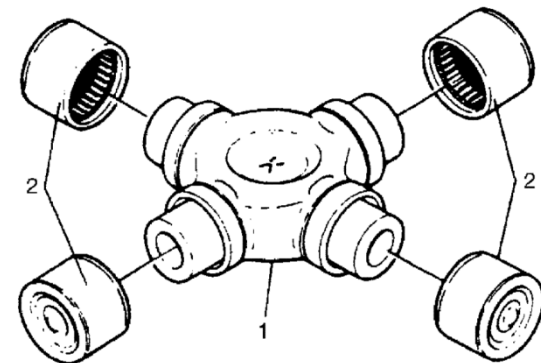

3. Insert the bearing race (2) on the yoke side (3), and hit the bearing race with a copper hammer (1) until it is in the same plane as the outer side of the yoke. Insert the spider (4) into the bearing race while making sure that the bearing race roller does not come apart. When hitting the bearing race, place a metal plate over the bearing race to prevent damage to the yoke.

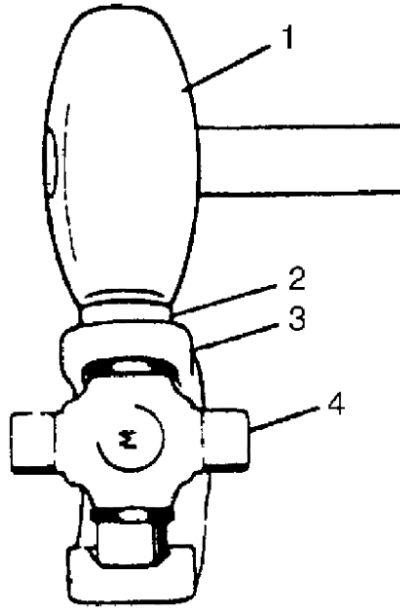

4. In the same way, insert the bearing race on the opposite side into the yoke, and hit the bearing race with a copper hammer until it is in the same plane as the outer side of the yoke.

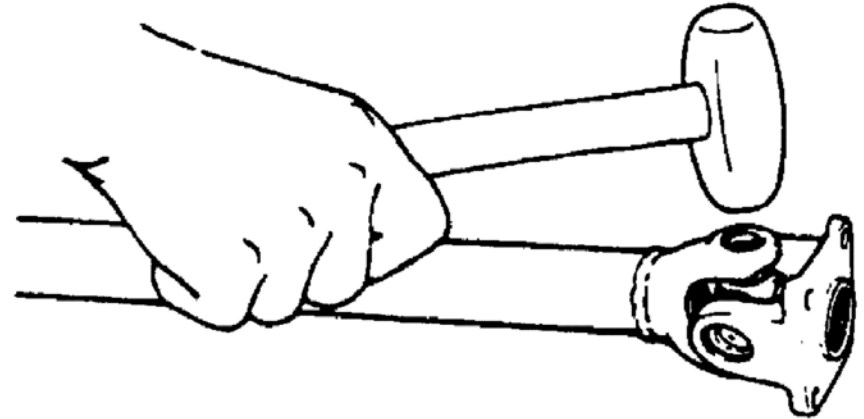

5. After assembly, check that both the shaft yoke and flange yoke move together smoothly.
6. Check that all the snap rings are properly inserted into the grooves.

# Lesson 3:

# Differential

## Objectives

At the end of this lesson, you will be able to:

- Describe the function of the differential
- Identify the different components/parts of the differential
- Explain the basic operating principle of the differential
- Describe the power flow in the differential during straight ahead travel
- Describe the power flow in the differential during cornering

### 3.1 Description

When a vehicle turns, each of the 4 tires follows a turning circle of a different size. If the left and right tires are connected directly with a single shaft, the tires on the inner side will slip. To prevent tire slip when turning, the outer tires must rotate more (more quickly) than the inner tires.

This problem is resolved by dividing the shaft into 2 parts and using a differential gear between them. The differential makes the tires rotate at different speeds, and through the final gear that is installed on the outer circumference of the differential case, reduces the rotation speed from the transmission and increases the torque.

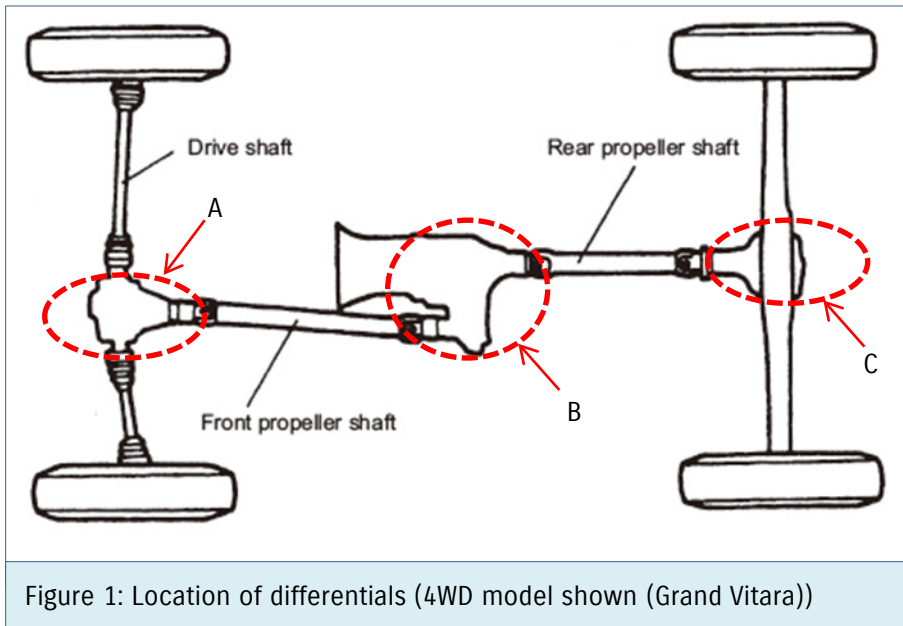

Figure 1: Location of differentials (4WD model shown (Grand Vitara))

- [A] Front differential
- [B] Centre differential
- [C] Rear differential

### 3.2 Rear differential construction

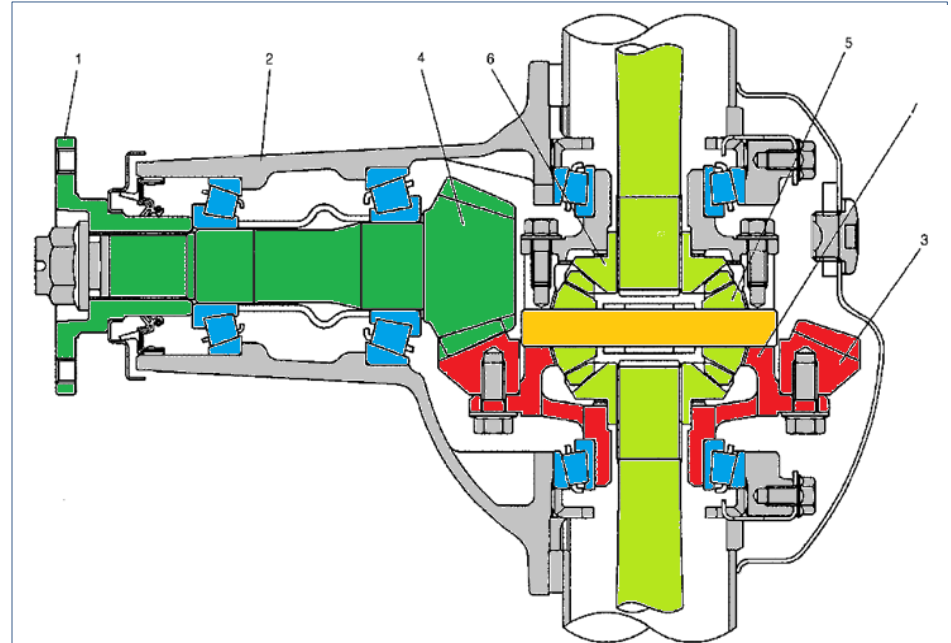

Figure 2: Rear differential construction (Suzuki Jimny SN413)

- [1] Companion flange
- [2] Differential carrier
- [3] Drive bevel gear
- [4] Drive bevel pinion
- [5] Differential pinion
- [6] Differential side gear
- [7] Differential case

The differential assembly using a hypoid bevel pinion and gear. The differential assembly is decisive in that the drive power is concentrated there. Therefore, use of genuine parts and specified torque is compulsory. Further, because of sliding tooth meshing with high pressure between bevel pinion and gear, it is mandatory to lubricate them by hypoid gear oil.

The hypoid gears have an advantage of preventing gear noise, at the same time, they require accurate adjustment of tooth contact and backlash.

### 3.3 Front differential construction

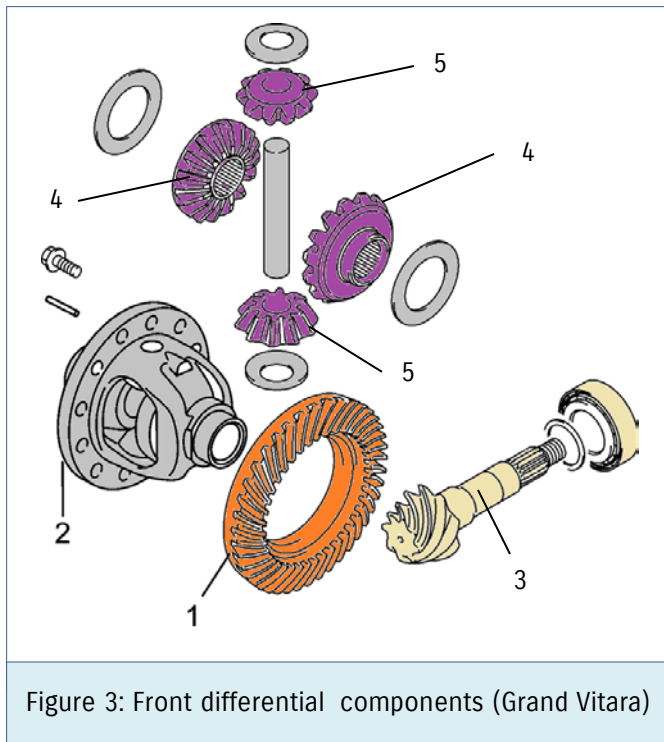

- [1] Bevel gear
- [3] Drive bevel pinion
- [5] Differential side gears

- [2] Differential case
- [4] Differential pinion

The front differential assembly for 4WD model uses a hypoid bevel pinion and gear. The differential assembly is decisive in that the drive power is concentrated there. Therefore, use of genuine parts and specified torque is compulsory. Further, because of sliding tooth meshing with high pressure between bevel pinion and gear, it is mandatory to lubricate them by hypoid gear oil.

The hypoid gears have an advantage of preventing gear noise, at the same time, they require accurate adjustment of tooth contact and backlash.

### 3.4 Structure and operation

#### 3.4.1. Differential (rear wheel drive vehicles and 4WD vehicles)

##### 3.4.1.1 Differential principle

In a basic differential construction, a differential pinion is assembled to a pinion shaft inside a differential case. These parts mesh into a differential gear. The center of the differential gear is splined and these splines connect to the axle shaft, which is the driving axle. The differential case is integrated with the drive bevel gear.

This means that the torque is transmitted from the propeller shaft to the axle shaft via the following route: propeller shaft → drive bevel pinion → drive bevel gear → differential case → differential pinion → differential gear → axle shaft.

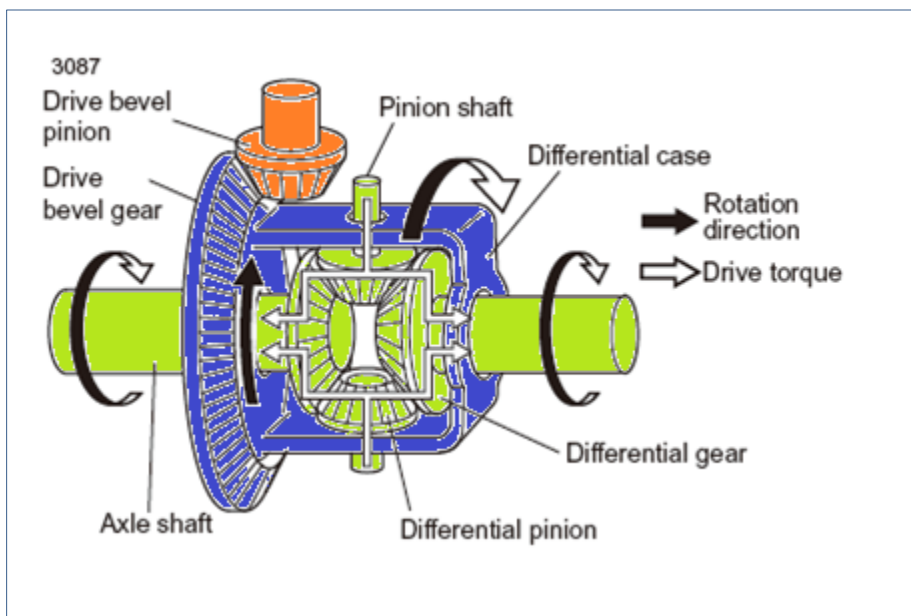

Figure 4: Differential

When going straight ahead, the rotation speeds of the left and right wheels are the same. The differential pinion that meshes with the differential gear does not rotate on the pinion shaft, but instead revolves unchanged together with the differential case so that the left and right wheels rotate at the same speed.

When turning, because the rotation speeds of the left and right wheels are different, the inner wheels of the turn are decelerated, while the outer wheels are accelerated. To do this, the differential pinion rotates around itself on the pinion shaft and revolves around the differential gear with the greater resistance, just enough for the appropriate rotation speed difference between the turning wheels. This drives the other differential gear to produce the differential effect.

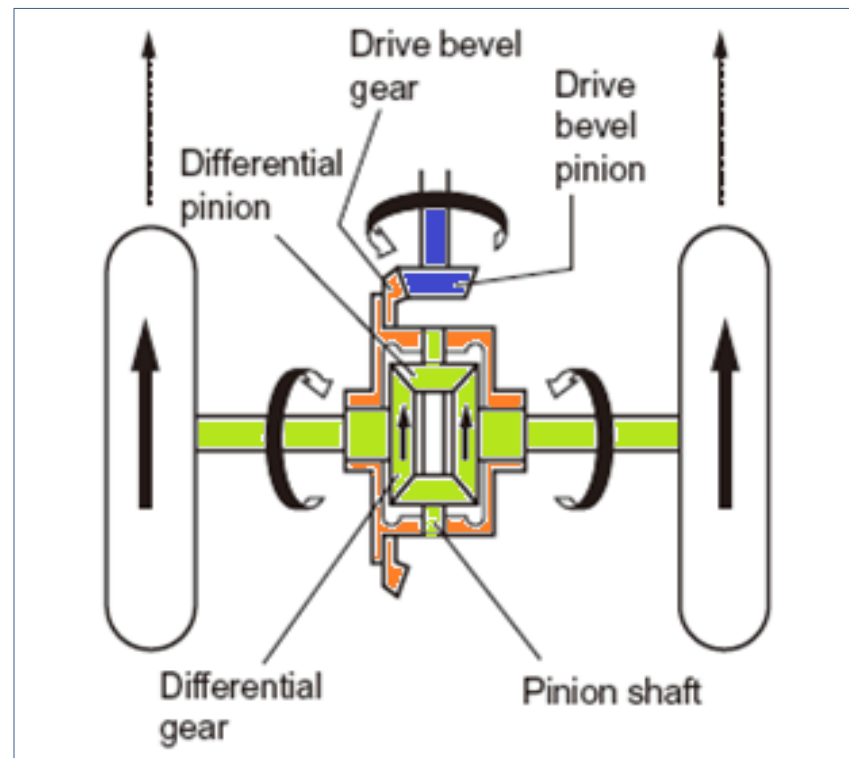

Figure 5: Straight ahead travel

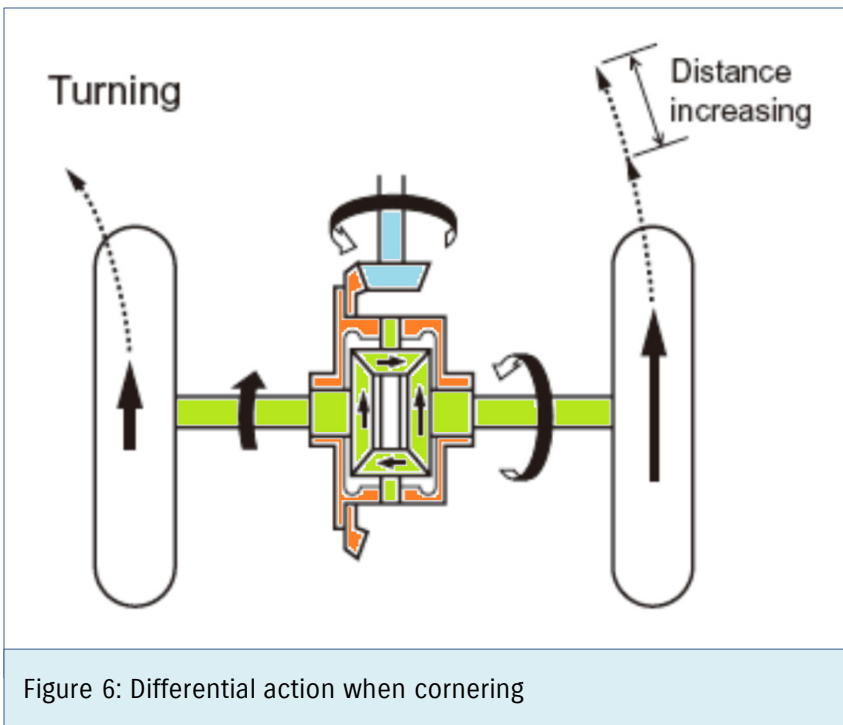

Figure 6: Differential action when cornering

For example, if the drive bevel gear rotates 500 times when driving straight ahead, the left and right wheels both rotate 500 times. But if the left wheel decelerates to 450 rotations when turning, the differential effect adds the difference of 50 rotations to the right wheel so that it rotates 550 times. In this way, if the drive bevel gear rotates 500 times, regardless of the changes between the left and right wheels, the total number of rotations for both wheels will always be 1,000.

The differential also transmits equal torque to the left and right wheels. As such, if the left axis goes over a slippery ice surface or enters mud, the friction with the road surface drops, and the left wheels slip and lose their power transmission.

Power transmission is also lost to the right wheels that do not spin, making it impossible to drive. The same phenomenon also occurs on bumpy roads when the drive wheels bounce and separate from the road surface, producing a rotation speed difference between the left and right axles. It occurs even after the wheels make contact with the road surface again.

The differential also transmits equal torque to the left and right wheels. As such, if the left axis goes over a slippery ice surface or enters mud, the friction with the road surface drops, and the left wheels slip and lose their power transmission. Power transmission is also lost to the right wheels that do not spin, making it impossible to drive.

The same phenomenon also occurs on bumpy roads when the drive wheels bounce and separate from the road surface, producing a rotation speed difference between the left and right axles. It occurs even after the wheels make contact with the road surface again.

#### 3.4.1.2 Final Gear

A spiral bevel gear or hypoid gear is used as the final gear in rear wheel drive vehicles. The final gear is made up of a drive bevel pinion and a drive bevel gear. The final gear and differential are integrated and positioned in the differential case.

The drive bevel pinion is positioned in the differential case and meshes to the drive bevel gear. The drive bevel gear is bolted to and integrated with the differential case. A differential is used so that adjustment for smooth driving is automatically performed when there is a rotation speed difference between the left and right wheels.

The differential case contains the final gear and the differential. In an independent suspension vehicle it is installed in a position such as the body, while in a rigid axle suspension vehicle, it is installed on the rear axle housing that covers the axle shaft that drives the rear wheels.

In front wheel drive vehicles, a transaxle is used that has an integrated structure that includes the transmission, final gear and differential.



Figure 7: Final gear drive



### 3.4.2 Differential (front wheel drive vehicles)

The differential principle is the same as in rear wheel drive vehicles. In general, a helical gear is used as the final gear of the transaxle. It is positioned in the transmission case together with the differential.

The gear ratio of the transmission multiplied by the final reduction ratio of the final gear is called the overall reduction ratio. The engine torque increases in proportion to this overall reduction ratio and the engine rotation speed decreases in inverse proportion to it

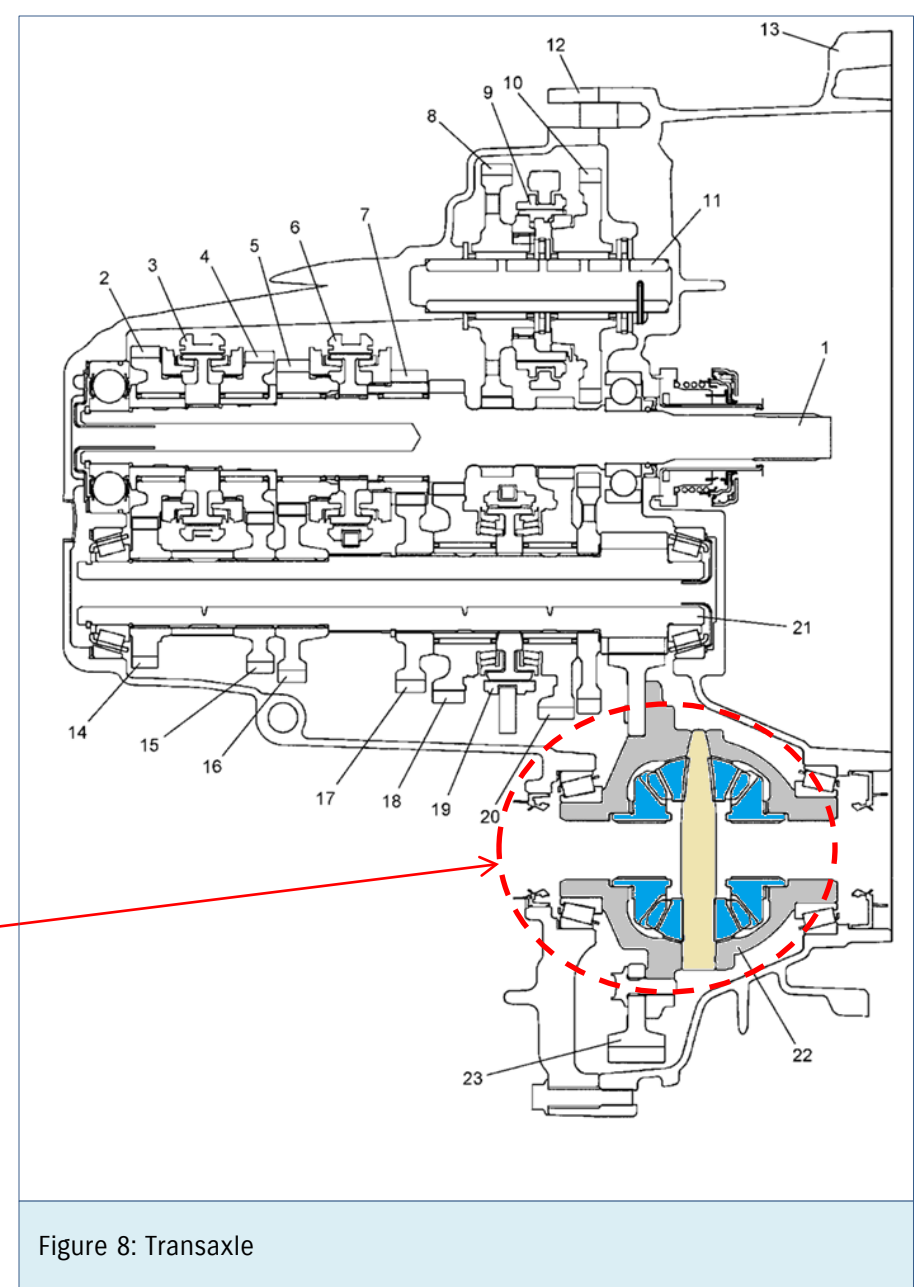
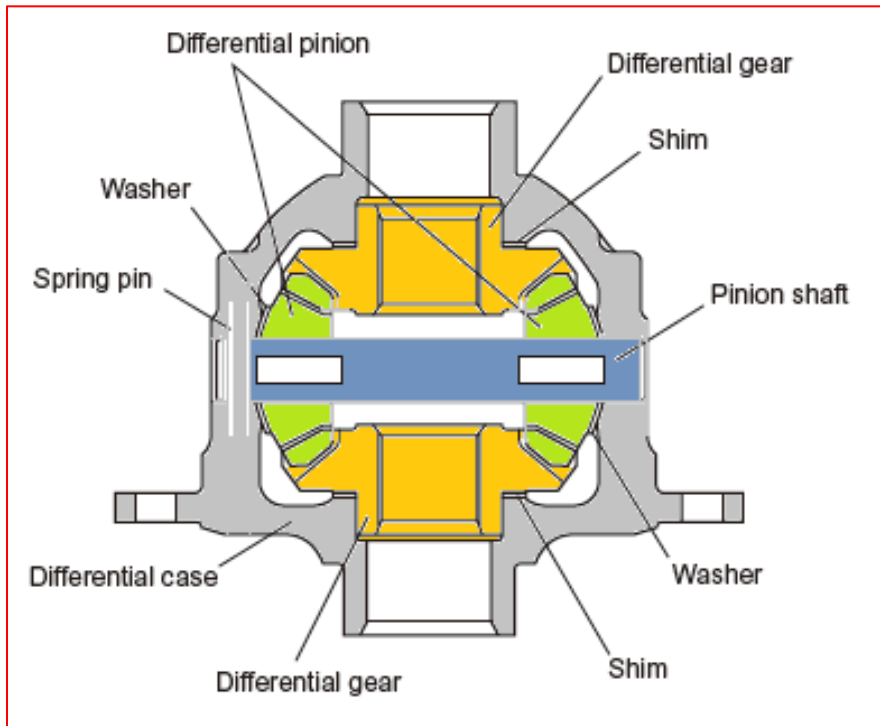

Figure 8: Transaxle

## Key Points

What is a helical gear?

A helical gear is a cylindrical gear with its teeth line in a helix shape. Although it looks like a spur gear with slanted teeth, it is more accurate to say that a helix teeth line on the outer circumference of the cylinder.

A helical gear has a better meshing efficiency than a spur gear, which makes it good in terms of strength and noise reduction.

### 3.5 Checks and maintenance

#### 3.5.1 Backlash check (*front wheel drive vehicle*)

Measure the allowance in the thrust direction of the differential gear. If it deviates from the standard range, select a shim and adjust. Refer to the service manual for specifications.

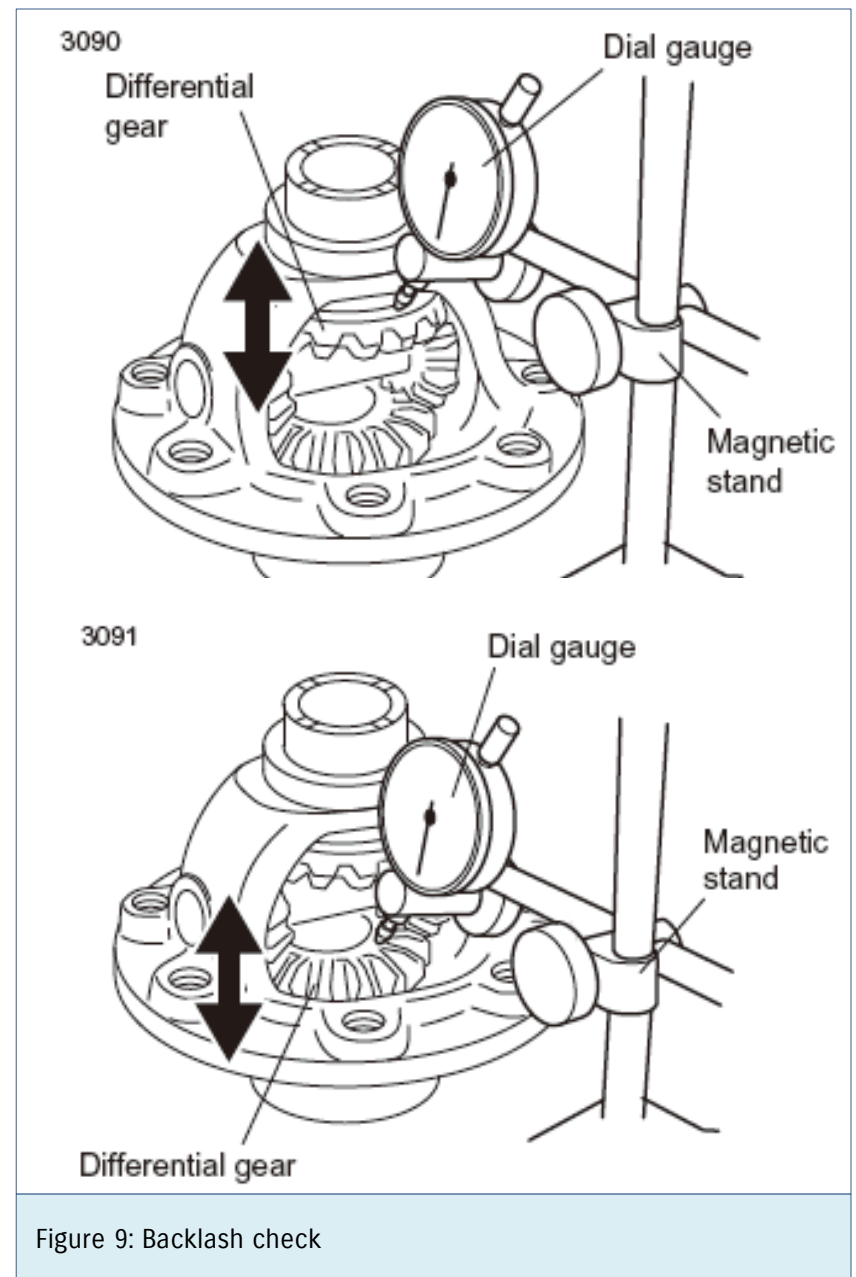

Figure 9: Backlash check

### 3.5.2 Teeth contact check

1. Clean the teeth surface of the bevel gear (about 10 teeth range (A)). Then use a brush (1) or sponge to evenly apply red lead primer to the teeth surface.
2. Rotate the gear to make the coated surface mesh with the bevel pinion. Rotate it to the front and rear with your hand to repeatedly mesh the surfaces.

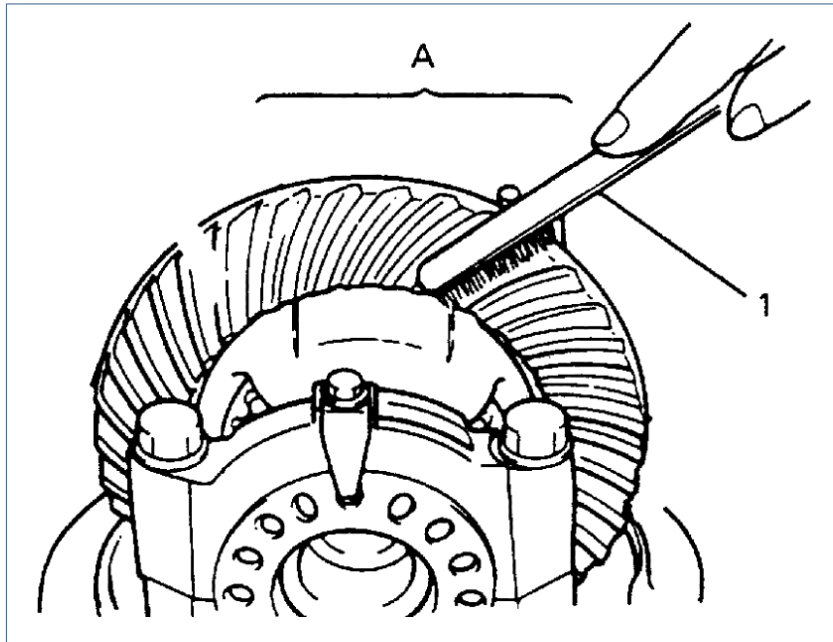

Figure 10: Teeth contact check

3. Check the teeth contact. If the teeth contact is abnormal, adjust again or replace as required.

4. If you correctly perform the shim adjustment for the bevel pinion and the backlash adjustment for the bevel gear, you should obtain a normal teeth contact.

But if the teeth contact is abnormal even after performing proper adjustment, there may be problems such as teeth wear or an abnormality in the differential case. Check the components and replace as required.

### Normal contact

Normal contact is contact with about 70% of a tooth's total length in the center.

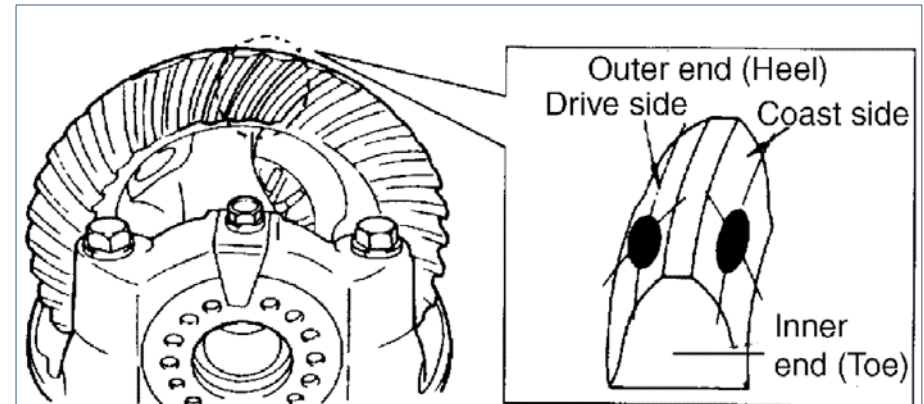

Figure 11: Normal contact

## High Contact

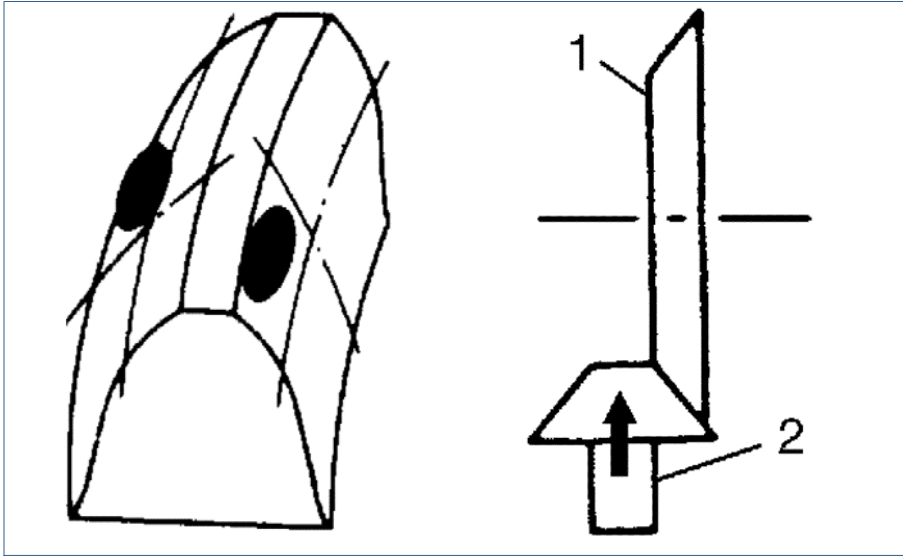

Figure 12: High contact

Pinion is positioned too far from the center of drive bevel gear (1)

- Increase thickness of pinion (2) height adjusting shim and position pinion closer to gear center.
- Adjust drive bevel gear backlash to specification.

## Low contact

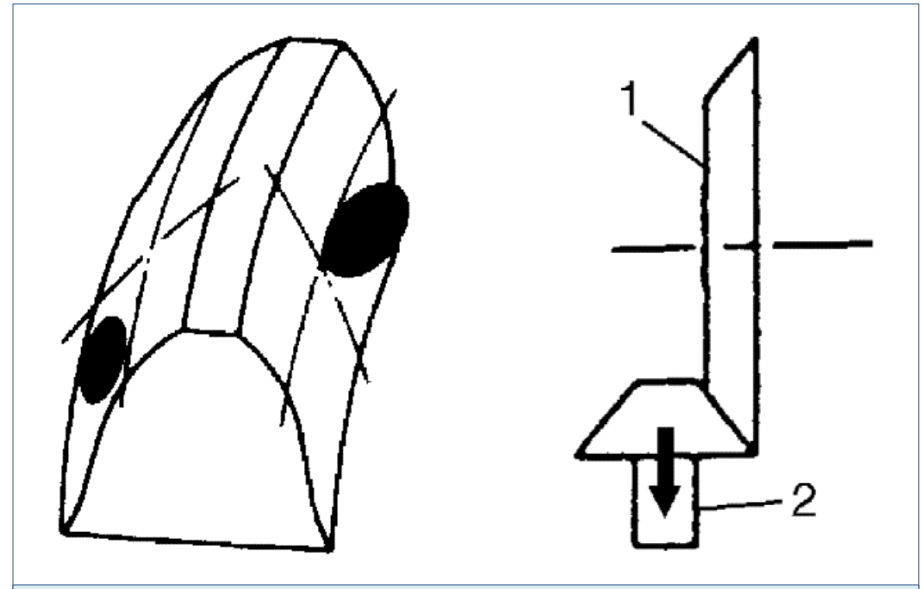

Figure 13: Low contact

Pinion is positioned too close to the center of driver bevel gear (1).

- Decrease thickness of pinion (2) height adjusting shim and position pinion farther from gear center.
- Adjust drive bevel gear backlash to specification.

## Toe or heel contact

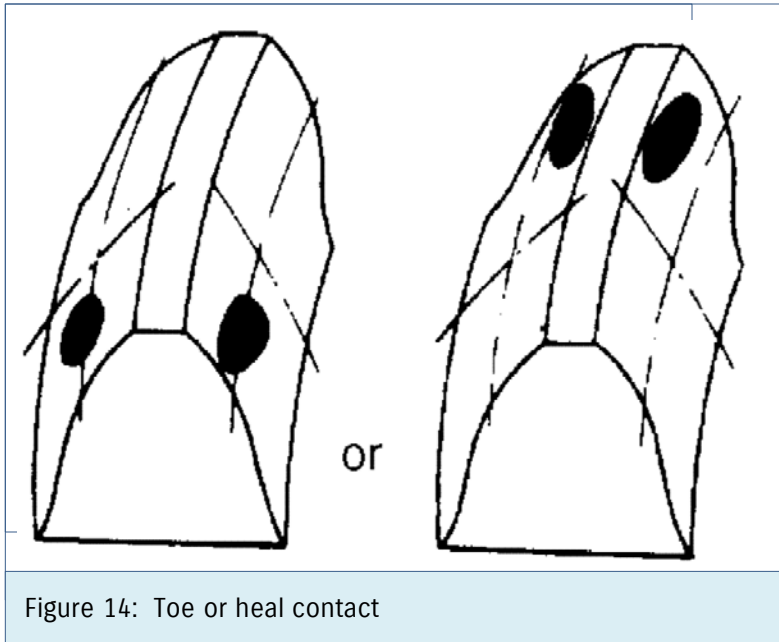

Figure 14: Toe or heel contact

These contact patterns, located on toe or heel on both drive and coast sides, mean that

- 1) both pinion and gear are defective,
- 2) carrier is not true and square, or
- 3) gear is not properly seated on differential case. The remedy is to replace the defective member.

These contact patterns indicate that the “offset” of differential carrier is too much or too little. The remedy is to replace the carrier with a new one.

## Other abnormal patterns

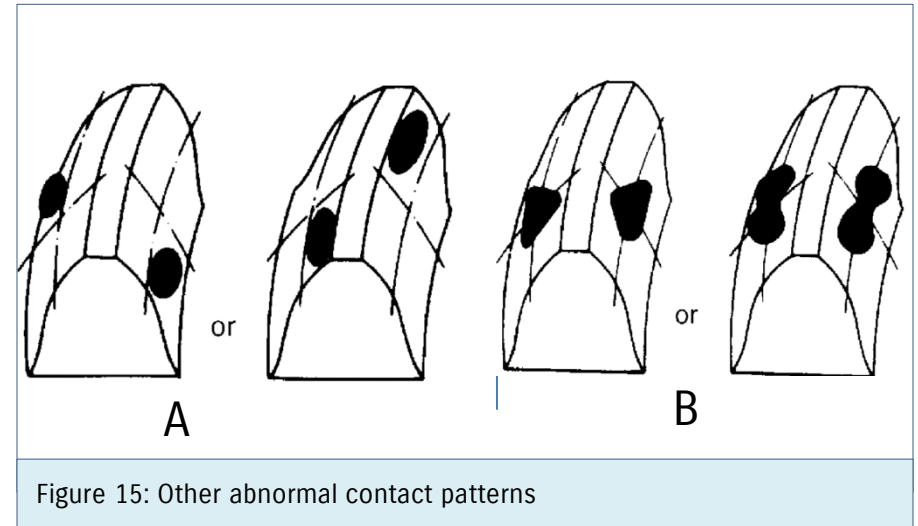

Figure 15: Other abnormal contact patterns

### Contact A

These contact patterns indicate that the “offset” of differential carrier is too much or too little. The remedy is to replace the carrier with a new one.

### Contact B

Irregular patterns: If the pattern is not oval, it means that bevel gear is defective. High or low spots on tooth surfaces or on the seat of bevel gear are the cause of irregular patterns appearing on some teeth.

The remedy is to replace the pinion and gear set and, if the seat is defective, so is differential case

### 3.5.3 Rear differential assembly (SN413)

To engage drive bevel pinion and gear correctly, it is pre-required to install drive bevel pinion to differential carrier properly by using adjusting shim. The following steps can be followed:

- 1) Select the bevel pinion shim
- 2) Adjust the bevel pinion preload
- 3) Adjust the allowance in the thrust direction of the differential gear
- 4) Adjust the bevel gear backlash

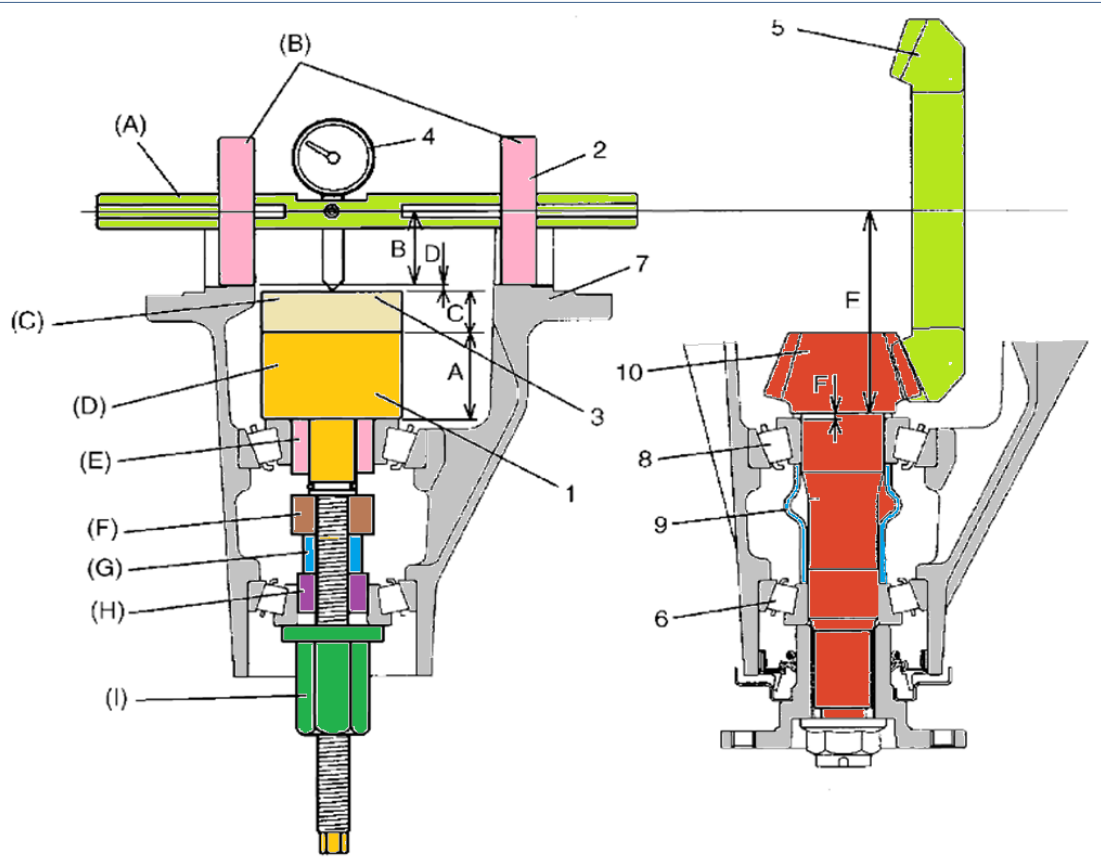

Figure 15: Installation of special tools for shim measurements

[A] Dummy height of pinion form dummy (=40mm)

[C] Block dummy thickness (14mm)

[D] Measured dimension

[F] Shim thickness for mounting distance adjustment (=D)

[2] Bearing form dummy with dummy shaft

[4] Dial gauge

[6] Front bearing

[8] Rear bearing

[10] Drive bevel pinion

[B] Radius of bearing form dummy (=40mm)

[A+B+C] Mounting distance adjusting dummy total size (=94mm)

[E] Drive bevel pinion mounting distance (=94mm)

[1] Pinion form dummy

[3] Block dummy

[5] Drive bevel gear

[7] Differential carrier

[9] Spacer

### 3.5.3.1 Select the bevel pinion shim

- 1) Assemble bearing form dummy with dummy shaft using special tools.
- 2) Install dial gauge (1) to bearing form dummy with dummy shaft as shown in the figure.

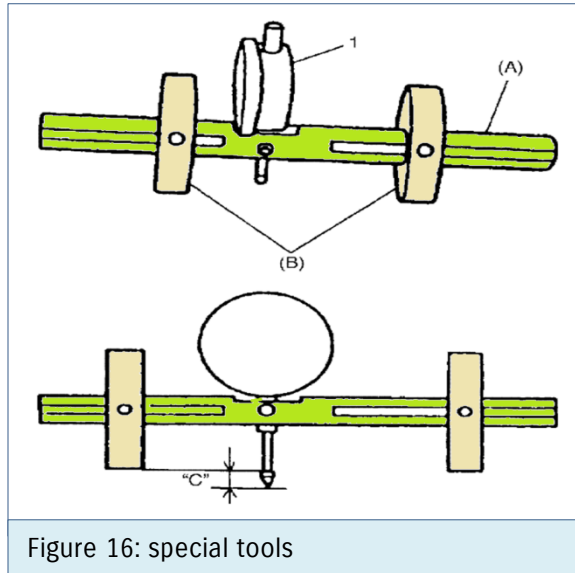

- [A] Dummy shaft
- [B] Dummy bearings
- [C] Dial gauge rod tip set distance (2-3mm)

Figure 16: special tools

- 3) Apply differential oil to drive bevel pinion front and rear bearings.
- 4) Install pinion form dummy (1), the other special tools and drive bevel pinion bearings to differential carrier (2).

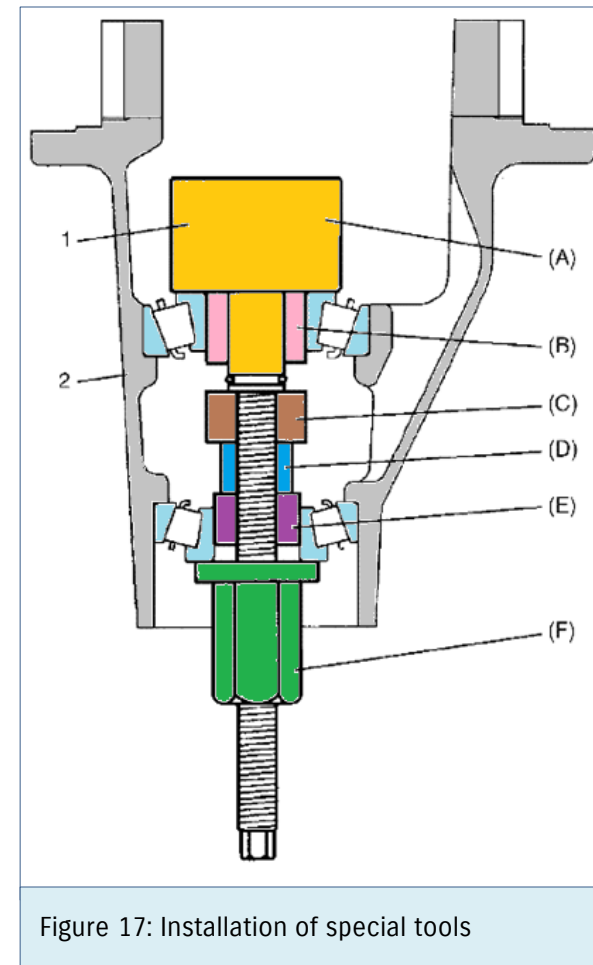
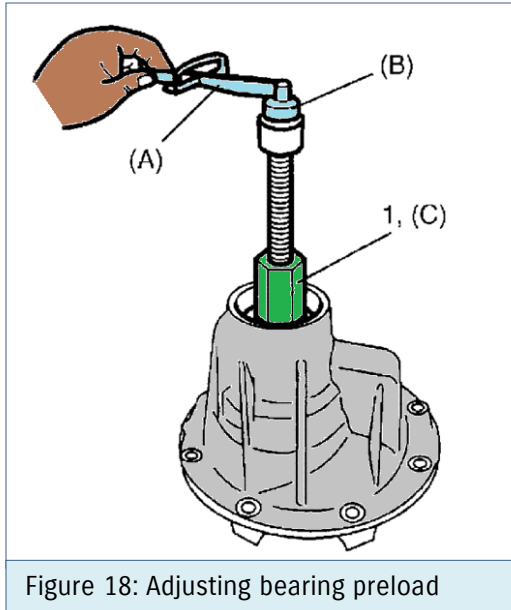

Figure 17: Installation of special tools

- [1] Pinion form dummy
- [2] Differential carrier
- [A] Bevel pinion shaft
- [B] Bevel pinion front collar
- [C] Bevel pinion rear collar
- [D] Bevel pinion rear collar
- [E] Bevel pinion rear collar
- [F] Bevel pinion nut

5) Tighten special tool (1) so that specified bearing preload is obtained.



[1] Bevel pinion nut  
[A] Torque wrench  
[B] Adapter

Figure 18: Adjusting bearing preload

6) Set dial gauge to bearing form dummy with dummy shaft and make 0 (zero) adjustment on surface plate.

**Note:**

- When setting dial gauge to bearing form dummy with dummy shaft, tighten screw lightly. Be careful not to over-tighten it, which will cause damage to dial gauge.
- With dial gauge set, turn dummy back and forth by hand a couple of times and attain accurate 0 (zero) adjustment.
- It is desirable that short pointer indicates beyond 2 mm when long one is at 0 (zero).

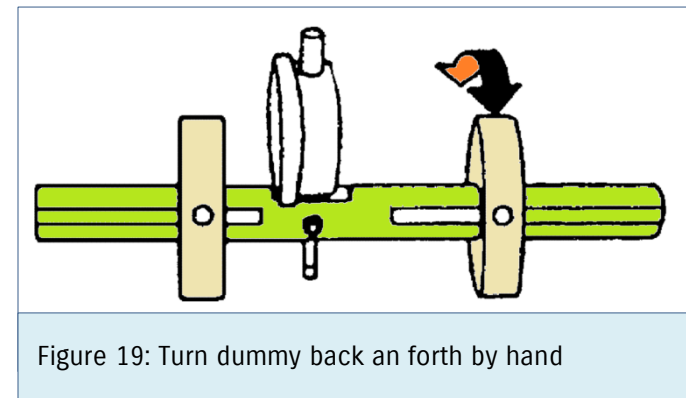

Figure 19: Turn dummy back and forth by hand

7) Put block dummy (3) on pinion form dummy (2).

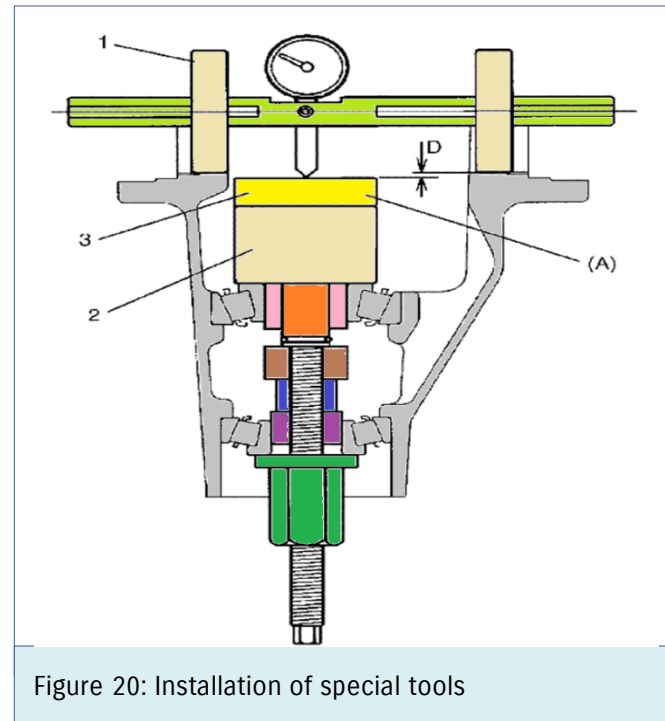

Figure 20: Installation of special tools



8) Place zero-adjusted bearing form dummy with dummy shaft (1) and dial gauge set on block dummy (3) and take measurement between 0 (zero) position and extended dial gauge measuring tip.

9) Obtain adjusting shim thickness by using measured value by dial gauge in the following equation.

Necessary shim thickness = Dial gauge measured value D

10) Select adjusting shim(s) (2) closest to measured value.

**Note:** Refer to the service manual for available shim thicknesses.

11) Put shim(s) in place and press-fit drive bevel pinion rear bearing (1) to drive bevel pinion (3) by using special tools and hydraulic press

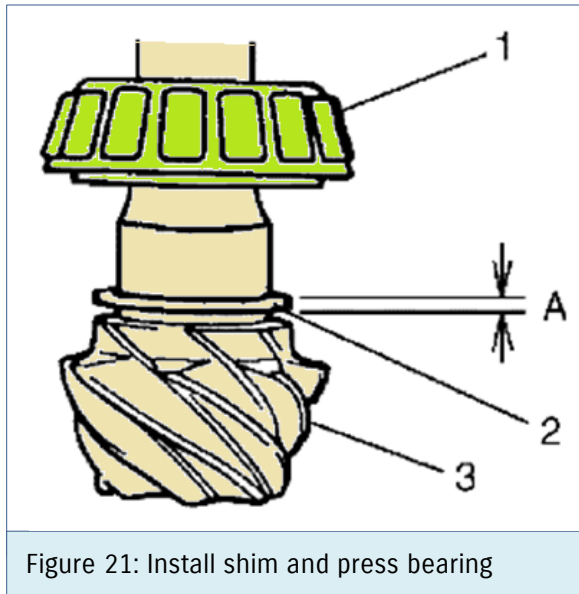

Figure 21: Install shim and press bearing

### 3.5.3.2 Adjust bevel gear backlash

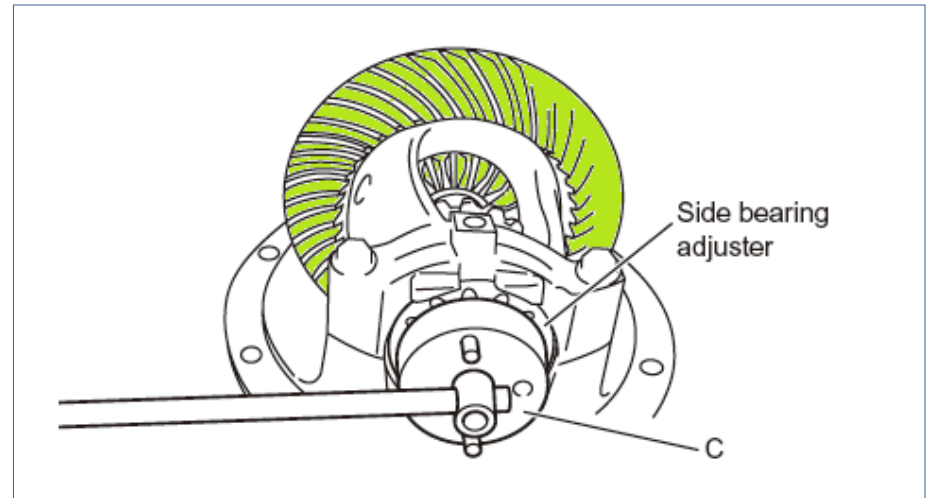

Figure 22: Adjusting bevel gear backlash [C] Side bearing wrench

- 1) Install the bevel gear on to the differential case, apply thread lock to the threads of the bolts and tighten them to the specified torque.
- 2) Use the special tool to press fit the 2 differential side bearing inner races to the differential case with the press.
- 3) Assemble the differential case together with the bevel gear and the 2 differential side bearings.
- 4) Install the 2 differential side bearing caps and provisionally tighten them with bolts.
- 5) Apply a small amount of oil to the bearing, and use the special tool to gently tighten the side bearing adjuster until the outer race makes full contact with the inner race.

### Caution:

- When the side bearing adjuster becomes heavy, do not tighten it any more.

6) Use the dial gauge to measure the backlash. If it deviates from the standard, rotate the side bearing adjusters on the left and right, and measure again.

Specifications: Refer to the service manual for backlash specifications.

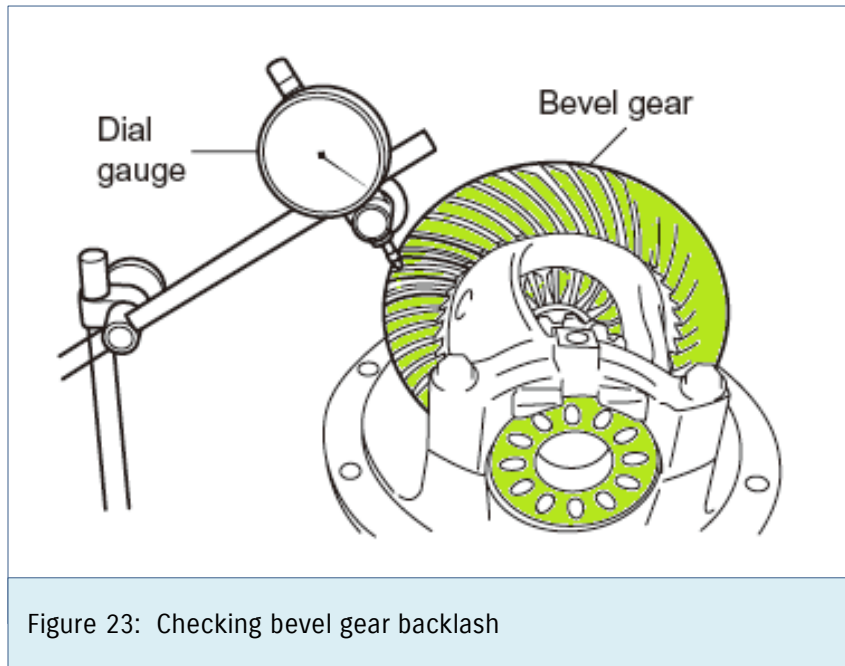

7) Measure the rotation torque of the flange nut. If it deviates from the standard, rotate the side bearing adjuster and repeat the procedure from step 6).

8) Tighten the bolt of the differential side bearing cap to the specified torque. Refer to the service manual for tightening torque specification.

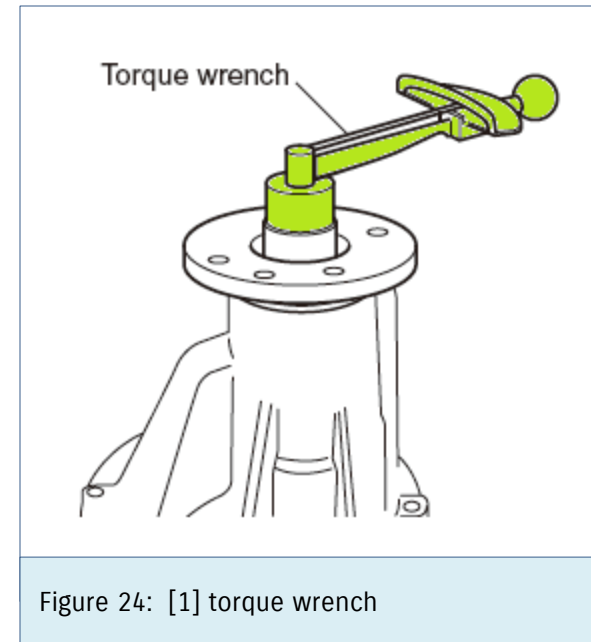

9) Assemble the 2 differential side bearing lock plates, and tighten the bolts to the specified torque.

### 3.5.4 Differential symptom diagnosis

Condition	Possible Cause
<b>Gear noise</b>	Deteriorated or water mixed lubricant
	Inadequate or insufficient lubricant
	Maladjusted backlash between drive bevel pinion and gear
	Improper tooth contact in the mesh between drive bevel pinion and gear
	Loose drive bevel gear securing bolts
	Damaged side gear(s) or side pinion(s)
<b>Bearing noise</b>	Constant noise: Deteriorated or water mixed lubricant
	Constant noise: Inadequate or insufficient lubricant
	Noise while coasting: Damaged bearing(s) of drive bevel pinion
	Noise while turning: Damaged differential side bearing(s) or axle bearing(s)
<b>Oil leakage</b>	Clogged breather plug
	Worn or damaged oil seal
	Excessive oil
	Loose differential carrier bolts

## Summary

- The driveshaft is used for power transmission between the differential and the wheels.
- CV joints are installed on drive shafts to enable power transmission in a different angles.
- The propeller shaft is used to transmit drive torque from the transmission (transfer case in 4WD vehicles) to the rear differential (rear wheel drive vehicles).
- A propeller shaft is also used to transmit drive torque from the transfer case to the front differential (4WD vehicles).
- The differential transfers torque through a 90° angle.
- The differential provides the final gear reduction.
- The differential allows the wheels to rotate at different speeds when the vehicle is cornering.

## Reference

The following abbreviations can be used in this training manual

### A

A/B	Air Bag
ABDC	After Bottom Dead Center
ABS	Anti-lock Brake System
AC	Alternating Current
A/C	Air Conditioning
A-ELR	Automatic-Emergency Locking Retractor
A/F	Air Fuel Ratio
ALR	Automatic Locking Retractor
API	American Petroleum Institute
APP	Accelerator Pedal Position
A/T	Automatic Transmission, Automatic Transaxle
ATDC	After Top Dead Center
ATF	Automatic Transmission Fluid, Automatic Transaxle Fluid
AWD	All Wheel Drive
API	American Petroleum Industry

### B

BARO	Barometric Pressure
BBDC	Before Bottom Dead Center
BCM	Body electrical Control Module
BTDC	Before Top Dead Center
B+	Battery Positive Voltage
BB+	Battery Positive Voltage for Backup

### C

CAN	Controller Area Network
CKP	Crankshaft Position
CMP	Camshaft Position
CO	Carbon Monoxide
CO2	Carbon Dioxide
CPP	Clutch Pedal Position
CPU	Central Processing Unit
CVT	Continuously Variable Transmission, Continuously Variable Transaxle

### D

DC	Direct Current
D/C	Driving Cycle
DLC	Data Link Connector
DOHC	Double Over Head Camshaft
DOJ	Double Offset Joint
DOT	Department of Transportation
DPF®	Diesel Particulate Filter
DRL	Daytime Running Light
DTC	Diagnostic Trouble Code (Diagnostic Code)
D/C	Driving Cycle

<b>E</b>	
EBD	Electronic Brake Force Distribution
ECM	Engine Control Module
ECT	Engine Coolant Temperature
ECU	Electronic Control Unit
EEPROM	Electrically Erasable Programmable Read Only Memory
EFE Heater	Early Fuel Evaporation Heater
EGR	Exhaust Gas Recirculation
EGT	Exhaust Gas Temperature
ELR	Emergency Locking Retractor
ENG A-Stop	Engine Auto Stop Start
EPS	Electronic Power Steering
ESP®	Electronic Stability Program
EVAP	Evaporative Emission

<b>G</b>	
GND	Ground
GPS	Global Positioning System
GL	Gear libricant

<b>H</b>	
HVAC	Heating, Ventilating and Air Conditioning
HC	Hydrocarbons
HFC	Hydro Fluorocarbon
HI	High
HO2S	Heated Oxygen Sensor

<b>I</b>	
IAC	Idle Air Control
IAT	Intake Air Temperature
IMT	Intake Manifold Tuning
ISC	Idle Speed Control
ISO	International Organization for Standardization

<b>J</b>	
JIS	Japanese Industrial Standards
J/B	Junction Block
J/C	Junction Connector

<b>L</b>	
L	Left
LCD	Liquid Crystal Display LED Light Emitting Diode
LHD	Left Hand Drive vehicle
LIN	Local Interconnect Network
LO	Low
LSPV	Load Sensing Proportioning Valve

<b>M</b>	
MAF	Mass Air Flow
MAP	Manifold Absolute Pressure
Max	Maximum
MFI	Multiport Fuel Injection
Min	Minimum
MIL	Malfunction Indicator Lamp (“CHECK ENGINE” Light or “SERVICE ENGINE SOON” Light)
M/T	Manual Transmission, Manual Transaxle

<b>N</b>	
NOx	Nitrogen Oxides
<b>O</b>	
OBD	On-Board Diagnostic system
OCM	Occupant Classification Module
OCV	Oil Control Valve
O/D	Overdrive
OHC	Over Head Camshaft
O2S	Oxygen Sensor
<b>P</b>	
PCM	Powertrain Control Module
PCV	Positive Crankcase Ventilation
PM	Particulate Mater
PNP	Park / Neutral Position
P/S	Power Steering
PSP	Power Steering Pressure
<b>R</b>	
R	Right
RAM	Random Access Memory
RHD	Right Hand Drive Vehicle
ROM	Read Only Memory
RPM	Engine Speed
<b>S</b>	
SAE	Society of Automotive Engineers
SDM	Sensing and Diagnostic Module (Air Bag Controller, Air bag Control Module)
SDT	Smart Diagnostic Tester
SFI	Sequential Multiport Fuel Injection
SI	System International
SOHC	Single Over Head Camshaft
SRS	Supplemental Restraint System

<b>T</b>	
TCC	Torque Converter Clutch
TCM	Transmission Control Module
TCSS	Traction Control Support System
TDC	Top Dead Center
TP	Throttle Position
TPMS	Tire Pressure Monitoring System
TWC	Three-Way Catalytic converter
<b>U</b>	
UART	Universal Asynchronous Receiver / Transmitter
USB	Universal Serial Bus
<b>V</b>	
VFD	Vacuum Fluorescent Display
VIN	Vehicle Identification Number
VSS	Vehicle Speed Sensor
VVT	Variable Valve Timing
<b>W</b>	
WU-OC	Warm Up Oxidation Catalytic converter
WU-TWC	Warm Up Three-Way Catalytic converter
<b>Other</b>	
2WD	2-Wheel Drive
4WD	4-Wheel Drive

Note: ESP is a trademark of Daimler AG  
DPF® is a trademark of HJS Fahrzeugtechnik GmbH & Co KG and Suzuki is the trade mark licensee.

Well done, you have now completed  
the “DS01 Driveshaft / axle” online  
training course!

Please take the online exam