

STARTING SYSTEM

ST

IN-VEHICLE INSPECTION	ST- 2
STARTER	ST- 2
STARTER RELAY	ST- 3
NEUTRAL START SWITCH	ST- 3
STARTING SYSTEM CIRCUIT	ST- 4
STARTER	ST- 5
COMPONENTS	ST- 5
UNIT CHECK OF STARTER	ST- 7
DISASSEMBLY	ST- 8
INSPECTION	ST-12
ASSEMBLY	ST-19
SPECIFICATIONS	ST-23
SSTs	ST-23
TIGHTENING TORQUE	ST-23

JST00001-00000

IN-VEHICLE INSPECTION

STARTER

1. Place the shift lever to the neutral position. Apply the parking brake lever.
2. Remove the EFI fuse provided inside the relay box so that the engine may not start.
3. Set the ignition switch to the ST position. Check to see if the engine cranks.
4. If the engine will not crank, check the battery for damage or charging state. Also, check the harness for continuity.
5. On the A/T vehicles, check the starter relay and neutral start switch.
6. If the engine still will not crank even after the checks above have been performed, remove the starter motor and perform the unit check.

JST00002-00000

WARNING:

- When removing the starter, firstly disconnect the negative terminal of the battery. Then, disconnect the positive terminals (+B, ST) at the starter side. Since the battery voltage is always applied to the starter +B terminal, failure to observe this removing sequence may lead to battery short, which is extremely dangerous.

CAUTION:

- If the starter terminals or connections between the battery terminals and the wires are loose, the connections may generate heat. Thus, loose terminals or connections are potentially-hazardous. Be certain to securely tighten the terminals or wires.
- When installing the starter, install the starter in the clutch housing positively and be sure to tighten the attaching bolts to the specified torque. Improper installation can cause premature wear of the teeth of the pinion gear or ring gear and also can cause breakage of the clutch housing.

[Reference]

Starter Installing Torque: 25.9 - 48.1 N·m

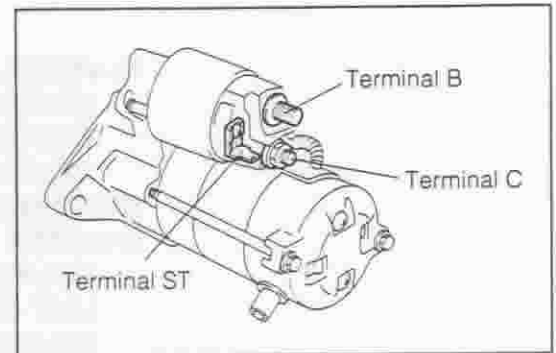

JST00003-00002

STARTER RELAY

1. Remove the lid of the relay box inside the engine compartment and pull out the starter relay.

JST00004-00000

2. Inspection of relay continuity

(1) Check that there is continuity between the terminals ① and ②.

Specified Value: 109 - 113 Ω

(2) Check that there is continuity between the terminals ③ and ④ when a voltage of 12 V is applied between the terminals ① and ②.

NOTE:

- If the trouble has not been solved by repairing the relay, check wire harness.

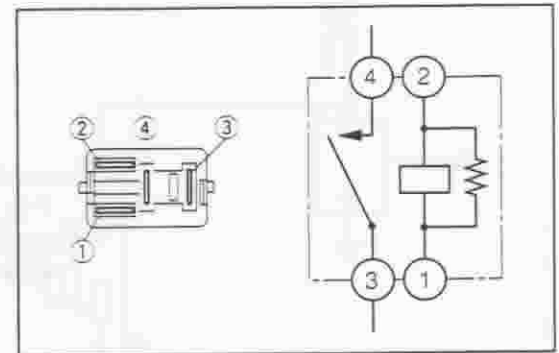

JST00005-00004

3. Install the starter relay to the relay box.

JST00006-00000

NEUTRAL START SWITCH

As for the neutral start switch check, refer to the Section EF.

JST00080-00000

STARTING SYSTEM CIRCUIT

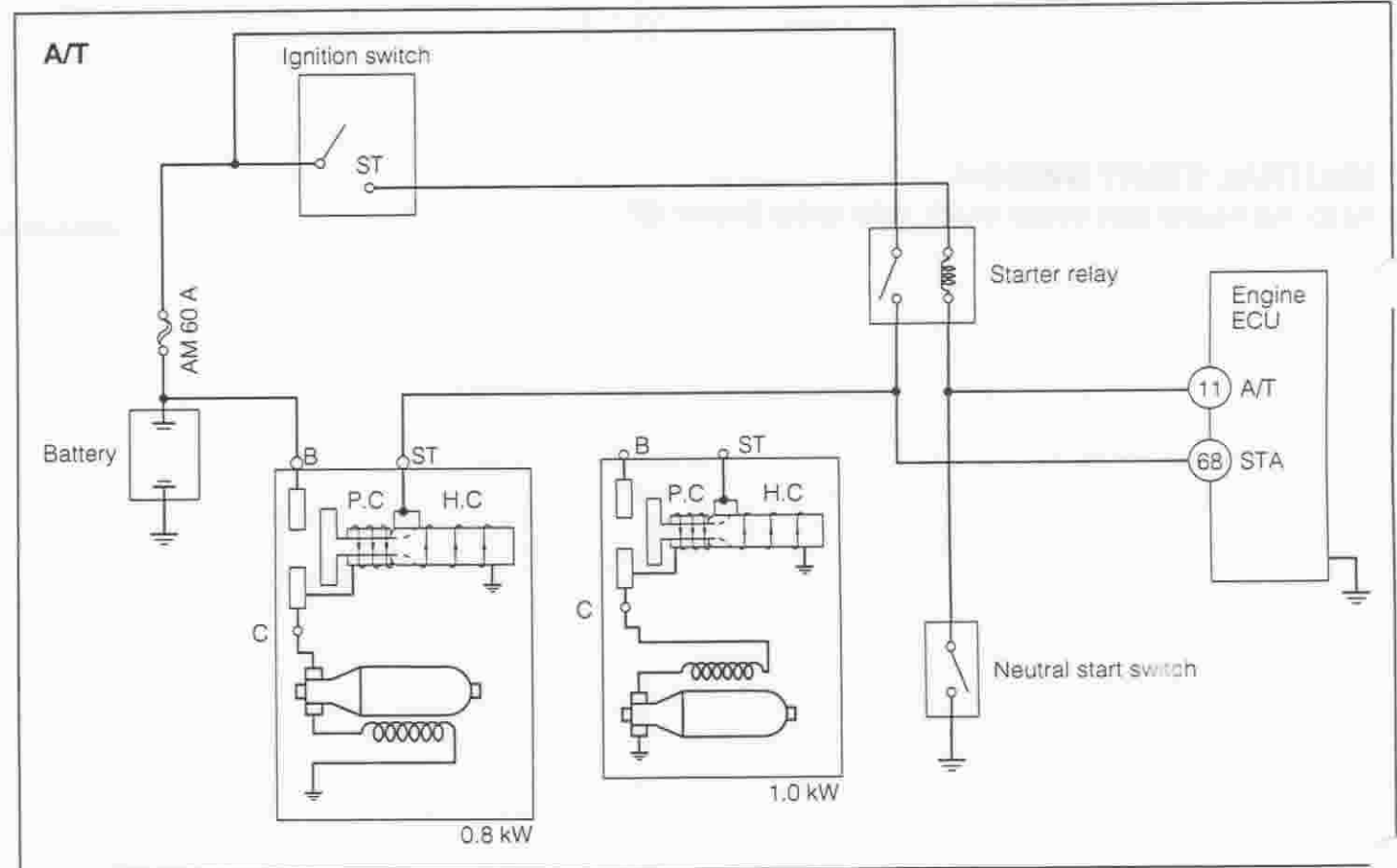
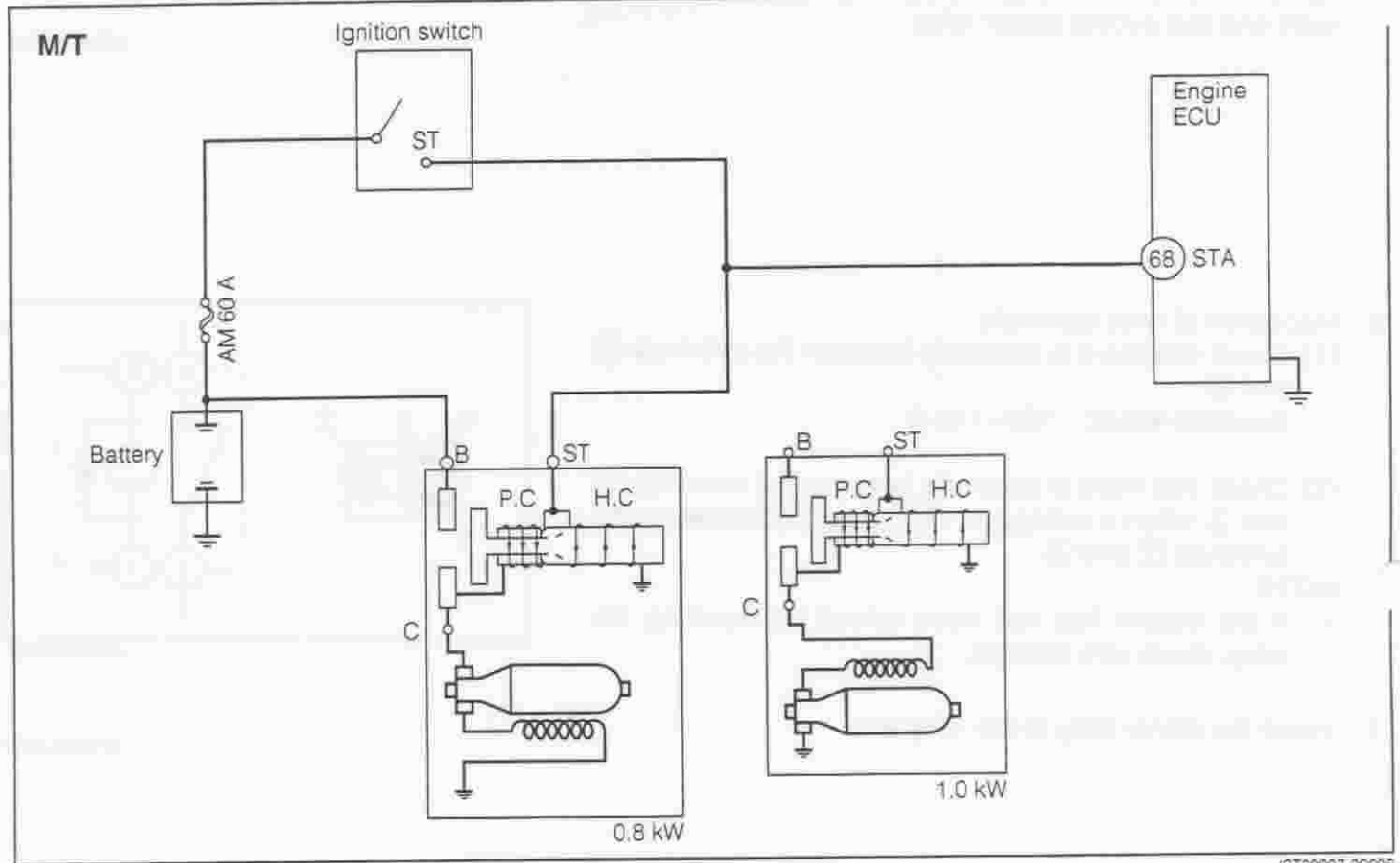

**STARTER
COMPONENTS**

RATED OUTPUT: 0.8 kW

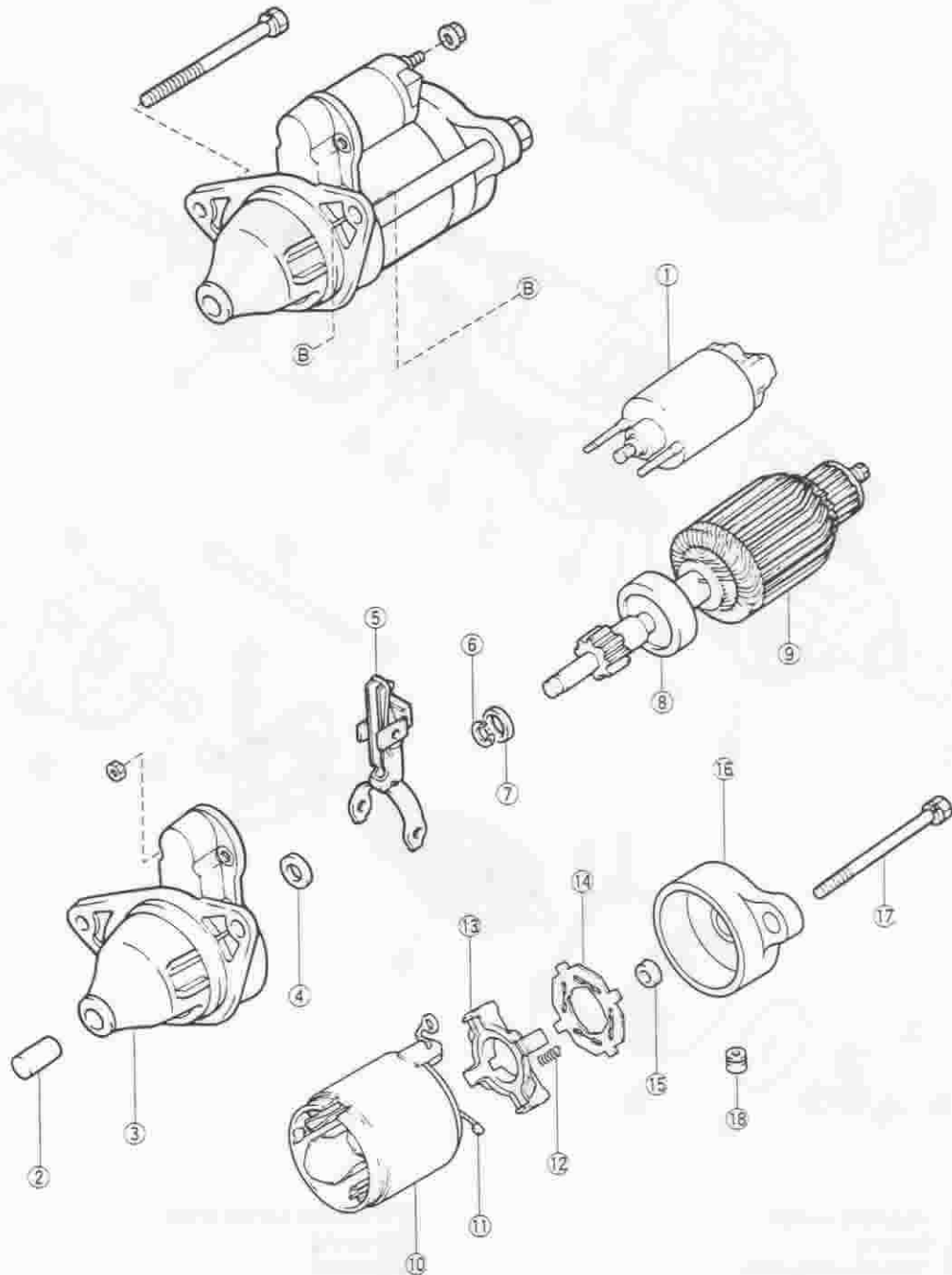

- ① Magnetic switch
- ② Bearing
- ③ Drive housing Assy
- ④ Plate washer
- ⑤ Pinion drive lever
- ⑥ Snap ring
- ⑦ Pinion stop collar
- ⑧ Starter clutch
- ⑨ Armature

- ⑩ Yoke Assy
- ⑪ Brush
- ⑫ Brush spring
- ⑬ Brush holder
- ⑭ Insulator
- ⑮ Bearing
- ⑯ Commutator end frame
- ⑰ Through bolt
- ⑱ Dust protector

JST00008-00008

RATED OUTPUT: 1.0 kW

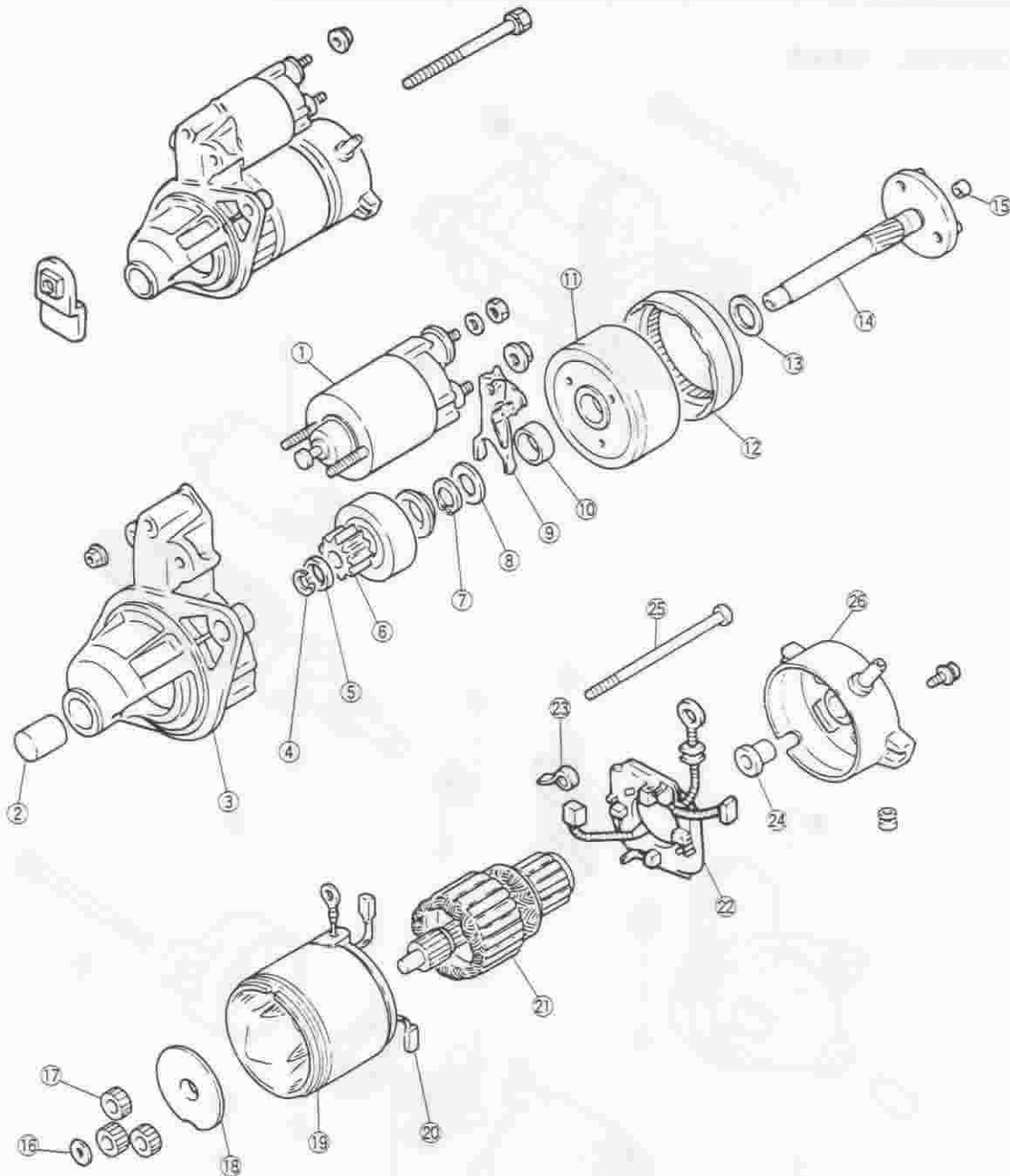

- ① Magnetic switch
- ② Bearing
- ③ Drive housing Assy
- ④ Snap ring
- ⑤ Pinion stop collar
- ⑥ Starter clutch
- ⑦ Snap ring
- ⑧ Washer
- ⑨ Pinion drive lever
- ⑩ Bearing
- ⑪ Center bearing
- ⑫ Internal gear
- ⑬ Washer

- ⑭ Planetary carrier shaft
- ⑮ Bearing
- ⑯ Washer
- ⑰ Planetary gear
- ⑱ Plate
- ⑲ Yoke Assy
- ⑳ Brush
- ㉑ Armature
- ㉒ Brush holder
- ㉓ Brush spring
- ㉔ Bearing
- ㉕ Through bolt
- ㉖ Commutator end frame

UNIT CHECK OF STARTER

CAUTION:

- Each of the following tests must be performed within three to five seconds. If you fail to observe this caution and the starter should be energized for more than this duration, the coil may be burnt out.
- If the magnet switch should be tested as a unit, there is the possibility that the switch section is damaged. Hence, be sure to test it in the assembled state.

NOTE:

- Since the magnet switch can not be overhauled, replace it if it is malfunctioning.

Pull-in test

1. Disconnect the lead wire from the terminal C of the magnetic switch.

2. Connect the negative (-) terminal of the battery to the starter body as well as to the terminal C of the magnetic switch.

3. Connect the positive (+) terminal to the terminal ST. Ensure that the pinion is pushed outward. If the drive pinion fails to move out, replace the magnetic switch.

NOTE:

- The cause for the pinion to fail to pull in is open wire in the P.C. of the magnet switch or improper sliding of the plunger. Hence, replace the magnet switch.

Hold-in test

After the check has been performed following the same procedure as the pull-in test, disconnect the negative terminal of the magnetic switch terminal.

Ensure that the drive pinion is held in a pushed-out state. If the drive pinion fails to be held, replace the magnetic switch.

NOTE:

- The cause for the pinion to fail to be held is open wire in the P.C. of the magnet switch. Hence, replace the magnet switch.

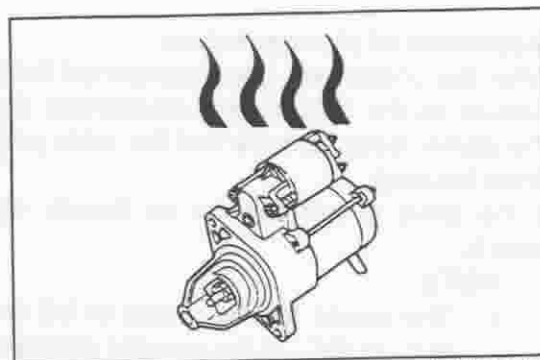

JST00009-00010

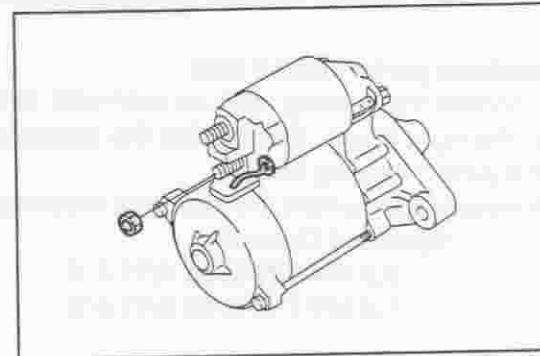

JST00010-00011

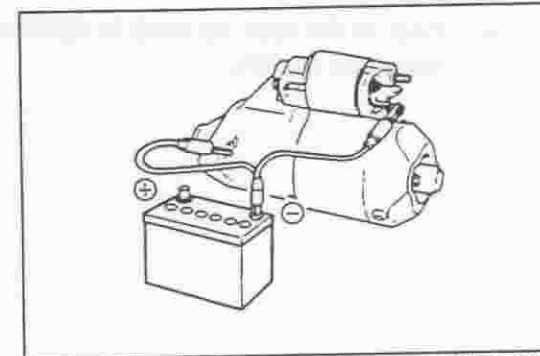

JST00011-00012

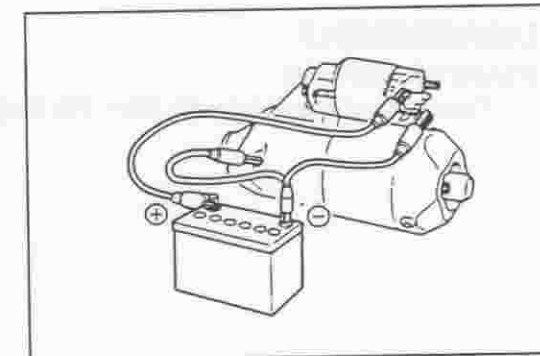

JST00012-00013

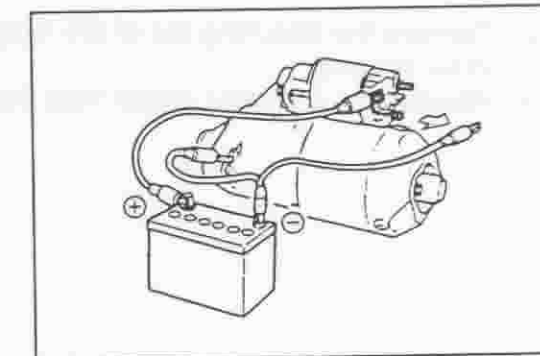

JST00013-00014

Inspection of plunger return

After the check has been performed following the same procedure as the hold-in test, disconnect the ground terminal of the starter body. Ensure that the drive pinion is drawn into the drive housing.

If the drive pinion fails to be drawn, replace the magnetic switch.

NOTE:

- The cause for the pinion to fail to return is that either H.C. or P.C. of the magnet switch is grounded or shorted. Hence, replace the magnet switch.

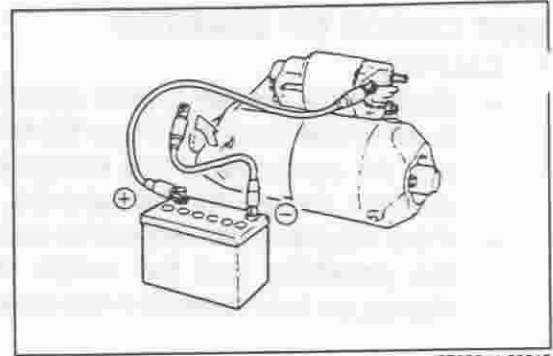

JST00014-00015

No-load performance test

Connect the battery and an ammeter to the starter as shown in the right figure. Ensure that the starter rotates smoothly with the pinion moving out.

Measure the current the starter is drawing.

Specified Current:

0.8 kW TYPE 50 A/11.5 V

1.0 kW TYPE 90 A/11.5 V

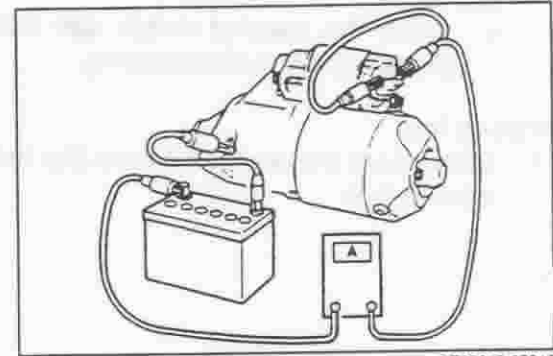

JST00015-00016

NOTE:

- Prior to the test, be sure to connect the lead wire to the magnetic switch.

DISASSEMBLY**STARTER (0.8 kW)**

1. Disconnect the lead wire from the magnetic switch.

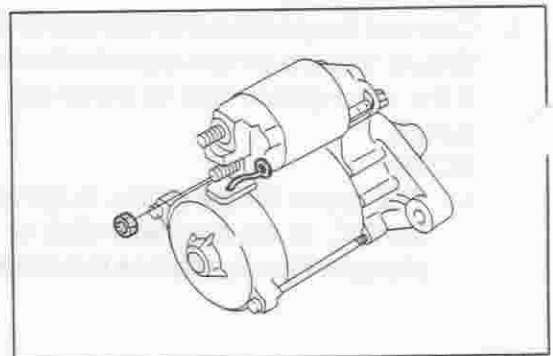

JST00016-00017

2. Remove the attaching nut of the magnetic switch from the drive housing.
3. Remove the magnetic switch from the drive housing.

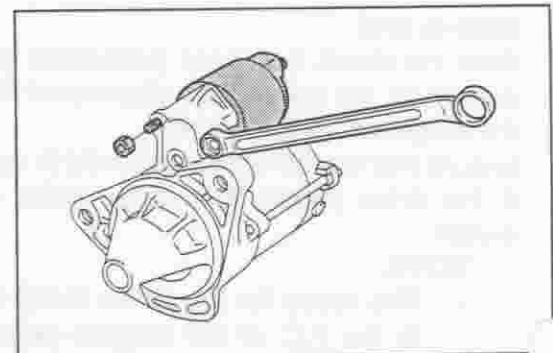

JST00017-00018

- 4. Remove the commutator end frame cover by removing the two screws.

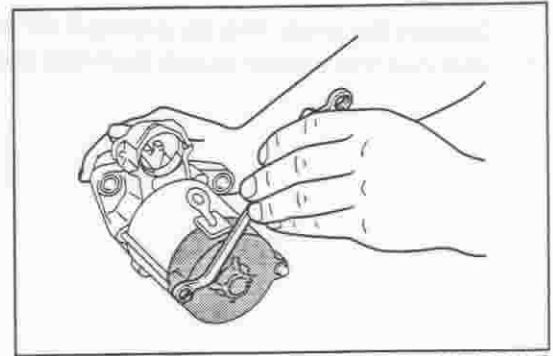

JST00018-00019

- 5. Remove the insulator from the brush holder.
- 6. Remove the brush spring and brush from the brush holder.

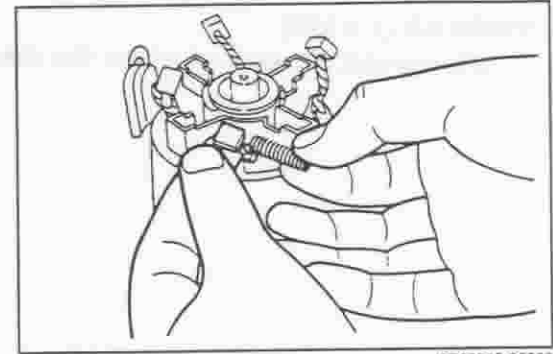

JST00019-00020

- 7. Remove the brush holder from the yoke.

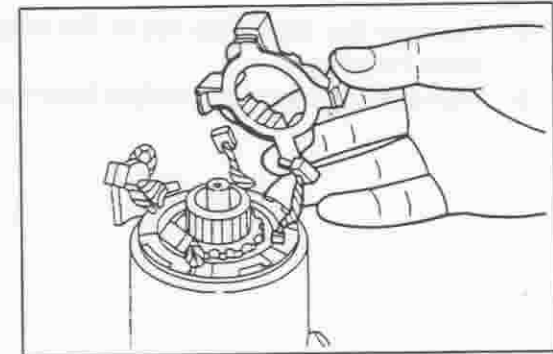

JST00020-00021

- 8. Remove the yoke from the armature.
- 9. Remove the pinion drive lever and the armature from the drive housing.

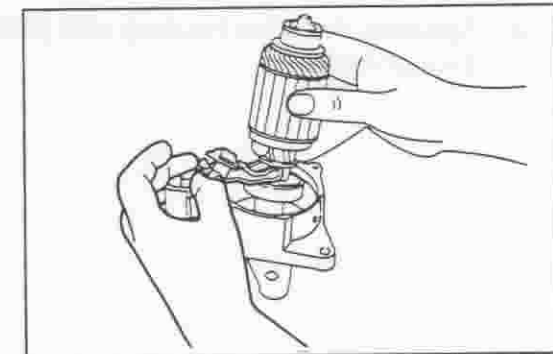

JST00021-00022

- 10. With the SST put over the shaft, lightly tap the SST so as to remove the pinion stop collar from the snap ring.
SST: 09238-87701-000

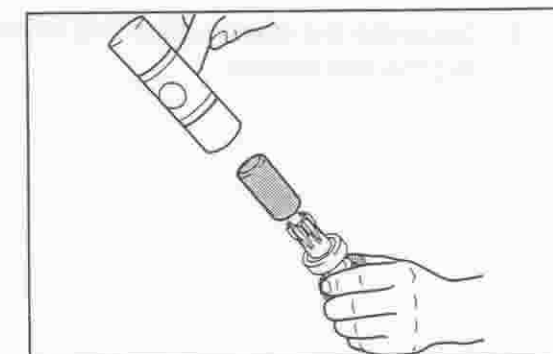

JST00022-00023

11. Detach the snap ring by prying it off with snap ring pliers.
12. Remove the starter clutch from the shaft.

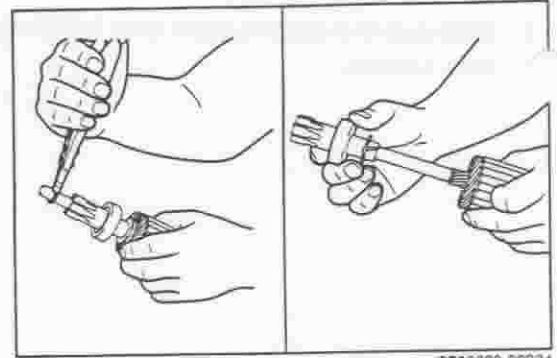

JST00023-00024

STARTER (1.0 kW)

1. Disconnect the lead wire from the magnetic switch.

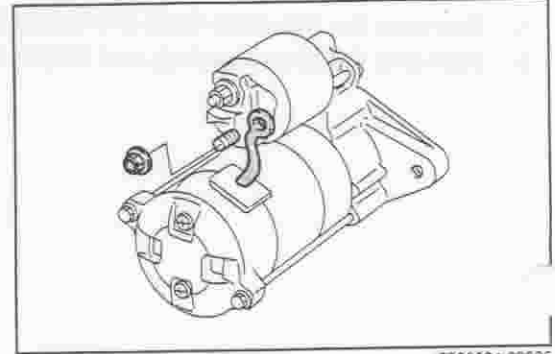

JST00024-00025

2. Remove the attaching nut of the magnetic switch from the drive housing.
3. Remove the magnetic switch from the drive housing.

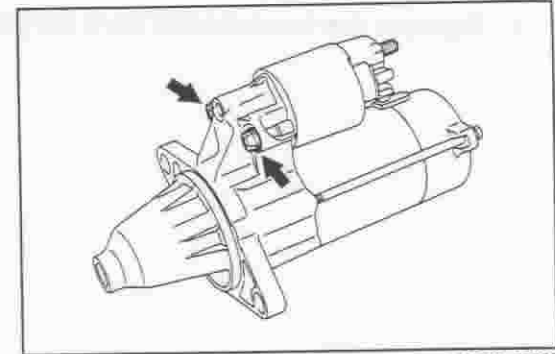

JST00025-00026

4. Separate the drive housing and yoke by removing the two through bolts.

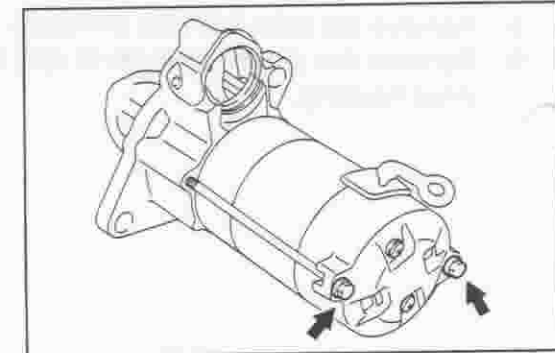

JST00026-00027

5. Separate the commutator end frame and yoke by removing the two screws.

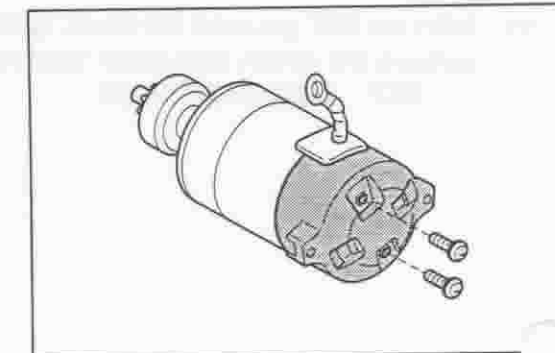

JST00027-00028

6. Separate the yoke and center bearing.

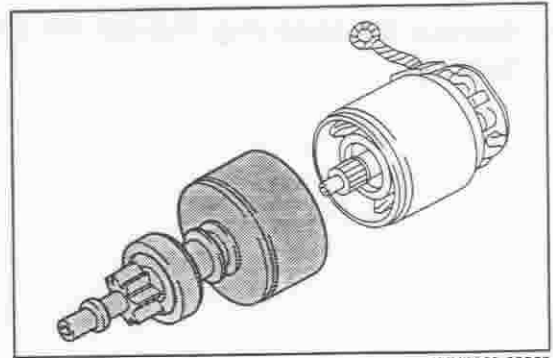

JST00028-00029

7. Pull out the armature from the yoke.

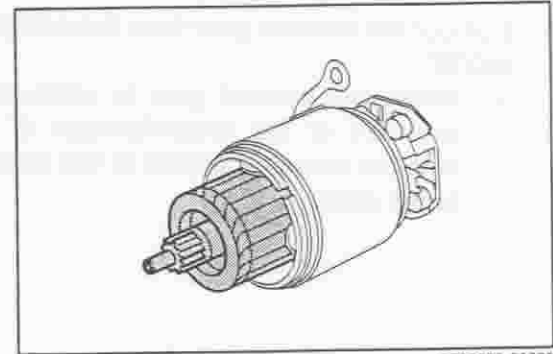

JST00029-00030

8. Remove the brushes from the brush holder by lifting the brush springs by means of nose pliers or the like.

NOTE:

- Care must be exercised not to scratch the commutator during the removal.

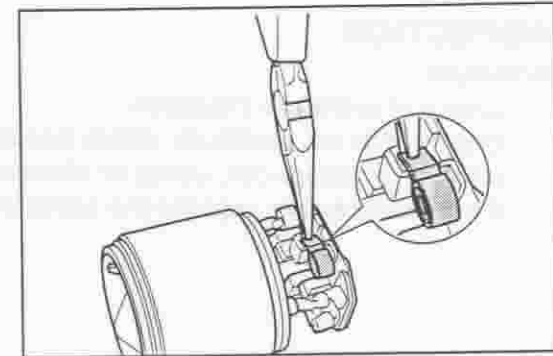

JST00030-00031

9. Remove the plate from the center bearing.

10. Remove the planetary gears.

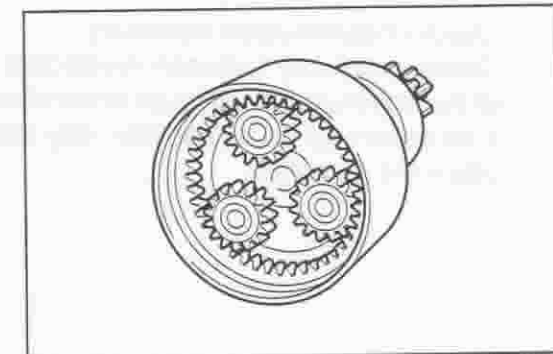

JST00031-00032

11. With the SST put over the shaft, lightly tap the SST so as to remove the pinion stop collar from the snap ring.

SST: 09238-87701-000

12. Remove the snap ring from the shaft. Remove the starter clutch from the shaft.

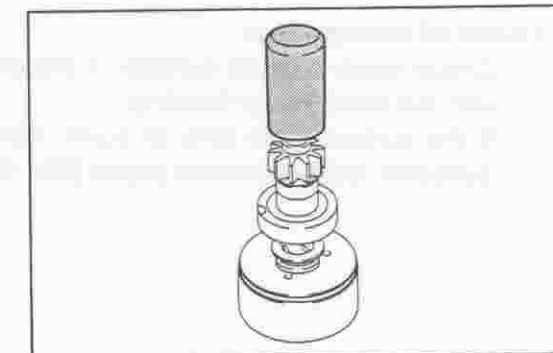

JST00032-00033

13. Remove the snap ring. Pull out the shaft from the center bearing.

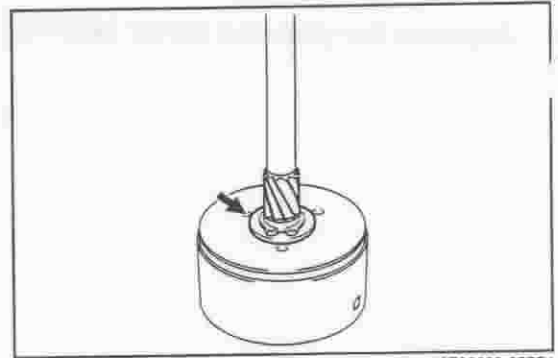

JST00033-00034

14. Pull out the internal gear from the center bearing.
NOTE:

- When the internal gear is removed, align the recess provided at the circumference of the center bearing with the recess provided at the circumference of the internal gear.

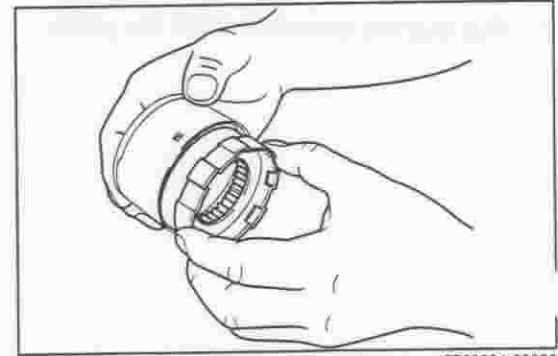

JST00034-00035

INSPECTION

Armature

1. Check of armature insulation
Ensure that no continuity exists between the commutator and the armature coil, using an ohmmeter. If continuity exists, replace the armature.
2. Check of commutator continuity
Check continuity between respective adjacent segments of the commutator, using an ohmmeter. If no continuity exists between any adjacent segments, replace the armature.

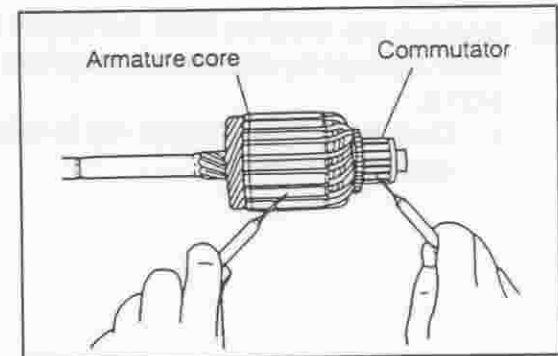

JST00035-00036

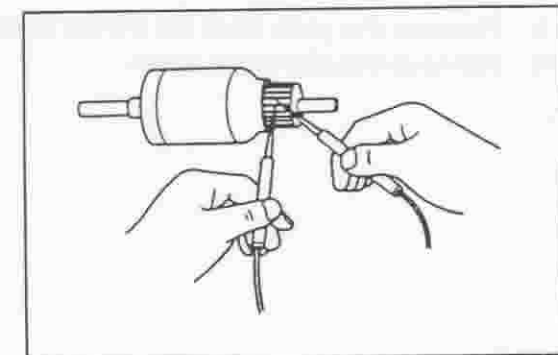

JST00036-00037

Check of commutator

1. Check each contact surface of the commutator segments with the brushes for burning. If the surfaces are dirty or burnt, correct the commutator surfaces, using abrasive paper (No. 400) or a lathe.

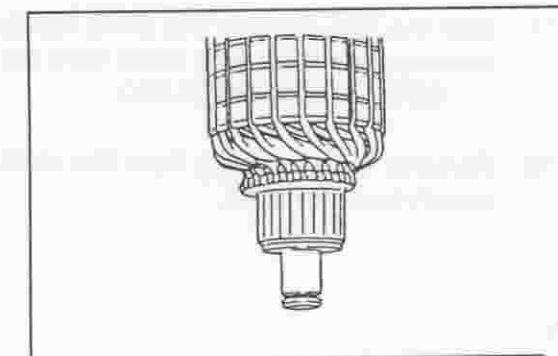

JST00037-00038

2. Check of commutator for circle runout
Support the armature at its both ends on a V-block.
Check the commutator for circle runout, using a dial gauge.

Standard Circle Runout:

0.8 kW TYPE: 0.05 mm
1.0 kW TYPE: 0.02 mm

Limit:

0.8 kW TYPE: 0.40 mm
1.0 kW TYPE: 0.05 mm

If the circle runout exceeds the allowable limit, turn down the commutator on a lathe.
At this point, care must be exercised to ensure that the commutator diameters are not less than the minimum required diameter of 27 mm.

3. Measurement of commutator diameter
Measure the commutator diameter by means of a micrometer or vernier calipers.

Standard Diameter: 28 mm
Minimum Diameter: 27 mm

If the commutator diameter is less than the minimum diameter, replace the armature.

4. Check of commutator undercut depth
If the depth of the insulator groove between commutator segments is less than 0.2 mm, it is necessary to undercut the insulator so that the groove depth may become 0.45 - 0.75 mm.

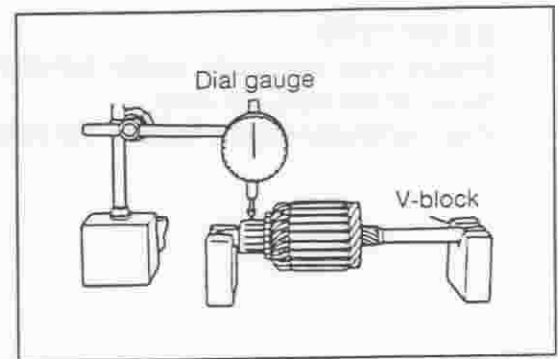

JST00038-00039

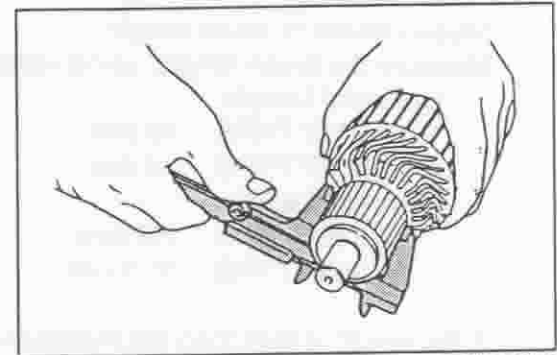

JST00039-00040

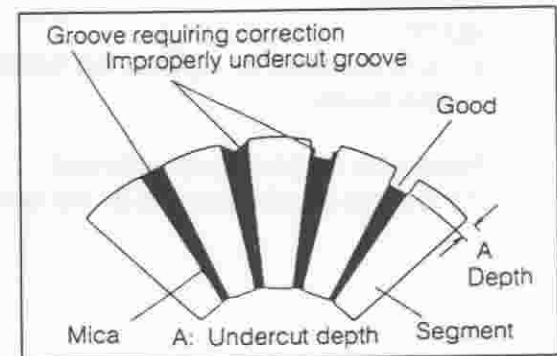

JST00040-00041

Check of field coil

1. Field coil continuity test
Perform field coil continuity test at a point between the lead wires (brush), using an ohmmeter.
If no continuity exists, replace the yoke.

0.8 kW TYPE: 4 lead wires are available
1.0 kW TYPE: 2 lead wires are available

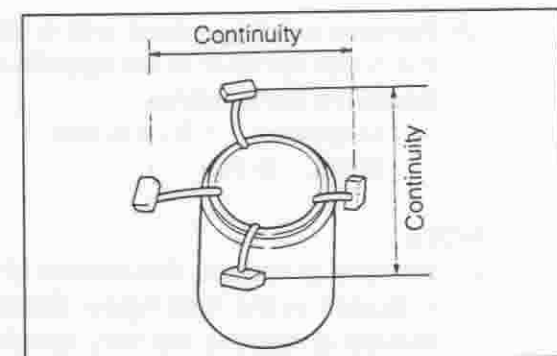

JST00041-00042

2. Field coil short test

1.0 kW TYPE

Perform field coil short test at a point between the brush and the yoke proper, using an ohmmeter.
If continuity exists, replace the yoke.

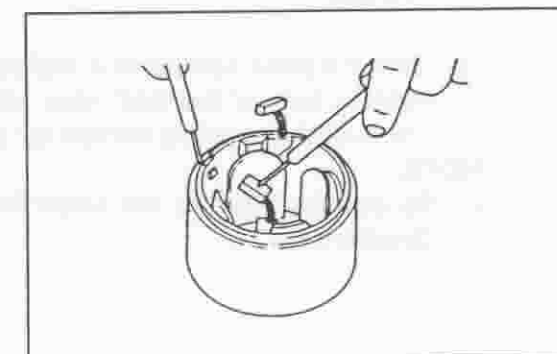

JST00042-00043

0.8 kW TYPE

Ensure that continuity exists between the yoke and the brush at the field coil side.
If no continuity exists, replace the yoke.

Check of brushes

1. Measurement of brush length
Measure the brush length, using vernier calipers.

Standard Length:

0.8 kW TYPE: 10 mm

1.0 kW TYPE: 14 mm

Minimum Length:

0.8 kW TYPE: 7.8 mm

1.0 kW TYPE: 11.1 mm

If the length is less than the minimum requirement, replace the brush.

NOTE:

- It is possible to replace the brush holder or yoke with the brush.

2. Procedure for brush replacement

(1) Cut the brush lead wire at the terminal side.

(2) Remove welding traces with a file or the like to correct the brush terminal to the specified dimensions.

Specified Dimensions:

Thickness: 1.3 - 1.5 mm

Width: 5 mm

NOTE:

- Be sure to remove the section of the brush terminal as indicated in the right figure. Since the section to be removed is narrow, be very careful not to damage the field coil.

(3) Stick the plate section of a replacement brush onto the welding side of the lead wire. Make pressure connection over the overlaid section by pinching it with pliers.

NOTE:

- Be sure to take out the brush lead wire in the correct direction.

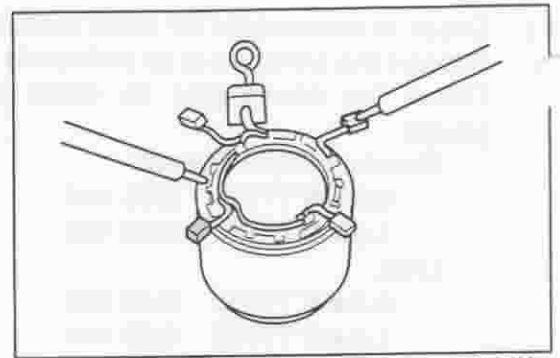

JST00043-00044

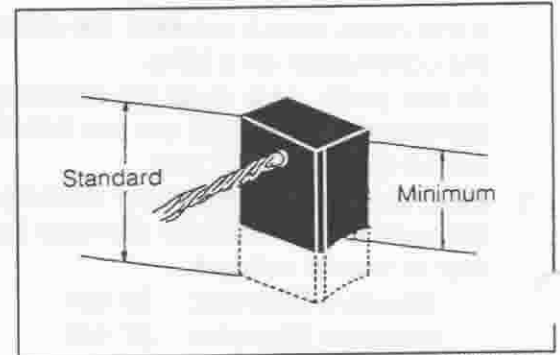

JST00044-00045

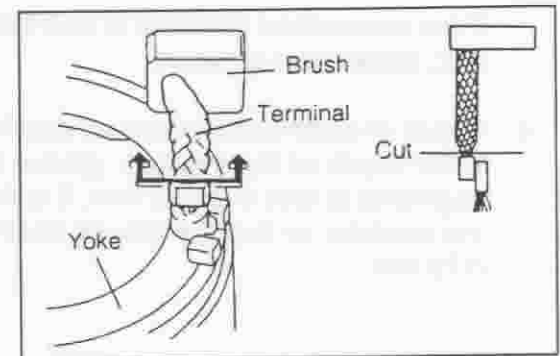

JST00045-00046

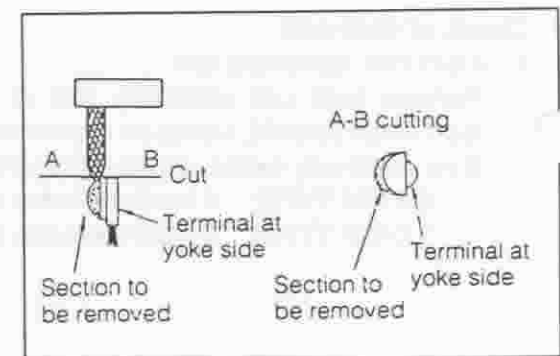

JST00046-00047

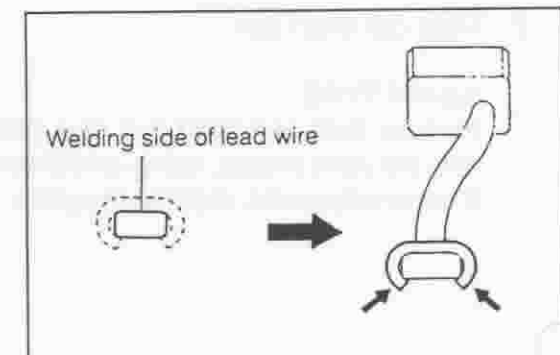

JST00047-00048

- (4) Solder the pressure connection. Correct the section, using a file or the like, so that the section conforms to the dimensions, as indicated in the right figure.

NOTE:

- When performing the soldering, heat the section to be soldered thoroughly. Be very careful not to allow any solder to flow into the positive side lead wire.
- Be sure to allow solder in a sufficient amount to flow into the inside of the plate.
- Ensure that no solder oozes to the field side.

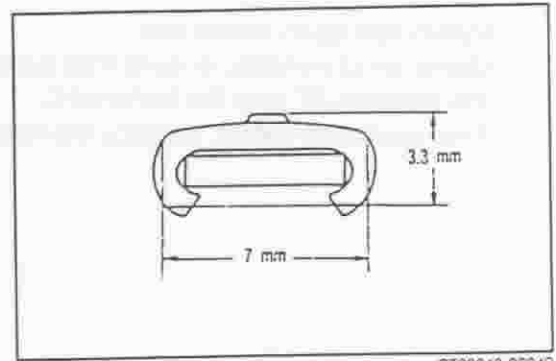

JST00048-00049

Check of brush holder (Only for 1.0 kW TYPE)

1. Check of brush holder for insulation
Measure the insulation between the positive and negative terminal of the brush holder.

Insulation Resistance: 0.1 MΩ or more

If the insulation resistance is less than the specification, replace the brush holder.

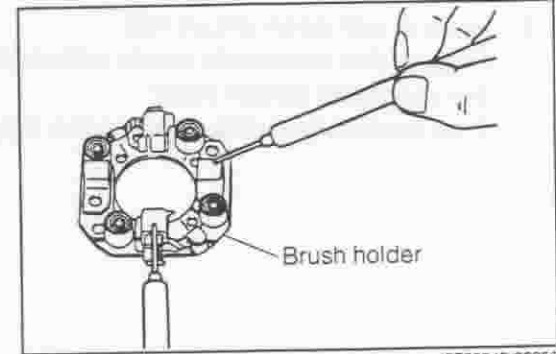

JST00049-00050

Check of starter clutch

1. Inspection of pinion gear and spline teeth
Check the teeth of the pinion gear and spline for wear or damage.
If any damage exists, replace the clutch. Also, inspect the flywheel ring gear for wear or damage.

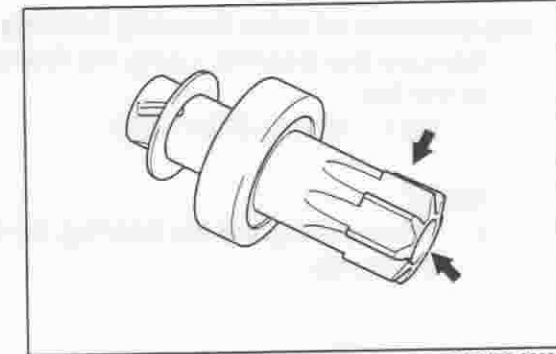

JST00050-00051

2. Check of starter clutch
While holding the clutch, turn the pinion clockwise. Ensure that the pinion turns smoothly.
Turn the pinion counterclockwise. Ensure that the pinion is locked.
If the check results are unsatisfactory, replace the starter clutch.

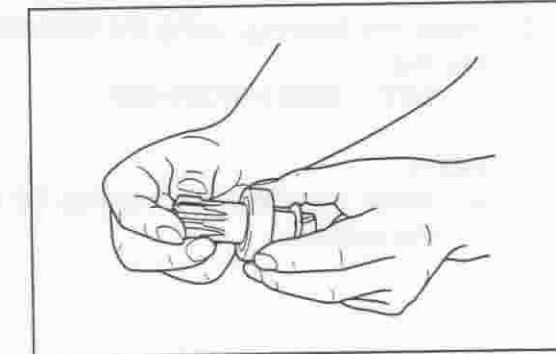

JST00051-00052

Check of magnetic switch

1. Plunger check
Push in the plunger with your fingers and release your fingers. Ensure that the plunger returns quickly to the original position. If the plunger exhibits poor returning or fails to return, replace the magnetic switch.

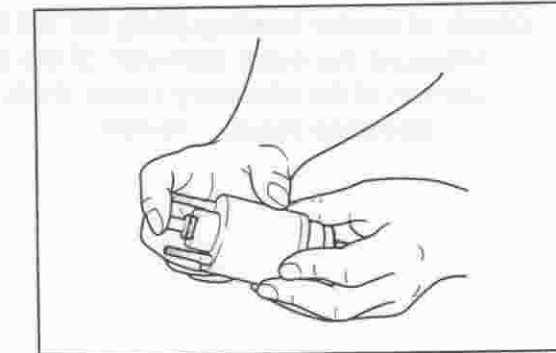

JST00052-00053

2. Pull-in coil open circuit test
Using an ohmmeter, ensure that continuity exists between the terminal ST and the terminal C.
If no continuity exists, replace the magnetic switch.

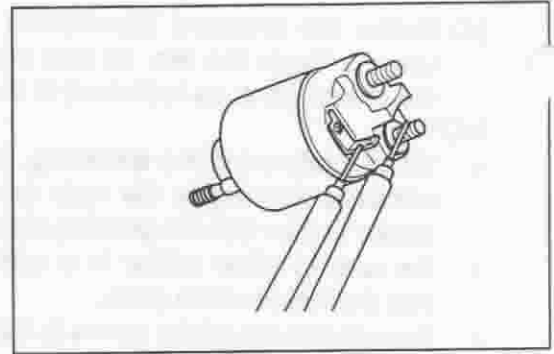

JST00053-00054

3. Hold-in coil open circuit test
Ensure that continuity exists between the terminal ST and the magnetic switch body.
If no continuity exists, replace the magnetic switch.

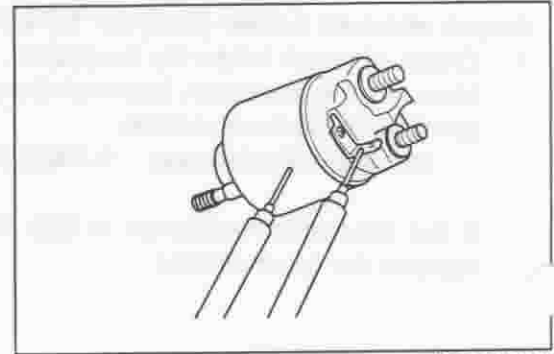

JST00054-00055

Replacement of drive housing bearing

1. Remove the bearing, using the following SST with a press or the like.

SST: 09221-87301-000

NOTE:

- When pulling out the bearing, be sure to remove it from the inside.

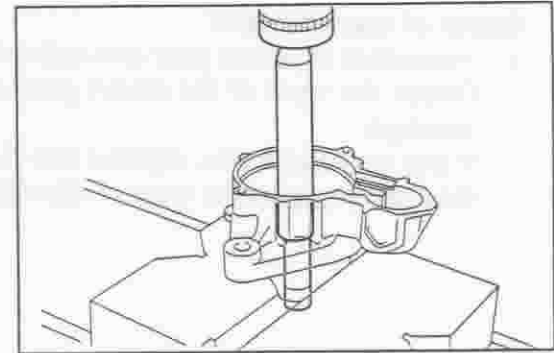

JST00080-00080

2. Install the bearing, using the following SST with a press or the like.

SST: 09221-87301-000

NOTE:

- When installing the bearing, be sure to install it from the outside.

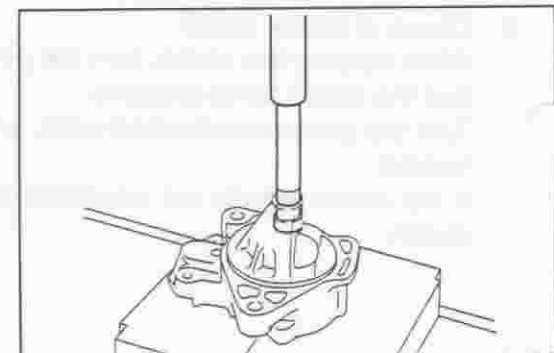

JST00081-00081

Check of center bearing (Only for 1.0 kW TYPE)

1. Measure the outer diameter of the center bearing sliding section of the planetary carrier shaft.

Specified Value: 15 mm

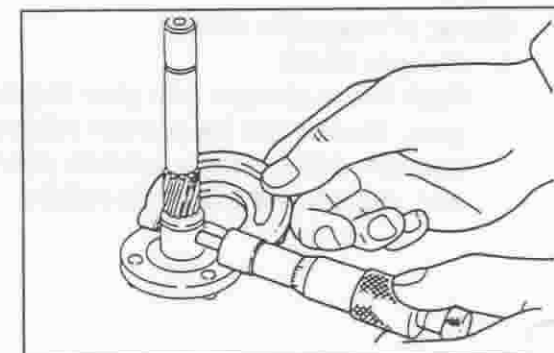

JST00082-00082

2. Measure the inner diameter of the center bearing so as to determine the clearance.

Specified Value: 0.03 mm
 Allowable Limit: 0.10 mm

If the clearance exceeds the allowable limit, replace the bearing or the planetary carrier shaft.

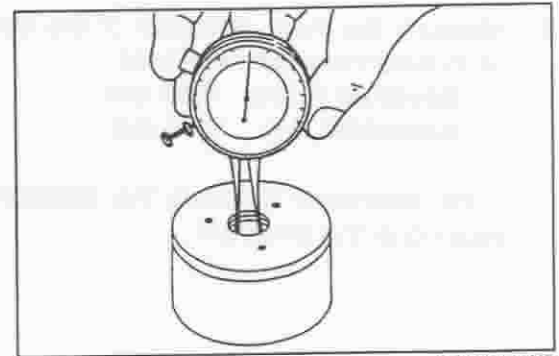

JST00083-00083

3. Bearing replacement

- (1) Remove the bearing, using a suitable tool in combination with a press or the like.

NOTE:

- When pulling out the bearing, be sure to remove it from the inside.

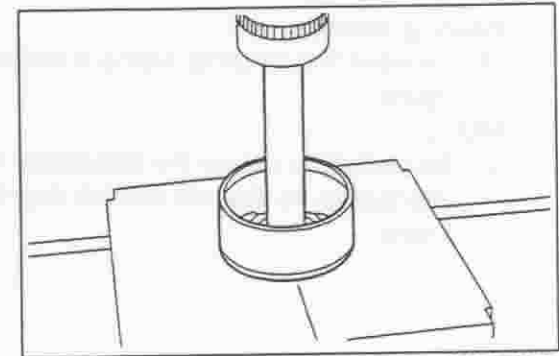

JST00084-00084

- (2) Install the bearing, using a suitable tool in combination with a press or the like.

NOTE:

- When installing the bearing, be sure to install it from the outside.

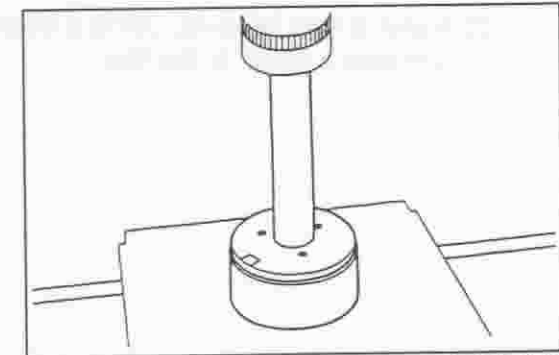

JST00085-00085

NOTE:

- The bearing should be driven into position in such a way that the bearing is recessed within 0.5 mm from the edge of the center bearing.

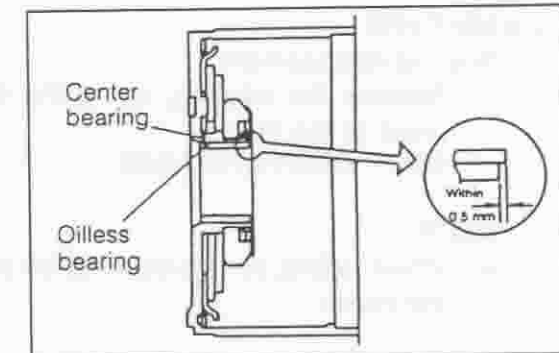

JST00086-00086

Check of end frame bearing
1.0 kW TYPE

1. Measure the outer diameter of the end frame sliding section of the armature shaft.

Specified Value: 7 mm

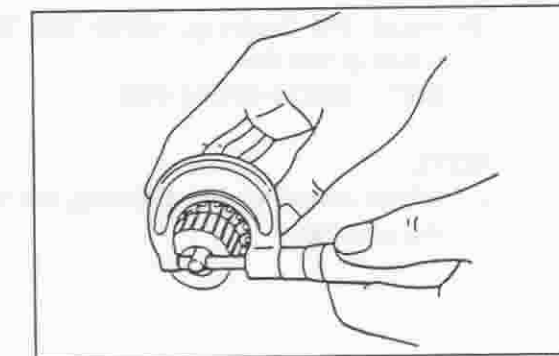

JST00087-00087

2. Measure the inner diameter of the end frame bearing so as to determine the clearance.
 Specified Value: 0.03 mm
 Allowable Limit: 0.10 mm

If the clearance exceeds the allowable limit, replace the bearing or the armature.

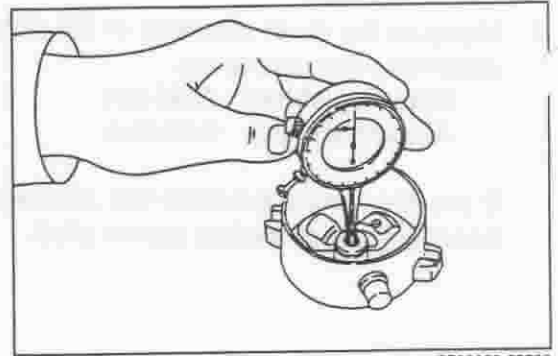

JST00088-00088

3. Bearing replacement
 (1) Remove the bearing, using a tap as shown in the right figure.

NOTE:

- Be certain to clamp the end frame in a vise with a cloth interposed so that no scratch may be made on the end frame.

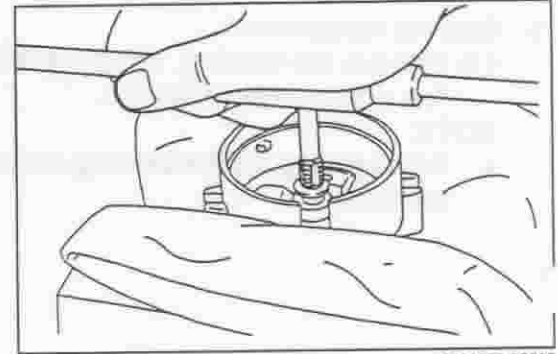

JST00089-00089

- (2) Install a new bearing, using a suitable tool in combination with a press or the like.

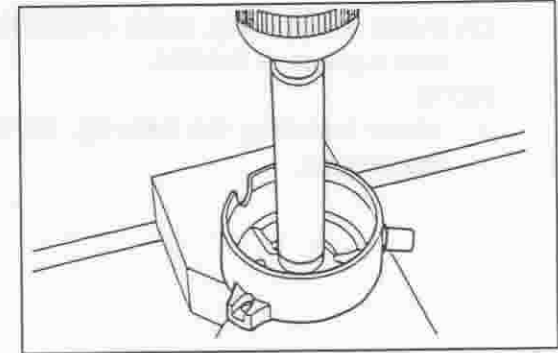

JST00090-00090

0.8 kW TYPE

1. Bearing replacement
 (1) Remove the bearing, using the following SST with a press or the like.
 SST: 09221-87301-000

NOTE:

- When pulling out the bearing, be sure to remove it from the inside.

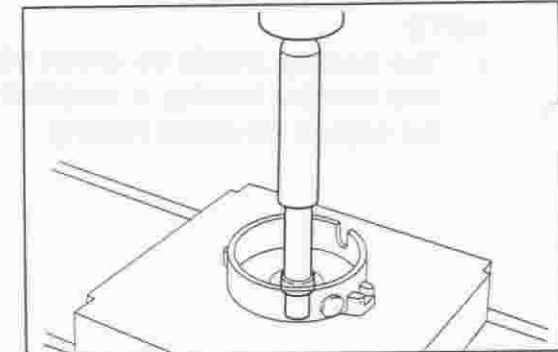

JST00091-00091

- (2) Install the bearing, using the following SST with a press or the like.
 SST: 09221-87301-000

NOTE:

- When installing the bearing, be sure to install it from the outside.

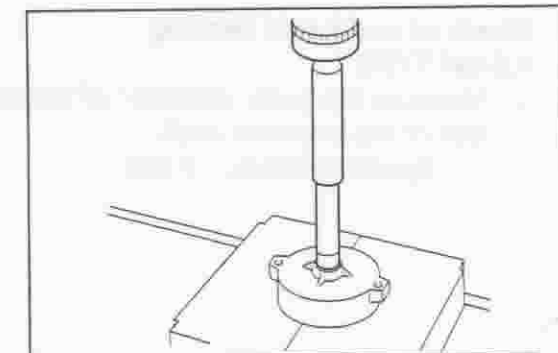

JST00092-00092

ASSEMBLY

NOTE:

- Use high-temperature grease to lubricate the bearings and sliding parts when assembling the starter.

STARTER (0.8 kW)

1. Install the starter clutch on the armature shaft.
 2. Pass the pinion stop collar on the armature shaft.
 3. Fit the new snap ring onto the armature shaft.
-
4. With the starter clutch pushed up, lightly tap the shaft with a plastic hammer so as to fit the pinion stop collar onto the snap ring.

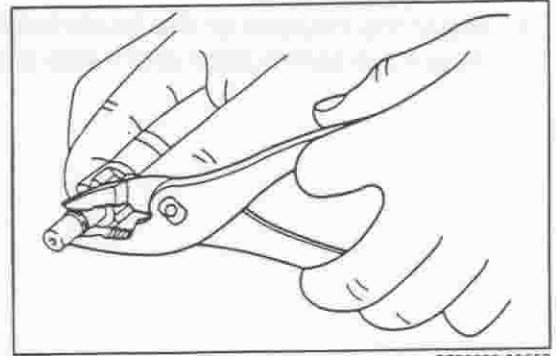

JST00058-00059

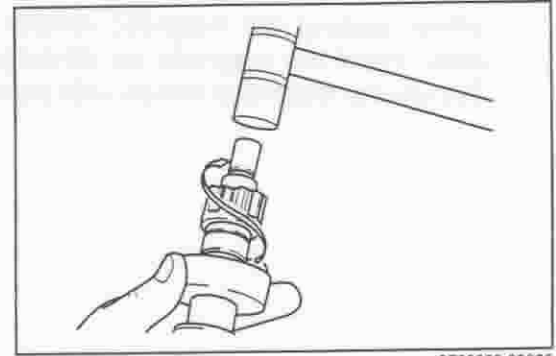

JST00059-00060

5. Install the pinion drive lever and armature in the drive housing.

NOTE:

- Apply high-temperature grease to the sliding sections of the armature shaft and drive lever.

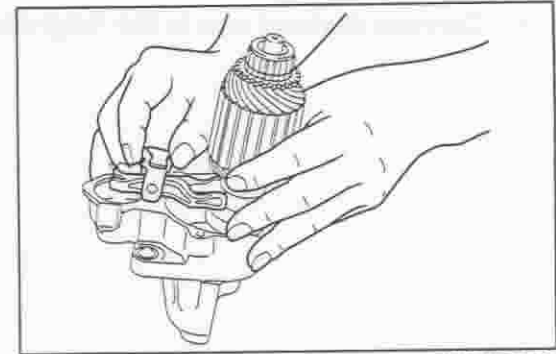

JST00060-00061

6. Install the yoke in the drive housing.

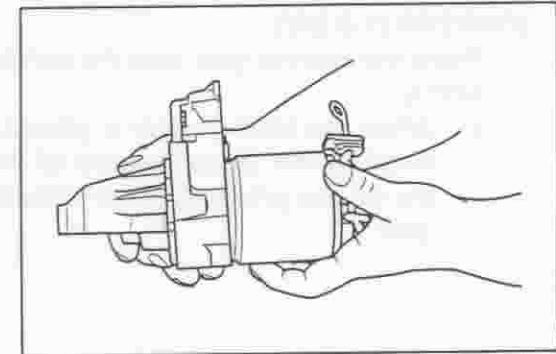

JST00061-00062

7. Install the brush holder over the armature shaft.
8. Install the brush and brush spring in the brush holder.

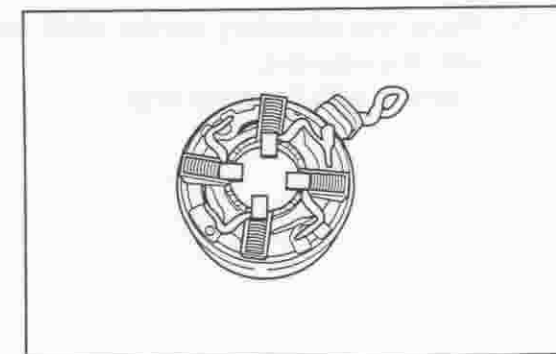

JST00062-00063

9. Install the insulator on the brush holder.
10. Attach the commutator end frame to the yoke assembly.

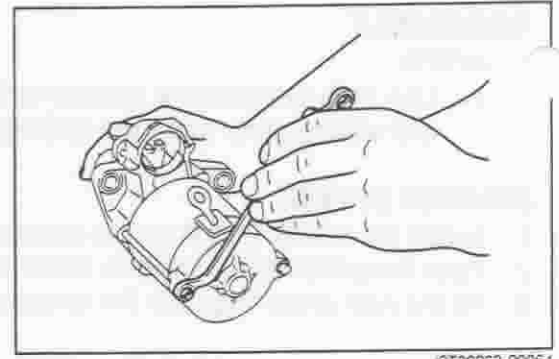

JST00063-00064

11. While hooking the magnetic switch over the pinion drive lever, install the magnetic switch onto the drive housing. Secure the magnetic switch with the two nuts.

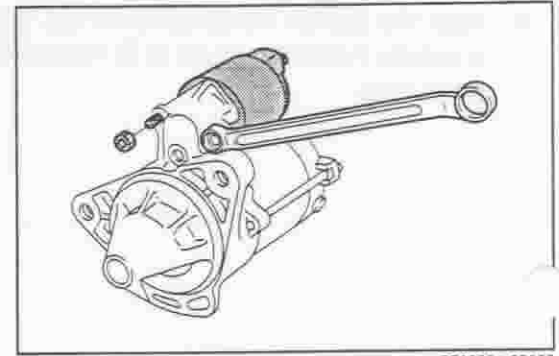

JST00064-00065

12. Connect the lead wire to the magnetic switch.

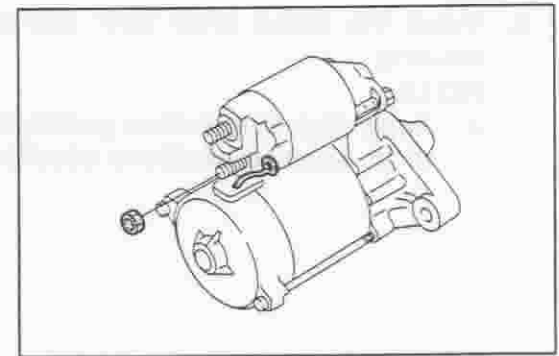

JST00065-00066

STARTER (1.0 kW)

1. Place the internal gear into the center bearing.

NOTE:

- When the internal gear is placed, align the recess provided at the circumference of the center bearing with the recess provided at the circumference of the internal gear.

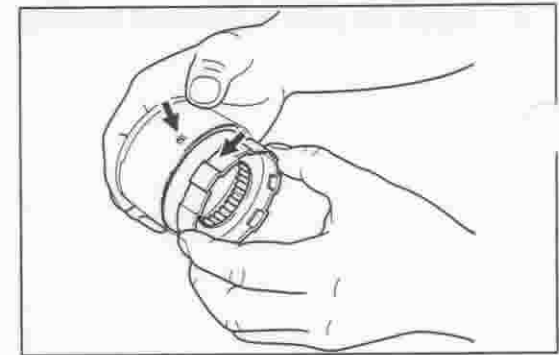
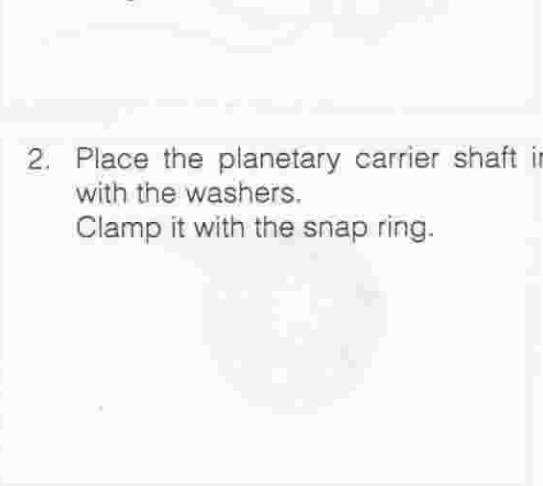

JST00066-00067

2. Place the planetary carrier shaft into the center bearing with the washers. Clamp it with the snap ring.

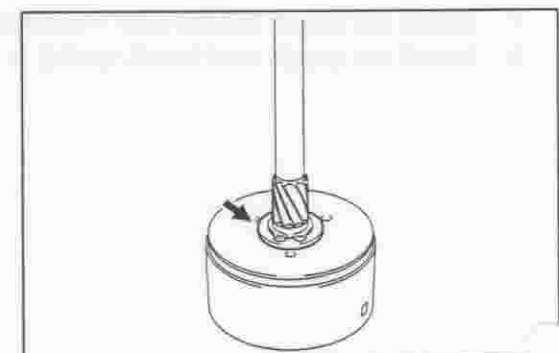

JST00067-00068

3. Pass the pinion stop collar through the center bearing shaft.
Then, attach the new snap ring to the shaft groove.

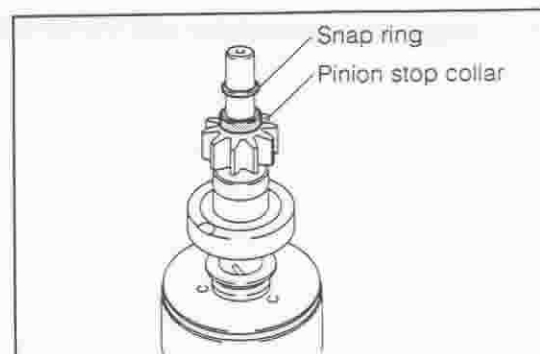

JST00068-00069

4. With the starter clutch pushed up, lightly tap the shaft with a plastic hammer so as to fit the pinion stop collar onto the snap ring.

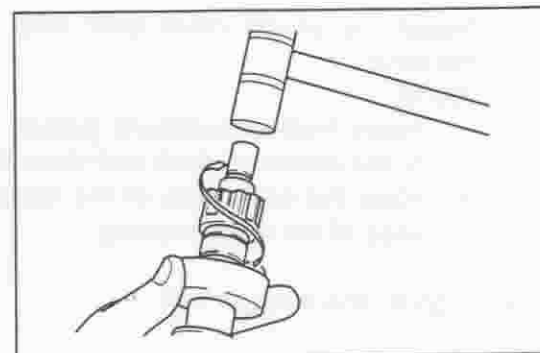

JST00069-00070

5. Install the planetary gear to the planet carrier.

NOTE:

- Apply high-temperature grease to the gear sections of the planetary gears.

6. Install the plate to the center bearing.

NOTE:

- During the installation, be sure to align the recess provided at the circumference of the plate with the recess provided at the circumference of the center bearing.

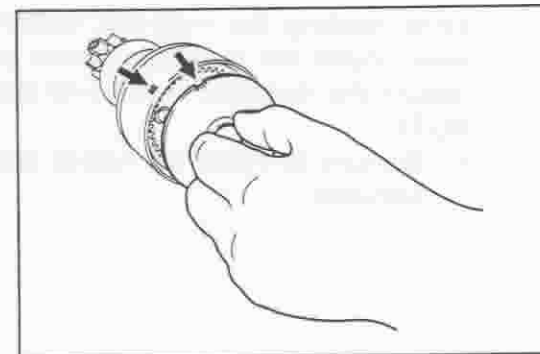

JST00070-00071

7. Place the armature in the yoke.
8. Place the brush in the brush holder.

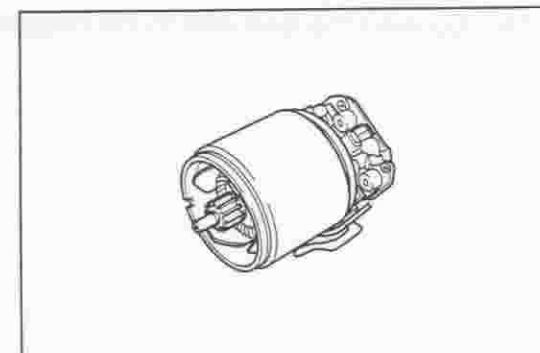

JST00071-00072

9. Connect the center bearing with the yoke.

NOTE:

- During connection, be sure to align the recess sections at the connecting section.

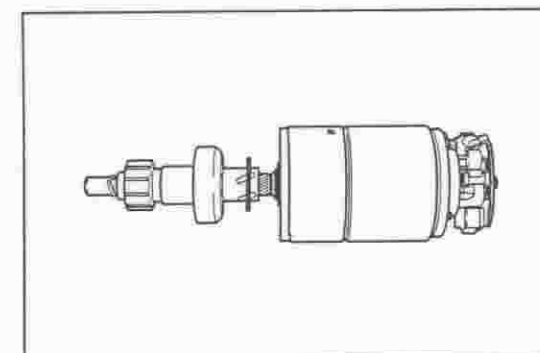

JST00072-00073

10. Install the commutator end frame to the yoke.

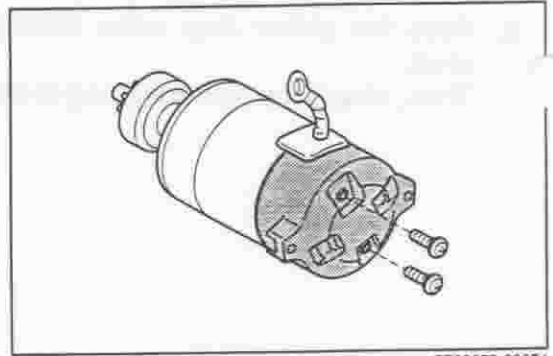

JST00073-00074

11. Install the pinion drive lever and armature in the drive housing.

NOTE:

- Apply high-temperature grease to the sliding sections of the armature shaft and drive lever.
- Align the protrusion of the center bearing with the recess of the drive housing.

12. Tighten the through bolt.

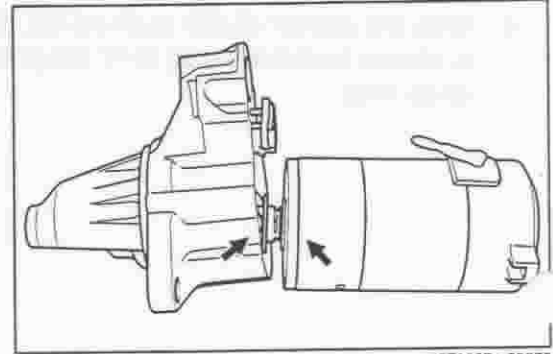

JST00074-00075

13. While hooking the magnetic switch over the pinion drive lever, install the magnetic switch onto the drive housing. Secure the magnetic switch with the two nuts.

NOTE:

- Be sure to install the rubber boot in the spring section securely.

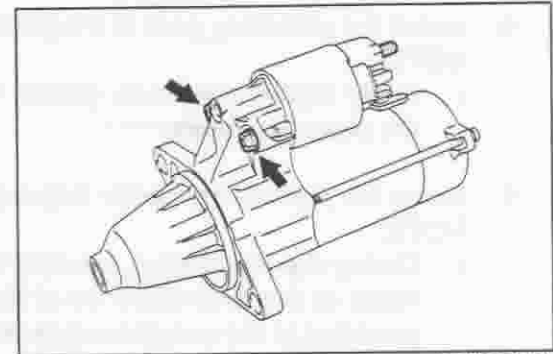

JST00075-00076

14. Connect the lead wire to the magnetic switch.

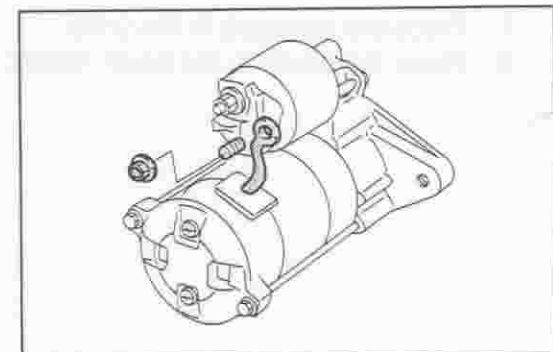



JST00076-00077

Commutator	Undercut depth	Allowable limit	0.45 - 0.75 mm	0.45 - 0.75 mm
		Specified value	0.2 mm	0.2 mm
Maximum circle runout		Specified value	0.05 mm	0.02 mm
		Allowable limit	0.4 mm	0.05 mm

JST00077-00000

SSTs

Shape	Part number	Part name
	09238-87701-000	Remover & Replacer
	09221-87301-000	Remover & Replacer

JST00076-00076

TIGHTENING TORQUE

Tightening components	Tightening torque	
	N·m	kgf·m
Starter x Engine	25.9 - 48.1	2.6 - 4.9

JST00079-00000