

---

# **ENGINE COOLING**

---

# ENGINE COOLING

## CONTENTS

<b>GENERAL INFORMATION</b> .....	2	Engine Coolant Replacement .....	9
<b>SERVICE SPECIFICATIONS</b> .....	2	Concentration Measurement .....	10
<b>LUBRICANT</b> .....	2	Fan Controller Check .....	10
<b>SEALANTS</b> .....	3	Fan Control Relay Continuity Check .....	11
<b>SPECIAL TOOL</b> .....	3	<b>THERMOSTAT</b> .....	12
<b>TROUBLESHOOTING</b> .....	3	<b>WATER PUMP</b> .....	14
<b>ON-VEHICLE SERVICE</b> .....	8	<b>WATER HOSE AND WATER PIPE</b> .....	15
Engine Coolant Leak Checking .....	8	<b>RADIATOR</b> .....	18
Radiator Cap Valve Opening Pressure Check ...	8		

---

## GENERAL INFORMATION

The cooling system is designed to keep every part of the engine at appropriate temperature in whatever condition the engine may be operated.

The cooling method is of the water-cooled, pressure forced circulation type in which the water pump pressurizes coolant and circulates it throughout the engine. If the coolant temperature exceeds the prescribed temperature, the thermostat opens to circulate the coolant through the radiator as well so that the heat absorbed by the coolant may be radiated into the air.

The water pump is of the centrifugal type and is driven by the timing belt from the crankshaft.

The radiator is the corrugated fin, down flow type and is cooled by the electrical radiator fan.

The cooling fans are controlled by a fan controller and the engine-ECU depending on driving conditions.

Items			Specifications
Radiator	Performance kJ/h	M/T	152,791
		A/T	169,535
A/T oil cooler	Performance kJ/h		5,652

### NOTE

\*: Vehicles with optional radiator

## SERVICE SPECIFICATIONS

Items		Standard value	Limit
Radiator cap opening pressure kPa		74 – 103	64
Range of coolant antifreeze concentration of radiator %		30 – 60	–
Thermostat	Valve opening temperature of thermostat °C	82 ± 1.5	–
	Full-opening temperature of thermostat °C	95	–
	Valve lift (at 95°C) mm	8.5 or more	–



## LUBRICANT

Items	Quantity ℓ
mitsubishi GENUINE COOLANT or equivalent	6

**SEALANTS**

Items	Specified sealant	Remarks
Cylinder block drain plug	3M Nut Locking Part No. 4171 or equivalent	Drying sealant
Water pump	Mitsubishi Genuine Parts No. MD970389 or equivalent	Semi-drying sealant
Water fitting		
Water outlet fitting		
Water by-pass fitting		

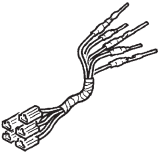
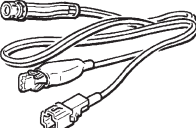
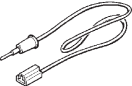
**SPECIAL TOOL**

Tool	Number	Name	Use
<p><b>A</b></p>  <p><b>B</b></p>  <p><b>C</b></p>  <p><b>D</b></p>  <p>C991223</p>	<p>MB991223</p> <p>A: MB991219 B: MB991220 C: MB991221 D: MB991222</p>	<p>Harness set</p> <p>A: Test harness B: LED harness C: LED harness adapter D: probe</p>	<p>Measurement of terminal voltage</p> <p>A: Connector pin contact pressure inspection B: Power circuit inspection C: Power circuit inspection D: Commercial tester connection</p>

**TROUBLESHOOTING****INSPECTION CHART FOR TROUBLE SYMPTOMS**

Trouble symptoms	Inspection procedure No.	Reference page
Radiator fan and condenser fan do not operate. <Vehicles with A/C> Radiator fan does not operate. <Vehicles without A/C>	1	14-4
Radiator fan and condenser fan do not change speed or stop. <Vehicles with A/C> Radiator fan does not change speed or stop. <Vehicles without A/C>	2	14-6
Radiator fan does not operate. <Vehicles with A/C>	3	14-7
Condenser fan does not operate. <Vehicles with A/C>	4	14-7

INSPECTION PROCEDURE FOR TROUBLE SYMPTOMS

Inspection Procedure 1

Radiator fan and condenser fan do not operate. <Vehicles with A/C> Radiator fan does not operate. <Vehicles without A/C>	Probable cause
The cause could be a malfunction of the fan controller power supply or earth circuit. The cause could also be a malfunction of the fan controller or the engine-ECU.	<ul style="list-style-type: none"> <li>● Malfunction of fusible link</li> <li>● Malfunction of fan control relay</li> <li>● Malfunction of fan controller</li> <li>● Malfunction of engine-ECU</li> <li>● Malfunction of wiring harness or connector</li> </ul>

<Vehicles with A/C>

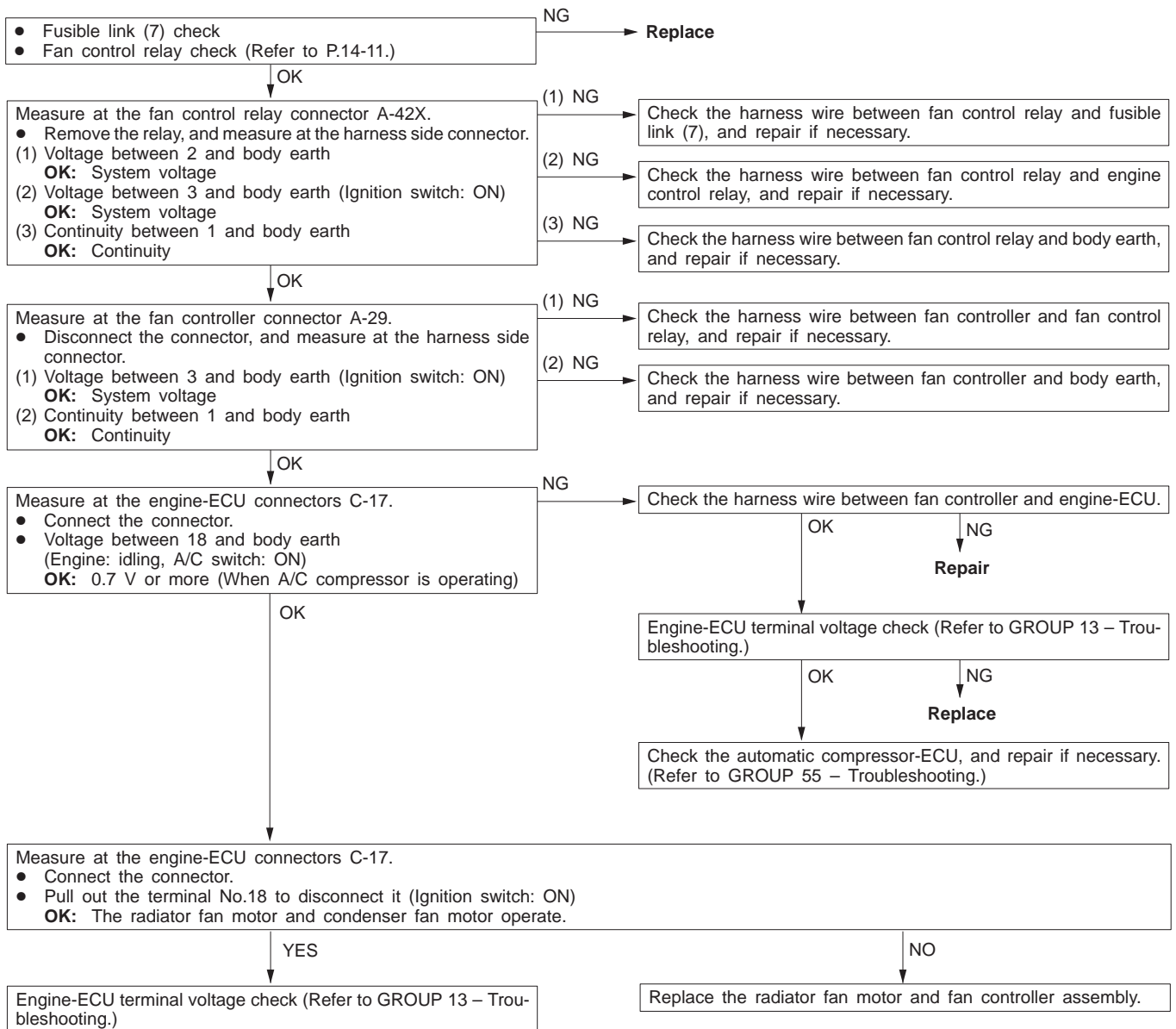

<Vehicles without A/C>

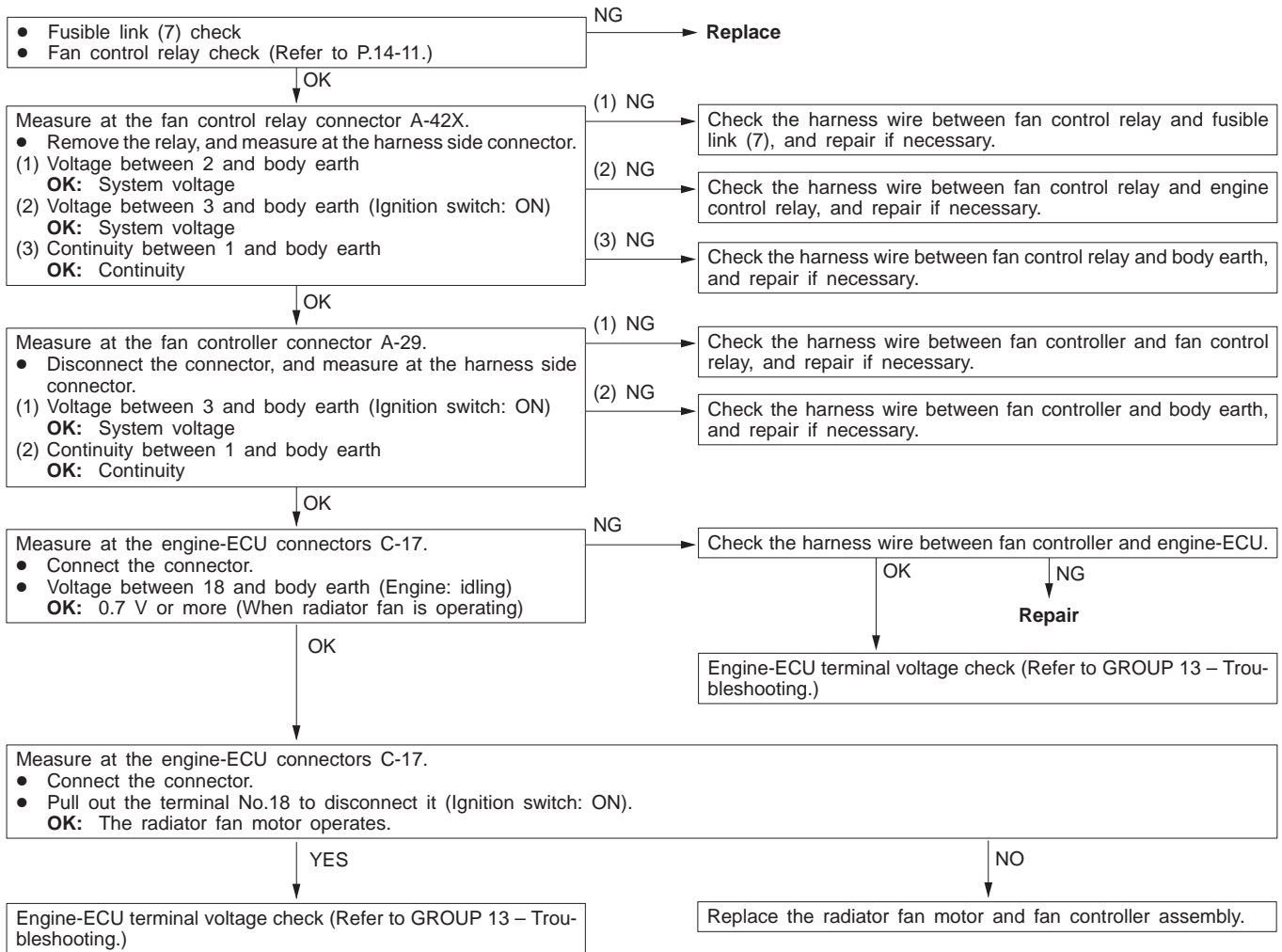

Inspection Procedure 2

<b>Radiator fan and condenser fan do not change speed or stop. &lt;Vehicles with A/C&gt;</b> <b>Radiator fan does not change speed or stop. &lt;Vehicles without A/C&gt;</b>	<b>Probable cause</b>
The fan controller carries out step-free control of the radiator fan motor and the condenser fan motor speeds using signals transmitted from the engine-ECU.	<ul style="list-style-type: none"> <li>● Malfunction of fan control relay</li> <li>● Malfunction of fan controller</li> <li>● Malfunction of engine-ECU</li> <li>● Malfunction of wiring harness or connector</li> </ul>

<Vehicles with A/C>

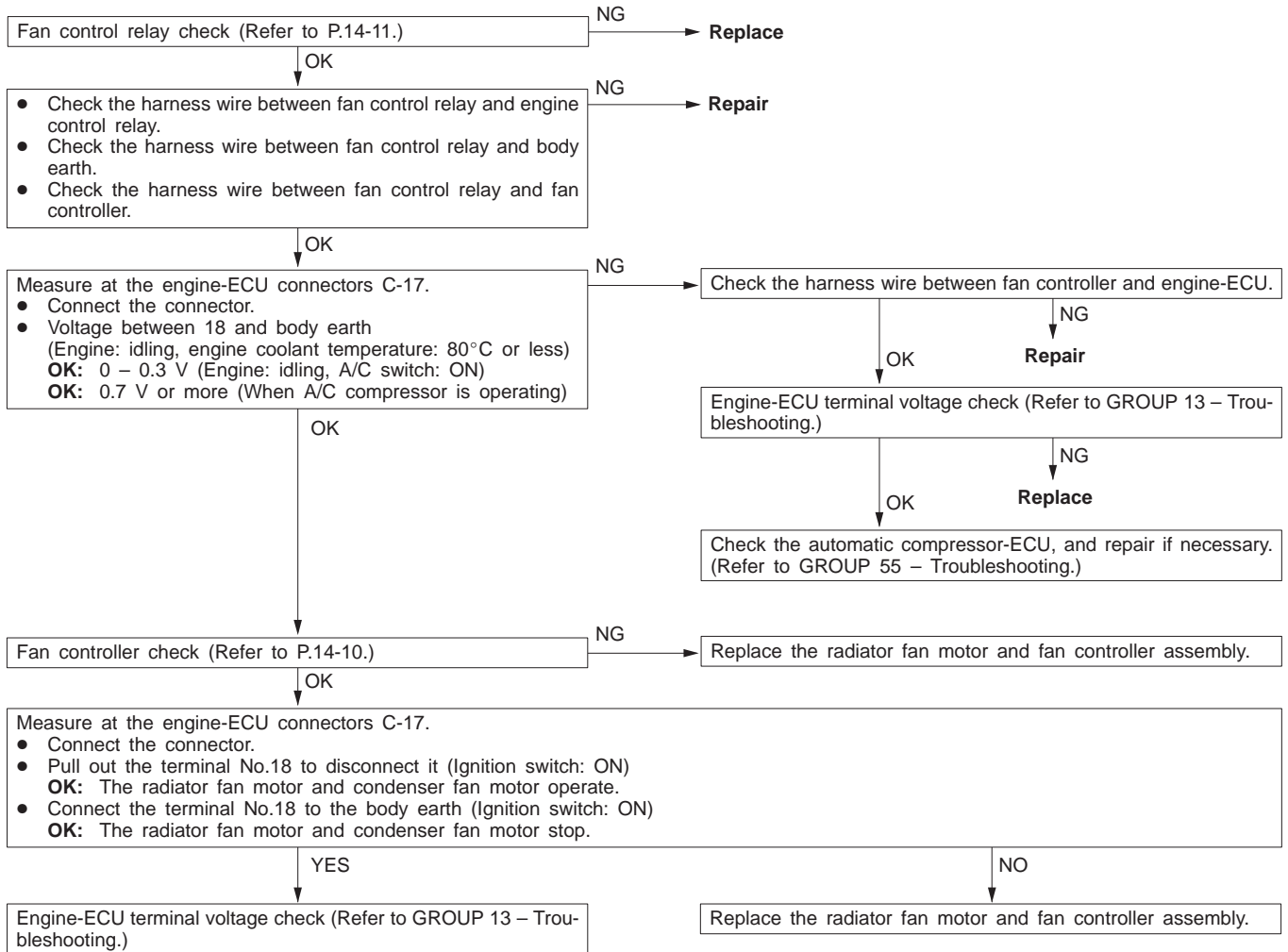

<Vehicles without A/C>

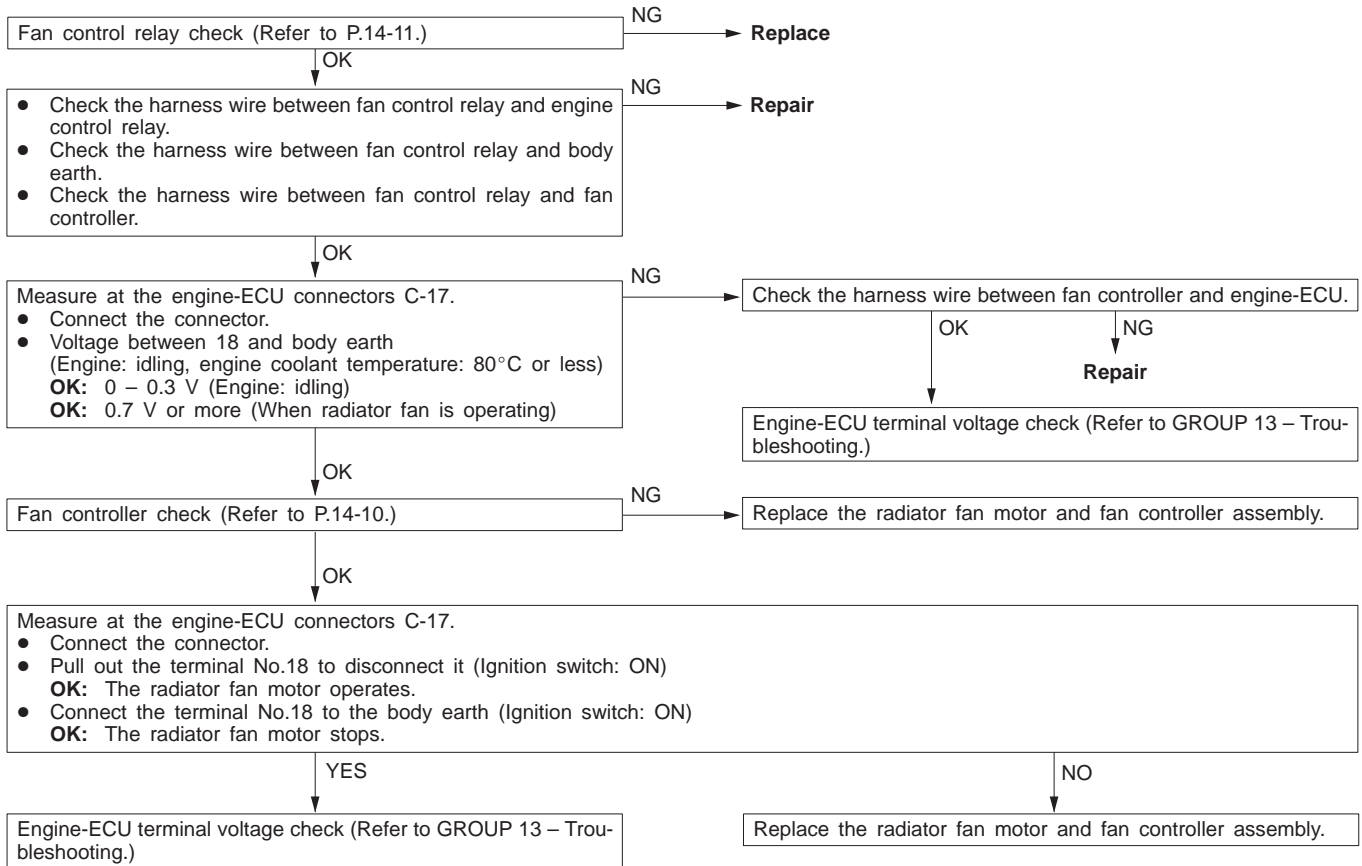

Inspection Procedure 3

Radiator fan does not operate. <Vehicles with A/C>	Probable cause
The cause could be a malfunction of the radiator fan motor or an open circuit between the fan controller and the radiator fan motor.	<ul style="list-style-type: none"> <li>Malfunction of radiator fan motor</li> <li>Open circuit between fan controller and radiator fan motor</li> </ul>

Replace the radiator fan motor and fan controller assembly.

Inspection Procedure 4

Condenser fan does not operate. <Vehicles with A/C>	Probable cause
The cause could be a malfunction of the condenser fan motor or of the fan controller.	<ul style="list-style-type: none"> <li>Malfunction of condenser fan motor</li> <li>Malfunction of fan controller</li> <li>Malfunction of wiring harness or connector</li> </ul>

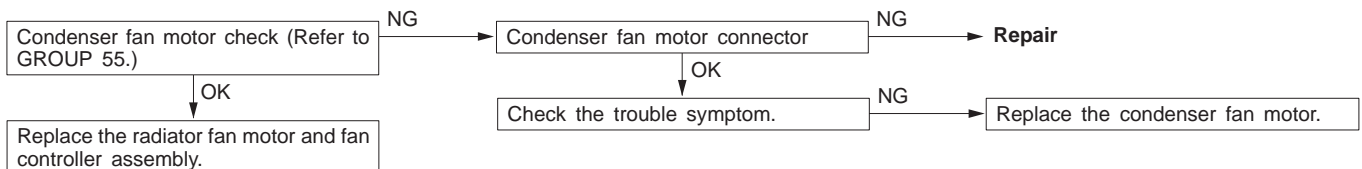



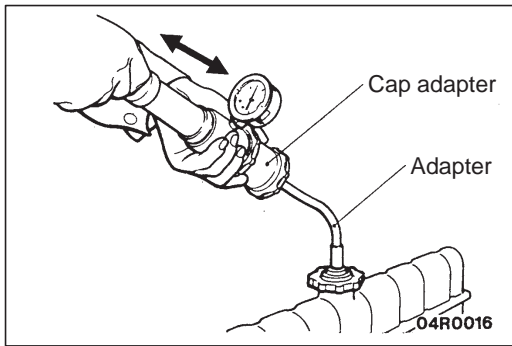

## ON-VEHICLE SERVICE

### ENGINE COOLANT LEAK CHECKING

1. Confirm that the coolant level is up to the filler neck. Install a radiator cap tester, adapter and cap adapter to the filler neck, and apply 160 kPa pressure, and then check for leakage from the radiator hose or connections.

#### Caution

- (1) Be sure to completely clean away any moisture from the places checked.
  - (2) When the tester is taken out, be careful not to spill any coolant from it.
  - (3) Be careful, when installing and removing the tester and when testing, not to deform the radiator filler neck.
2. If there is leakage, repair or replace the appropriate part.

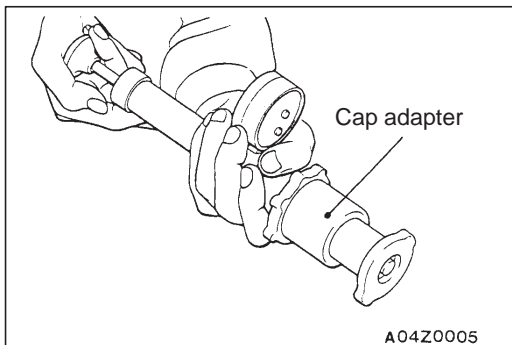

### RADIATOR CAP VALVE OPENING PRESSURE CHECK

1. Use a cap adapter to attach the cap to the radiator cap tester.
2. Increase the pressure until the indicator of the gauge stops moving.

**Standard value: 75 – 105 kPa**

**Limit: 65 kPa**

3. Replace the radiator cap if the reading does not remain at or above the limit.

#### NOTE

Be sure that the cap is clean before testing, since rust or other foreign material on the cap seal will cause an improper indication.

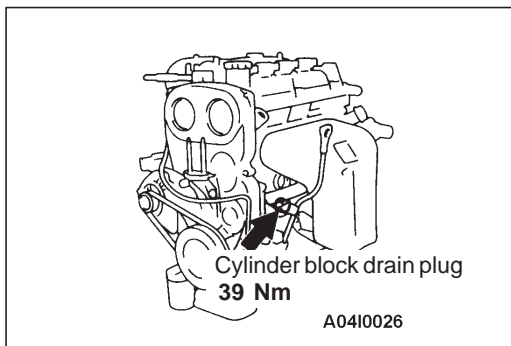

## ENGINE COOLANT REPLACEMENT

1. Drain the engine coolant by removing the drain plug and then the radiator cap.
2. Remove the drain plug from the cylinder block to drain the engine coolant.
3. Remove the reserve tank to drain the engine coolant.
4. When the engine coolant has drained, pour in water from the radiator cap to clean the engine coolant line.
5. Coat the thread of the cylinder block drain plug with the specified sealant and tighten to the specified torque.

### Specified sealant:

**3M Nut Locking Part No. 4171 or equivalent**

6. Securely tighten the radiator drain plug.
7. Install the reserve tank.
8. Slowly pour the engine coolant into the mouth of the radiator until the radiator is full, and pour also into the reserve tank up to the FULL line.

### Recommended antifreeze:

**MITSUBISHI GENUINE COOLANT or equivalent**

**Quantity: 6 ℓ**

### Caution

**Do not use alcohol or methanol anti-freeze or any engine coolants mixed with alcohol or methanol anti-freeze. The use of an improper anti-freeze can cause the corrosion of the aluminium components.**

9. Install the radiator cap securely.
10. Start the engine and warm the engine until the thermostat opens. (Touch the radiator hose with your hand to check that warm water is flowing.)
11. After the thermostat opens, race the engine several times, and then stop the engine.
12. Cool down the engine, and then pour engine coolant into the reserve tank until the level reaches the FULL line. If the level is low, repeat the operation from step 11.

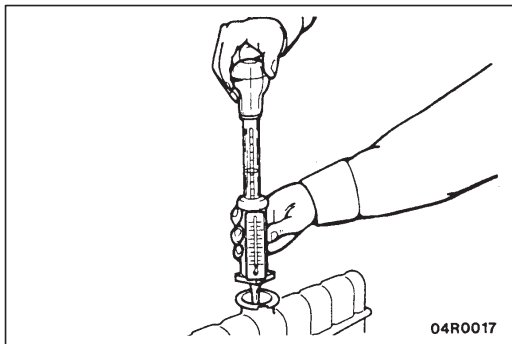

### CONCENTRATION MEASUREMENT

Measure the temperature and specific gravity of the engine coolant to check the antifreeze concentration.

**Standard value: 30–60% (allowable concentration range)**

### RECOMMENDED ANTIFREEZE

Antifreeze	Allowable concentration
MITSUBISHI GENUINE COOLANT or equivalent	30–60%

### Caution

If the concentration of the antifreeze is below 30 %, the anti-corrosion property will be adversely affected. In addition, if the concentration is above 60 %, both the anti-freezing and engine cooling properties will decrease, affecting the engine adversely. For these reasons, be sure to maintain the concentration level within the specified range.

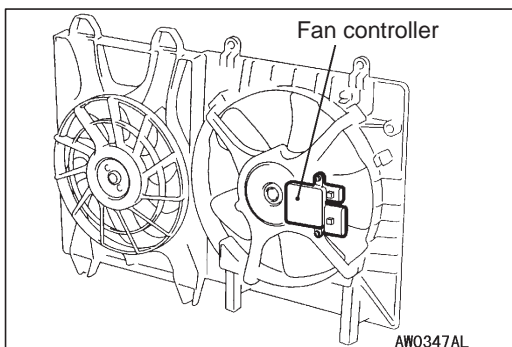

### FAN CONTROLLER CHECK

1. Disconnect the condenser fan motor connector.
2. Start the engine and run it at idle.
3. Turn the A/C switch to ON and maintain the coolant temperature at 80°C or less.
4. When measuring the voltage between the fan controller-side connector terminals, check that the value changes repeatedly as indicated by (1) – (3) below.
  - (1) 0 V
  - (2)  $8.2 \pm 2.6$  V
  - (3) Battery voltage  $\pm 2.6$  V
5. If the voltage does not repeatedly change as indicated, replace the radiator fan motor and the fan controller assembly.

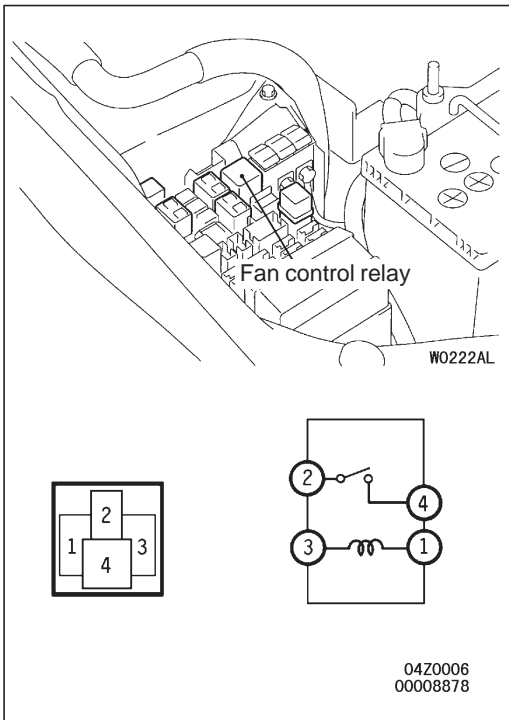

**FAN CONTROL RELAY CONTINUITY CHECK**

Battery voltage	Terminal No.			
	1	2	3	4
When current is not supplied	○		○	
When current is supplied	⊖	○	⊕	○

## THERMOSTAT

### REMOVAL AND INSTALLATION

#### Pre-removal and Post-installation Operation

- Engine Coolant Draining and Supplying  
(Refer to P.14-9.)
- Engine Cover and Under Cover Removal and Installation
- Air Cleaner Removal and Installation  
(Refer to GROUP 15.)

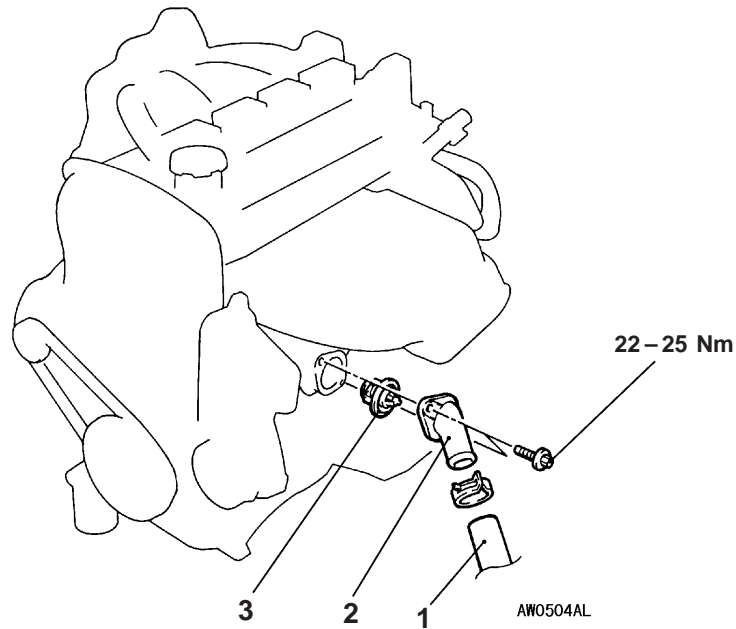

#### Removal steps

- ◀A▶ ▶B▶ 1. Radiator lower or upper hose connection
- ▶A▶ 2. Water inlet or outlet fitting
- ▶A▶ 3. Thermostat

#### REMOVAL SERVICE POINT

##### ◀A▶ RADIATOR LOWER OR UPPER HOSE DISCONNECTION

After making mating marks on the radiator hose and the hose clamp, disconnect the radiator hose.

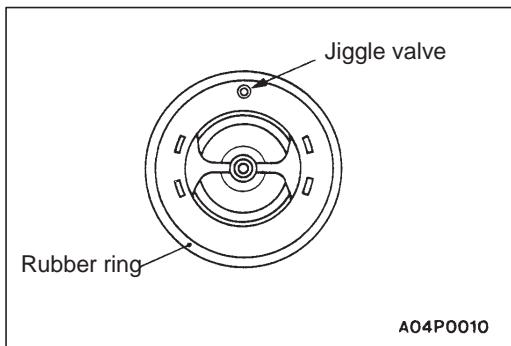

## INSTALLATION SERVICE POINTS

### ►A◄ THERMOSTAT INSTALLATION

Install the thermostat so that the jiggle valve is facing straight up.

#### Caution

**Make absolutely sure that no oil is adhering to the rubber ring of the thermostat. In addition, be careful not to fold over or scratch the rubber ring when inserting. If the rubber ring is damaged, replace the thermostat.**

### ►B◄ RADIATOR LOWER OR UPPER HOSE CONNECTION

1. Insert each hose as far as the projection of the water inlet fitting.
2. Align the mating marks on the radiator hose and hose clamp, and then connect the radiator hose.

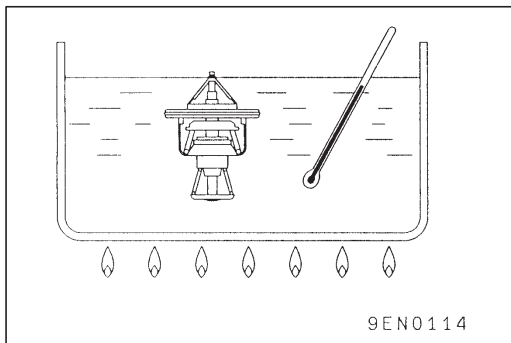

## INSPECTION

### THERMOSTAT CHECK

1. Immerse the thermostat in water, and heat the water while stirring. Check the thermostat valve opening temperature.

#### Standard value:

**Valve opening temperature:  $82 \pm 1.5^\circ\text{C}$**

2. Check that the amount of valve lift is at the standard value when the water is at the full-opening temperature.

#### Standard value:

**Full-opening temperature:  $95^\circ\text{C}$**

**Amount of valve lift: 8.5 mm or more**

#### NOTE

Measure the valve height when the thermostat is fully closed, and use this measurement to calculate the valve height when the thermostat is fully open.

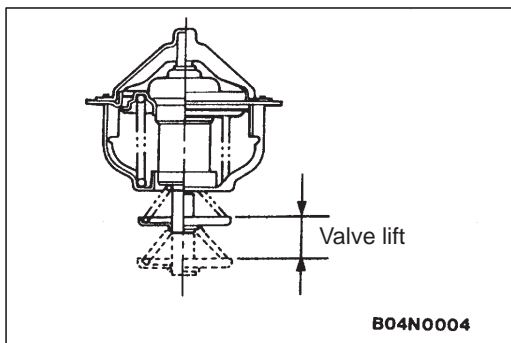

## WATER PUMP

### REMOVAL AND INSTALLATION

#### Pre-removal and Post-installation Operation

- Engine Coolant Draining and Supplying (Refer to P.14-9.)
- Timing Belt Removal and Installation (Refer to GROUP 11.)
- Idler Pulley Removal and Installation (Refer to GROUP 11A.)

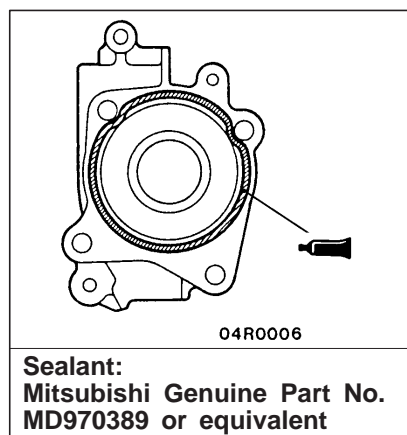
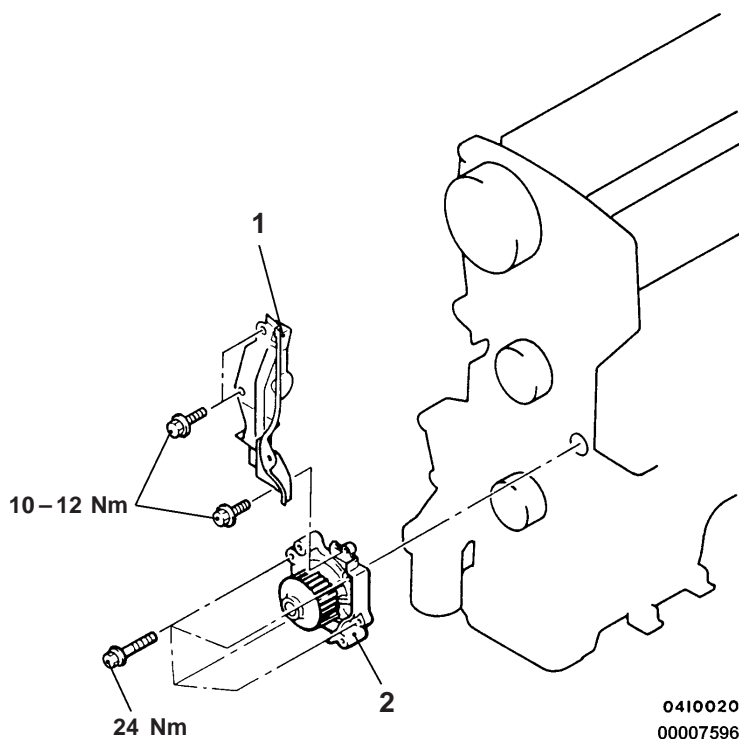

#### Removal steps

- ▶◀ 1. Timing belt rear cover  
▶◀ 2. Water pump

### INSTALLATION SERVICE POINT

#### ▶◀ WATER PUMP INSTALLATION

Squeeze out the sealant from the tube evenly and apply it so that there is not too much sealant and no places without sealant.

#### Specified Sealant:

Mitsubishi Genuine Parts No. MD970389 or equivalent

# WATER HOSE AND WATER PIPE

## REMOVAL AND INSTALLATION

**Pre-removal and Post-installation Operation**

- Engine Coolant Draining and Supplying (Refer to P.14-9.)
- Engine Cover Removal and Installation
- Air Cleaner Removal and Installation (Refer to GROUP 15.)
- Exhaust Manifold Removal and Installation (Refer to GROUP 15.)

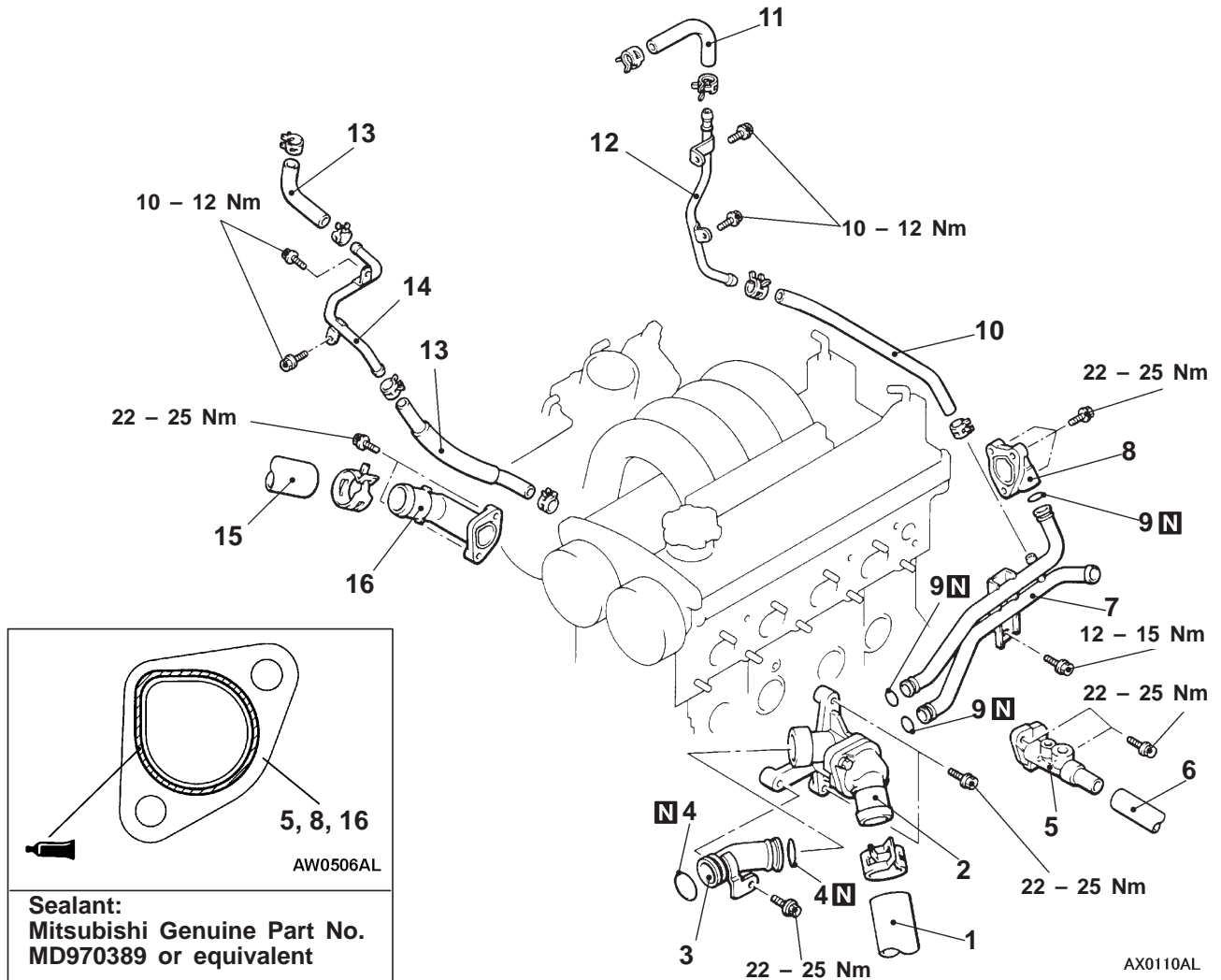

**Removal steps**

- ◀A▶ ▶B▶ 1. Radiator lower hose connection
- ▶C▶ 2. Thermostat case assembly
- ▶C▶ 3. Water pipe
- ▶C▶ 4. O-ring
- ▶C▶ 5. Water fitting
- ▶C▶ 6. Heater hose connection
- ▶A▶ ▶C▶ 7. Water pipe assembly
- ▶A▶ ▶C▶ 8. Water by-pass fitting
- ▶A▶ ▶C▶ 9. O-ring

- EGR valve (Refer to GROUP 17.)
- 10. Water hose
- 11. Water hose
- 12. Water pipe
- 13. Water hose
- 14. Water pipe
- ▶B▶ ▶A▶ 15. Radiator upper hose connection
- ▶A▶ 16. Water outlet fitting



**REMOVAL SERVICE POINT****◀A▶ RADIATOR UPPER HOSE/RADIATOR LOWER HOSE DISCONNECTION**

After making mating marks on the radiator hose and the hose clamp, disconnect the radiator hose.

**INSTALLATION SERVICE POINTS****▶A◀ WATER OUTLET FITTING/WATER BY-PASS FITTING/WATER FITTING INSTALLATION**

1. Use a gasket scraper or wire brush to eliminate completely foreign materials adhered to the gasket surface.
2. Apply the specified sealant continuously.

**Specified sealant:**

**Mitsubishi Genuine Parts No. MD970389 or equivalent**

3. Install the water fitting, water bypass fitting and the water outlet fitting while the sealant is wet (within 15 minutes after applying the sealant). Do not apply sealant to the positions other than the required.

**▶B◀ RADIATOR UPPER HOSE/RADIATOR LOWER HOSE CONNECTION**

1. Insert each hose as far as the projection of the water inlet fitting.
2. Align the mating marks on the radiator hose and hose clamp, and then connect the radiator hose.

**▶C◀ O-RING INSTALLATION**

Insert the O-ring to the water inlet pipe assembly, and coat the outer circumference of the O-ring with water or engine coolant.

**Caution**

**Do not allow engine oil or other greases to adhere to the O-ring**

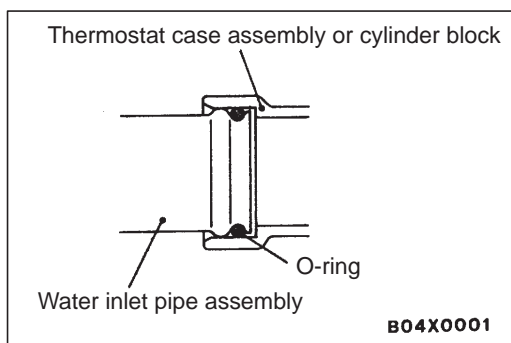

**INSPECTION**

**WATER PIPE AND HOSE CHECK**

Check the water pipe and hose for cracks, damage, clog and replace them if necessary.

# RADIATOR

## REMOVAL AND INSTALLATION

### Pre-removal Operations

- Engine Coolant Draining (Refer to P.14-9.)
- Engine Cover and Under Cover Removal
- Air Cleaner Removal (Refer to GROUP 15.)

### Post-installation Operations

- Air Cleaner Installation (Refer to GROUP 15.)
- Engine cover and Under Cover Installation
- Engine Coolant Supplying (Refer to P.14-9.)
- A/T Fluid Supplying (Refer to GROUP 23 – On-vehicle Service.)

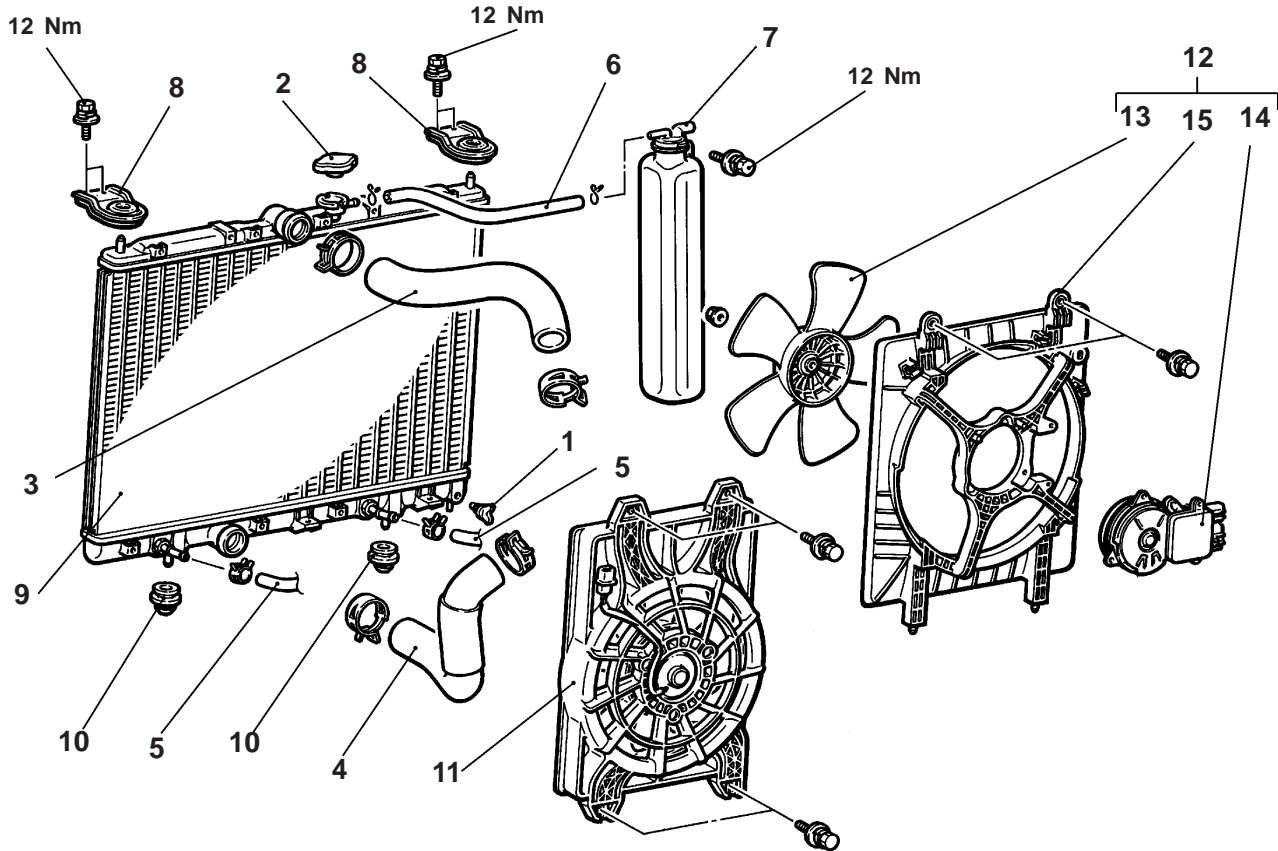

AW0261AL

### Radiator removal steps

1. Drain plug
2. Radiator cap
3. Radiator upper hose
4. Radiator lower hose
5. A/T oil cooler hose connection
6. Rubber hose
7. Condense tank
8. Upper insulator
9. Radiator assembly
10. Lower insulator
11. Condenser fan motor assembly
12. Radiator fan motor assembly



### Radiator fan motor, fan controller assembly removal steps

12. Radiator fan motor assembly
13. Fan
14. Radiator fan motor and fan controller assembly
15. Shroud

**REMOVAL SERVICE POINTS****◀A▶ RADIATOR UPPER HOSE/RADIATOR LOWER HOSE DISCONNECTION**

After making mating marks on the radiator hose and the hose clamp, disconnect the radiator hose.

**◀B▶ A/T OIL COOLER HOSE REMOVAL**

After removing the hose from the radiator, plug the hose and the radiator nipple to prevent dust or foreign particles from getting in.

**INSTALLATION SERVICE POINT****▶A◀ RADIATOR LOWER HOSE/RADIATOR UPPER HOSE CONNECTION**

1. Insert each hose as far as the projection of the water inlet fitting.
2. Align the mating marks on the radiator hose and hose clamp, and then connect the radiator hose.

---

## NOTES

## GROUP 14

# ENGINE COOLING

### GENERAL

#### OUTLINE OF CHANGES

The following service procedures have been established due to the addition of vehicles with 4G9-MPI engine. Other service procedures are the same as the vehicles with GDI engine.

### WATER HOSE AND WATER PIPE

#### REMOVAL AND INSTALLATION

##### Pre-removal and Post-installation Operation

- Engine Coolant Draining and Suppling
- Air Cleaner Removal and Installation (Refer to GROUP 15.)
- Exhaust Manifold Removal and Installation (Refer to GROUP 15.)

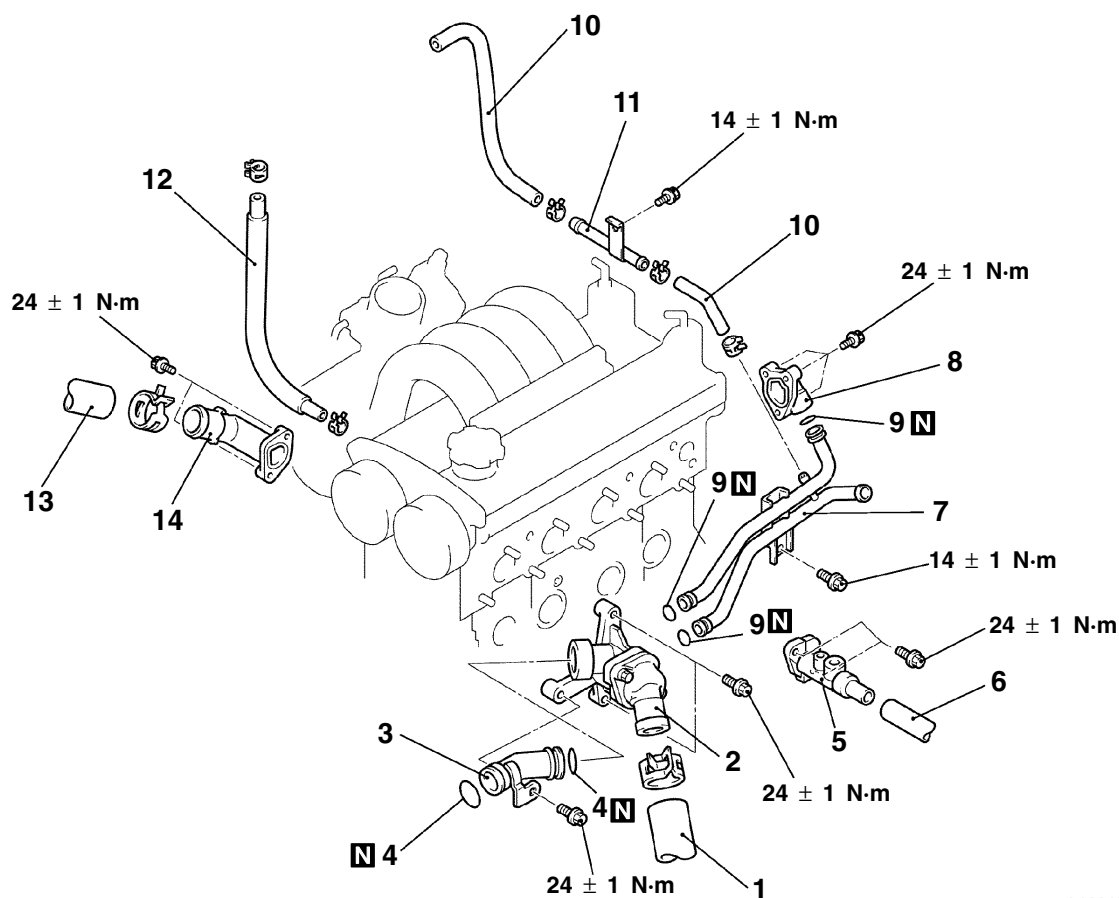

A10015AL

#### Removal steps

1. Radiator lower hose connection
2. Thermostat case assembly
3. Water pipe
4. O-ring
5. Water fitting
6. Heater hose connection
7. Water pipe assembly
8. Water by-pass fitting
9. O-ring
10. Water hose
11. Water pipe
12. Water hose
13. Radiator upper hose connection
14. Water outlet fitting

**RADIATOR****REMOVAL AND INSTALLATION****Pre-removal Operations**

- Engine Coolant Draining
- Engine Cover and Under Cover Removal
- Air Cleaner Removal

**Post-installation Operations**

- Air Cleaner Installation
- Engine Cover and Under Cover Installation
- Engine Coolant Supplying
- A/T Fluid Supplying

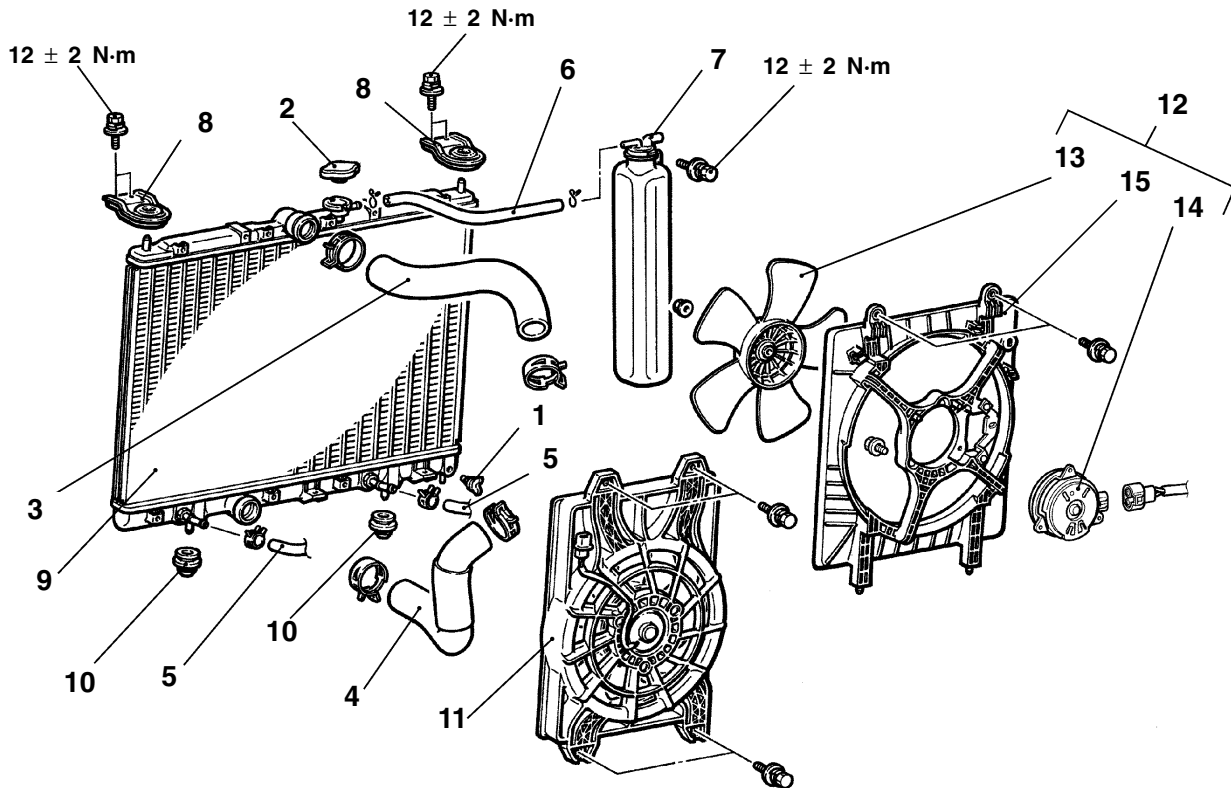

AC103718AB

**Radiator removal steps**

1. Drain plug
2. Radiator cap
3. Radiator upper hose
4. Radiator lower hose
5. A/T oil cooler hose connection
6. Rubber hose
7. Condense tank
8. Upper insulator
9. Radiator assembly
10. Lower insulator
11. Condenser fan motor assembly
12. Radiator fan motor assembly

**Radiator fan motor assembly removal steps**

12. Radiator fan motor assembly
13. Fan
14. Radiator fan motor
15. Shroud

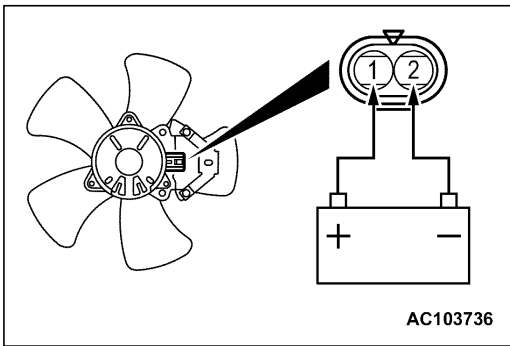

**INSPECTION**

**RADIATOR FAN MOTOR CHECK**

1. Check to be sure that the radiator fan rotates when battery voltage is applied between terminals (as shown in the figure).
2. Check to see that abnormal noises are not produced, while motor is turning.

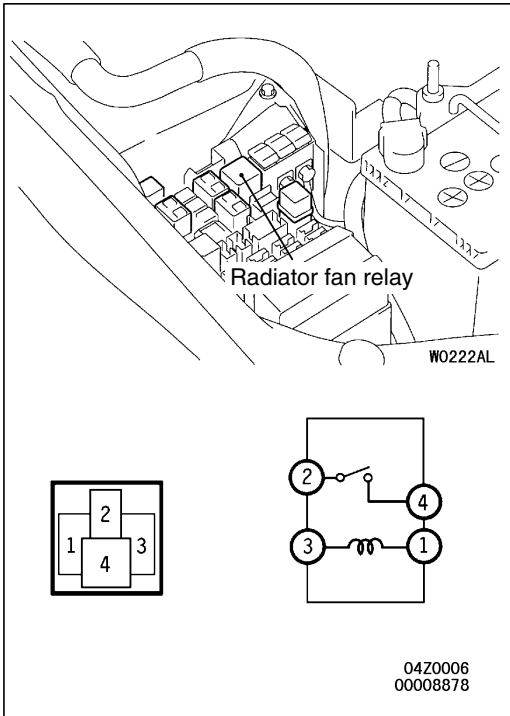

**RADIATOR FAN RELAY CONTINUITY CHECK**

Battery voltage	Terminal No.			
	1	2	3	4
When current is not supplied	○		○	
When current is supplied	⊖		⊕	



---

## NOTES