<4D5> ENGINE

ENGINE <4D5>

CONTENTS

11109000405

GENERAL INFORMATION	2	Timing Belt Tension Adjustment	14
SERVICE SPECIFICATIONS	3	Timing Belt "B" Tension Adjustment	15
SEALANTS	3	CRANKSHAFT PULLEY	17
SPECIAL TOOLS	4	CAMSHAFT AND CAMSHAFT OIL SEAL ...	18
ON-VEHICLE SERVICE	5	OIL PAN AND OIL SCREEN	21
Drive Belt Tension Check and Adjustment	5	CYLINDER HEAD GASKET	23
Valve Clearance Check and Adjustment	8	TIMING BELT AND TIMING BELT B	26
Injection Timing Check and Adjustment	9	CRANKSHAFT FRONT OIL SEAL	30
Idle Speed Check and Adjustment	11	CRANKSHAFT REAR OIL SEAL	31
Idle-up Mechanism Check and Adjustment-For A/C	11	ENGINE ASSEMBLY	33
Idle-up Mechanism Check and Adjustment-For ABS	11		
Compression Pressure Check	13		

GENERAL INFORMATION

11100010339

Items	4D56	
Total displacement mℓ	2,477	
Bore x Stroke mm	91.1 x 95.0	
Compression ratio	21	
Combustion chamber	Vortex chamber type	
Camshaft arrangement	SOHC	
Number of valve	Intake	4
	Exhaust	4
Valve timing	Intake	Opening BTDC 20°, Closing ABDC 49°
	Exhaust	Opening BBDC 55°, Closing ATDC 22°
Fuel system	Distribution type injection pump	
Rocker arm	Roller type	
Adjusting screw	Elephant foot type	

SERVICE SPECIFICATIONS

11100030359

Items			Standard value	Limit
Alternator drive belt tension (for each belt)	Tension N	When checked	245 – 441	–
		When a used belt is installed	294 – 392	–
		When a new belt is installed	392 – 588	–
	Deflection (Reference value) mm	When checked	12.0 – 17.0	–
		When a used belt is installed	13.0 – 16.0	–
		When a new belt is installed	10.0 – 13.0	–
Power steering oil pump drive belt tension	Tension N	When checked	294 – 490	–
		When a used belt is installed	343 – 441	–
		When a new belt is installed	490 – 686	–
	Deflection (Reference value) mm	When checked	8.0 – 12.0	–
		When a used belt is installed	9.0 – 11.5	–
		When a new belt is installed	6.0 – 8.0	–
A/C compressor drive belt tension	Tension N	When checked	320 – 400	–
		When a used belt is installed	320 – 400	–
		When a new belt is installed	480 – 560	–
	Deflection (Reference value) mm	When checked	6.0 – 7.0	–
		When a used belt is installed	6.0 – 7.0	–
		When a new belt is installed	4.5 – 5.5	–
Valve clearance (at hot) mm			0.25	–
Injection timing (Value indicated on dial gauge mm)			9° ATDC (1 ± 0.03)	–
Idle speed r/min			750 ± 100	–
Idle up engine speed for ABS r/min			1,900 ± 100	–
Compression pressure kPa			3,040	Min. 2,200
Compression pressure difference of all cylinder (at engine speed of 280 r/min) kPa			–	Max. 300
Timing belt tension mm			4 – 5	–
Timing belt B tension mm			4 – 5	–





SEALANTS

11100050270

Items	Specified sealant	Remarks
Oil pan	MITSUBISHI GENUINE PART MD970389 or equivalent	Semi-drying sealant
Semi-circular packing and rocker cover seal, and cylinder head seal	3M ATD Part No. 8660 or equivalent	

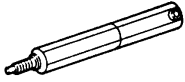
SPECIAL TOOLS

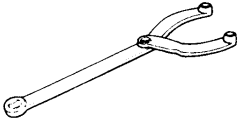
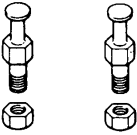
11100060327

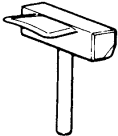
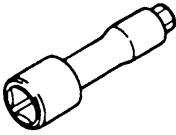
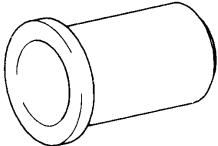
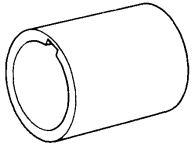
Tool	Number	Name	Use
	MD998384	Prestroke measuring adapter	Adjustment of the injection timing
	MD998721	Crankshaft pulley holder	Holding the crankshaft pulley
	MB990767	End yoke holder	Holding the camshaft sprocket
	MD998719	Crankshaft pulley holder pin	
	MD998381	Camshaft oil seal installer	Installing the camshaft oil seal
	MD998727	Oil pan remover	Removal of oil pan
	MD998051	Cylinder head bolt wrench	Removal and installation of the cylinder head bolt
	MD998382	Crankshaft front oil seal installer	Installing the crankshaft front oil seal
	MD998383	Crankshaft front oil seal guide	

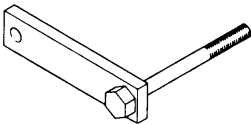
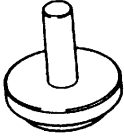
Tool	Number	Name	Use
	MD998781	Flywheel stopper	Securing the flywheel
	MD998376	Crankshaft rear oil seal installer	Press-fitting the crankshaft rear oil seal

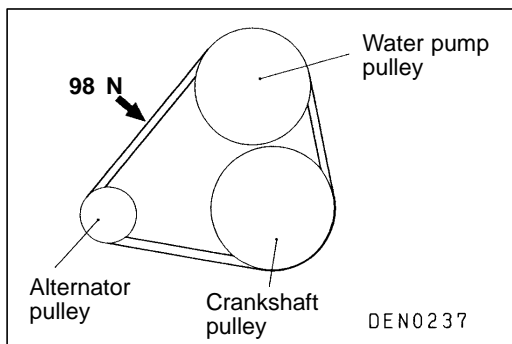

ON-VEHICLE SERVICE

11100090333

DRIVE BELT TENSION CHECK AND ADJUSTMENT

ALTERNATOR DRIVE BELT TENSION CHECK

Use a belt tension gauge to check that the belt tension is at the standard value at a point half-way between the two pulleys as shown in the illustration. In addition, press this section with a force of 98 N and check that the amount of belt deflection is at the standard value.

Standard value (for each belt):

Tension N	245 – 441
Deflection (Reference value) mm	12.0 – 17.0

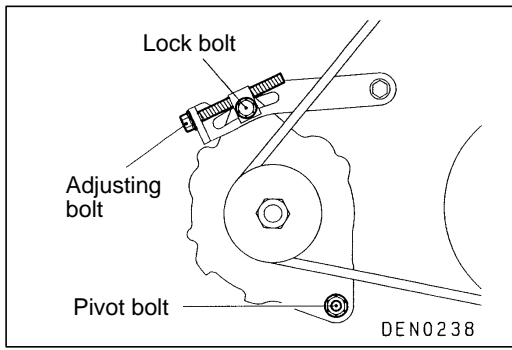

ALTERNATOR DRIVE BELT TENSION ADJUSTMENT

1. Loosen the nut of the alternator pivot bolt.
2. Loosen the lock bolt.
3. Use the adjusting bolt to adjust the belt tension and belt deflection to the standard values.

Standard value (for each belt):

Items	When a used belt is installed	When a new belt is installed
Tension N	294 – 392	392 – 588
Deflection (Reference value) mm	13.0 – 16.0	10.0 – 13.0

4. Tighten the nut of the alternator pivot bolt.

Tightening torque: 44 Nm

5. Tighten the lock bolt.

Tightening torque: 22 Nm

6. Tighten the adjusting bolt.

Tightening torque: 9.8 Nm

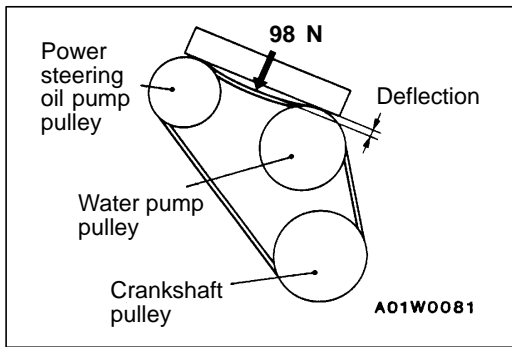

POWER STEERING OIL PUMP DRIVE BELT TENSION CHECK AND ADJUSTMENT

11100110152

1. Use a belt tension gauge to check that the belt tension is at the standard value at a point half-way between the two pulleys (indicated by an arrow in the illustration). In addition, press this section with a force of 98 N and check that the amount of belt deflection is at the standard value.

Standard value:

Items	When checked	When a used belt is installed	When a new belt is installed
Tension N	294 – 490	343 – 441	490 – 686
Deflection (Reference value) mm	8.0 – 12.0	9.0 – 11.5	6.0 – 8.0

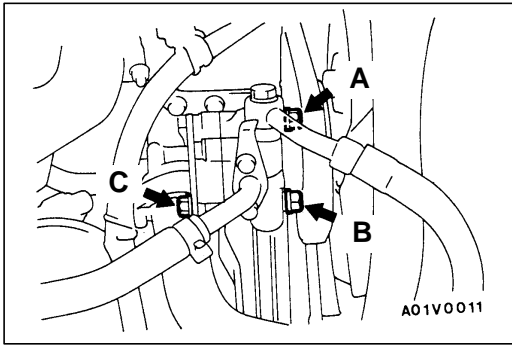

2. If the tension or deflection is outside the standard value, adjust by the following procedure.
 - (1) Loosen power steering oil pump fixing bolts A, B and C.
 - (2) Adjust the amount of belt deflection using adjusting bolt D.
 - (3) Tighten fixing bolts A, B and C.

Tightening torque: 22 Nm

- (4) Check the belt deflection amount and tension, and readjust if necessary.

Caution

Check after turning the crankshaft once or more clockwise (right turn).

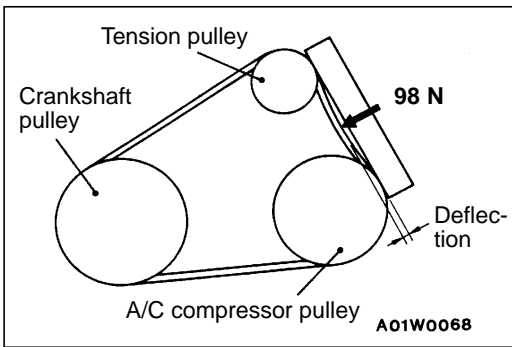

AIR CONDITIONER COMPRESSOR DRIVE BELT TENSION CHECK AND ADJUSTMENT

11100100142

1. Use a belt tension gauge to check that the belt tension is at the standard value at a point half-way between the two pulleys (indicated by an arrow in the illustration). In addition, press this section with a force of 98 N and check that the amount of belt deflection is at the standard value.

Standard value:

Items	When checked	When a used belt is intalled	When a new belt is installed
Tension N	320 – 400	320 – 400	480 – 560
Deflection (Reference value) mm	6.0 – 7.0	6.0 – 7.0	4.5 – 5.5

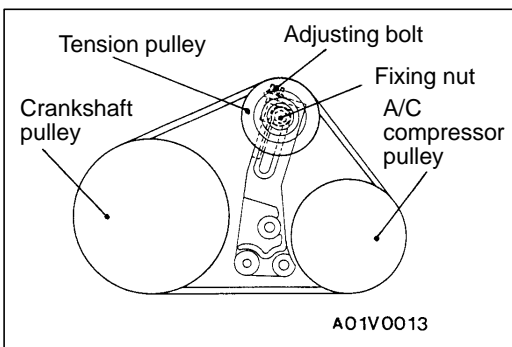

2. If the tension or deflection is outside the standard value, adjust by the following procedure.
 - (1) Loosen tension pulley fixing nut.
 - (2) Adjust belt tension with adjusting bolt.
 - (3) Tighten fixing nut.

- (4) Check the belt deflection amount and tension, and readjust if necessary.

Caution

Check after turning the crankshaft once or more clockwise (right turn).

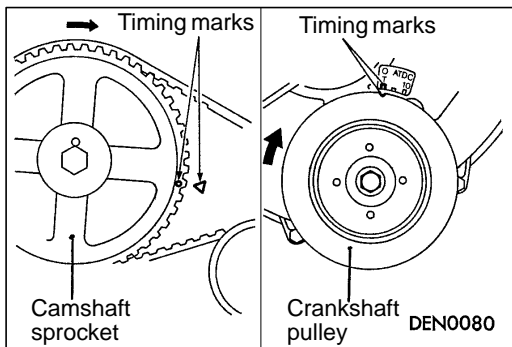
**VALVE CLEARANCE CHECK AND ADJUSTMENT**

11100150109

1. Start the engine and allow it to warm up until the engine coolant temperature reaches 80 to 90 °C.
2. Remove the timing belt upper cover.
3. Remove the rocker cover.
4. Align the camshaft sprocket timing marks and set the No. 1 cylinder at top dead centre.

Caution

The crankshaft should always be turned in a clockwise direction.

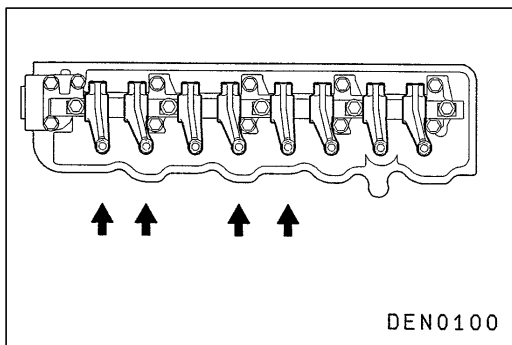

5. Measure the valve clearance at the places indicated by arrows in the illustration.

Standard value: 0.25 mm

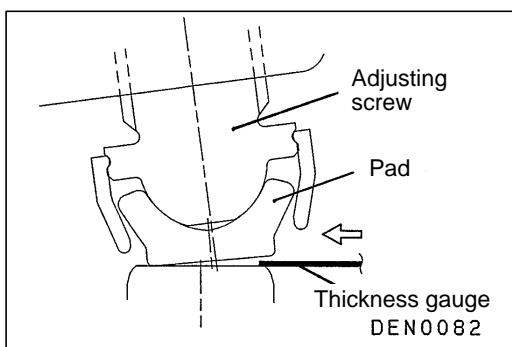
**NOTE**

Insert the thickness gauge from the centre of the cylinder head towards the outside so that it doesn't touch the pad.

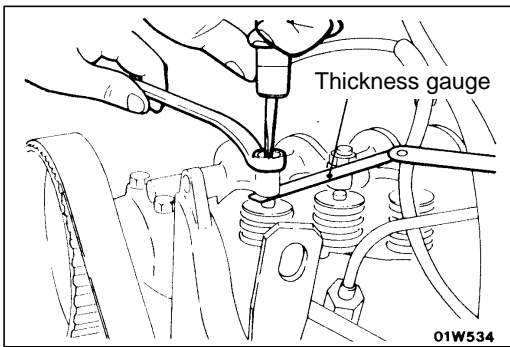

6. If the clearance is outside the standard value, loosen the lock nut of the rocker arm and adjust by turning the adjusting screw while using a thickness gauge to measure the clearance.
7. Tighten the lock nut while holding the adjusting screw with a screwdriver so that it doesn't turn.
8. Turn the crankshaft 360° clockwise to bring No. 4 cylinder to the top dead centre position.

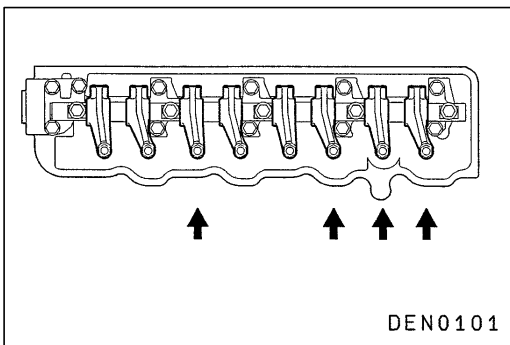

9. Measure the valve clearances at the places indicated by arrows in the illustration. If the clearance is not within the standard value, repeat steps 7 and 8 above.

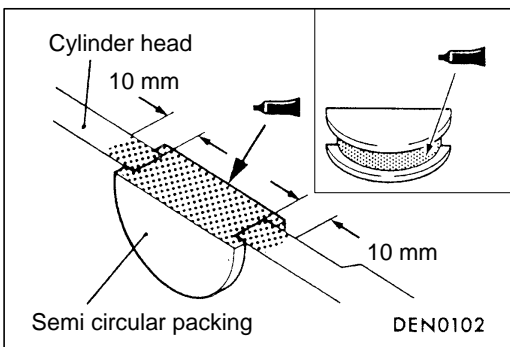

10. Apply specified sealant to the section of the semi-circular packing shown in the illustration.

Specified sealant: 3M ATD Part No. 8660 or equivalent

11. Install the rocker cover.
12. Install the timing belt upper cover.

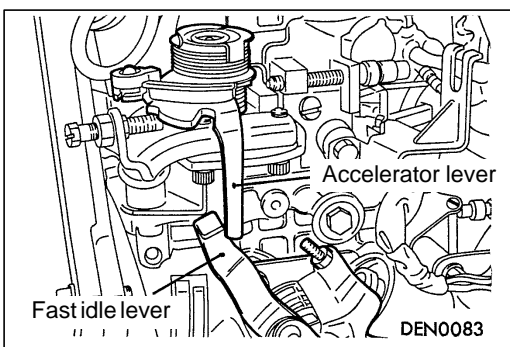

INJECTION TIMING CHECK AND ADJUSTMENT

11100180023

1. Warm up the engine and then check to be sure that the fast idle lever is separated from the throttle lever.
2. Remove all of the glow plugs.
3. Remove the timing belt upper cover.

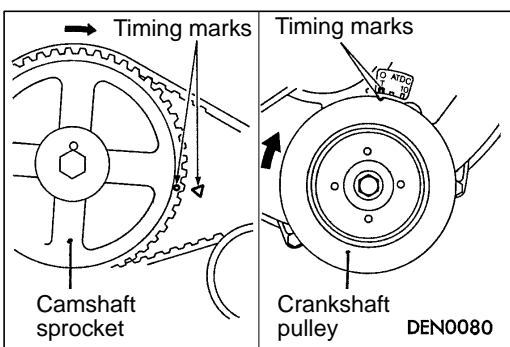

4. Align the timing marks of the camshaft sprocket and set the No. 1 cylinder to the top dead centre position.

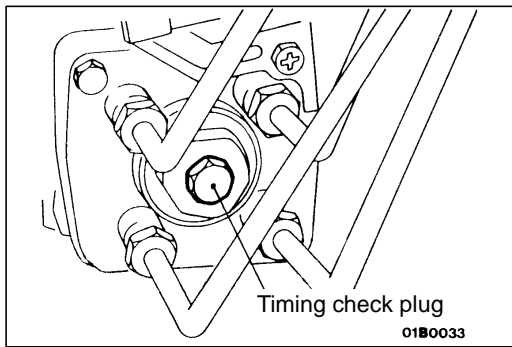

- Remove the timing check plug at the rear of the injection pump.

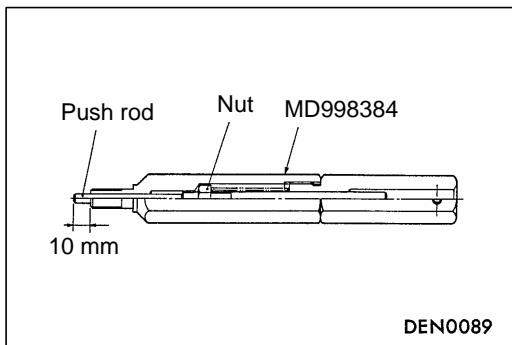

- Before installation of special tool, make sure that push rod is protruding by 10 mm. Protrusion of push rod can be adjusted with an inner nut.
- Connect the dial gauge to the special tool.

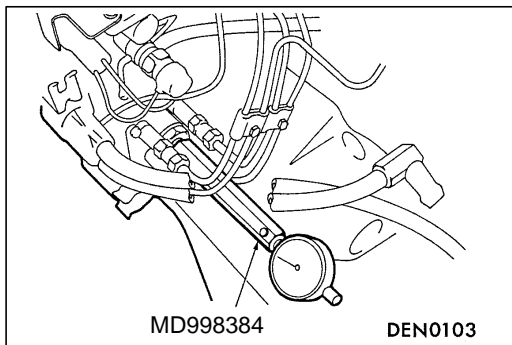

- Install the special tool to the check plug at the rear of the injection pump.

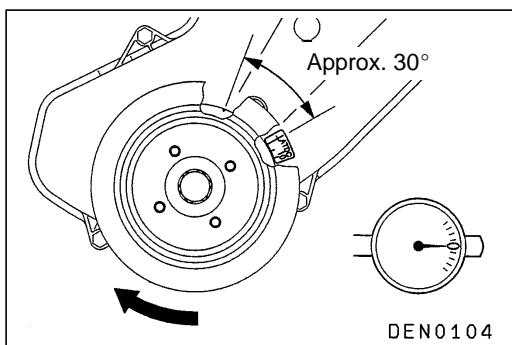

- Turn the crankshaft clockwise to move the No. 1 cylinder approximately 30° before compression top dead centre.
- Set the needle of the dial gauge to 0.
- Check that the needle doesn't move even if the crankshaft is turned slightly (2 – 3°) in both clockwise and anti-clockwise direction.

NOTE

If the needle moves, the notch is not positioned properly, so once again move the No. 1 cylinder approximately 30° before compression top dead centre.

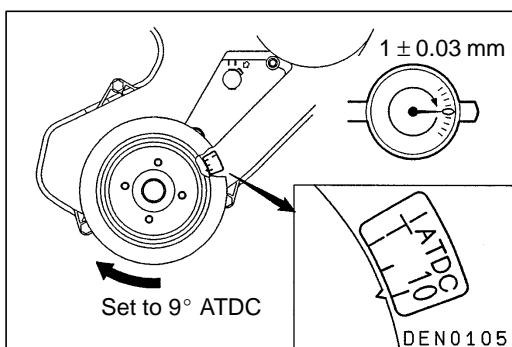

- Turn the crankshaft clockwise to align the No. 1 cylinder to 9° ATDC.
- Check that the value indicated on the dial gauge is at the standard value.

Standard value: 1 ± 0.03 mm

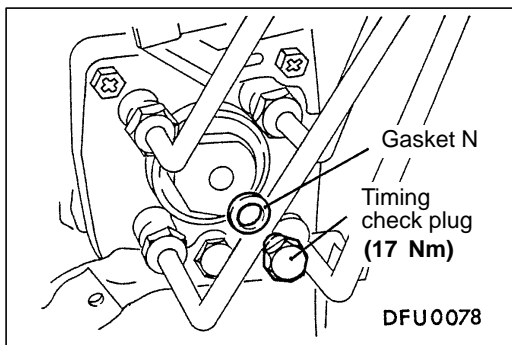
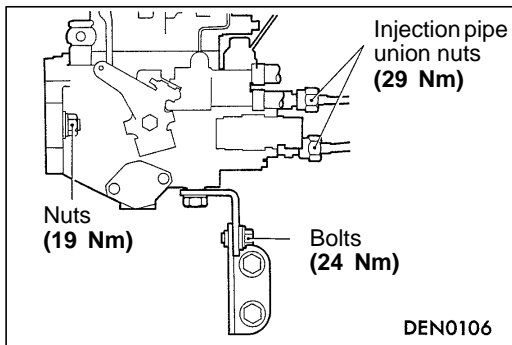
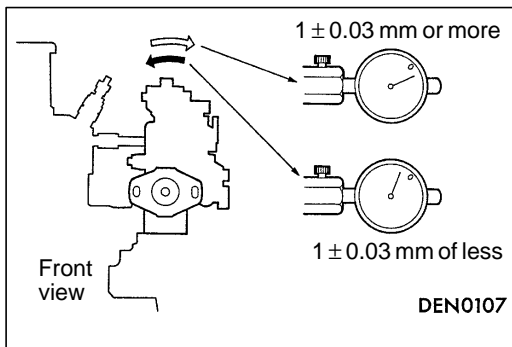
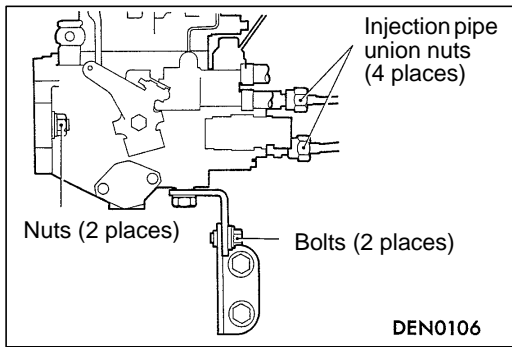

14. If the needle is outside the standard value, adjust the injection timing by the following procedure.

- (1) Loosen the injection pipe union nuts (4 places) on the injection pump. (Do not remove the union nuts.)

Caution

When loosening the nuts, hold the delivery valve holders with a spanner so that they don't turn at the same time.

- (2) Loosen the upper mounting nuts and the lower mounting bolts of the injection pump. (Do not remove the nut and bolt.)
- (3) Tilt the injection pump to the left and right and adjust the needle on the dial gauge so that the display value is uniform.
- (4) Provisionally tighten the mounting nut and bolt of the injection pump.
- (5) Repeat steps 9 – 13 to check if the adjustment has been made correctly.

- (6) Tighten the mounting nuts and bolts to the specified torque.

- (7) Tighten the injection pump union nuts to the specified torque.

Caution

When tightening the nuts, hold the delivery valve holders with a spanner so that they don't turn at the same time.

15. Remove the special tool.

16. Install a new gasket to the timing check plug.

17. Tighten the timing check plug to the specified torque.

IDLE SPEED CHECK AND ADJUSTMENT

11100190347

NOTE

Check that the injection timing is normal

1. Before inspection, set the vehicle to the pre-inspection condition.

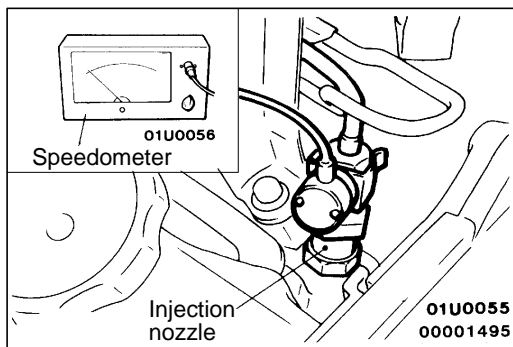

2. Connect the speedometer to the injection nozzle or the injection pipe.

Caution

When the speedometer is connected to the injection pipe, the pipe mounting clamps should all be removed.

3. Start the engine and run it at idle.
4. Check the idle speed.

Standard value: 750 ± 100 r/min

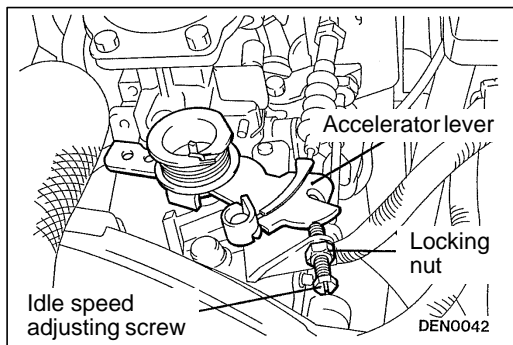

5. If not within the standard value, loosen idle adjusting screw lock nut and adjust the idle speed by rotating adjusting screw. And tighten locking nut.

IDLE-UP MECHANISM CHECK AND ADJUSTMENT-FOR A/C

11100230032

Refer to GROUP 55 – On-vehicle Service.

IDLE-UP MECHANISM CHECK AND ADJUSTMENT-FOR ABS

11100230025

1. Before inspection, set the vehicle to the pre-inspection condition.

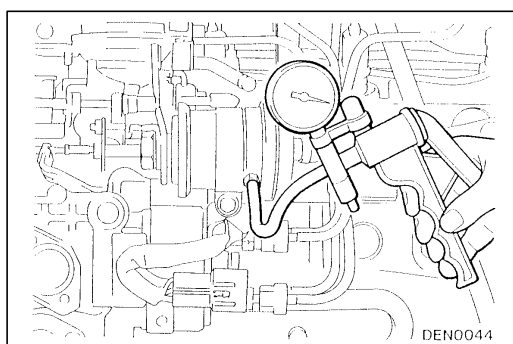

2. Inspect and adjust the idle speed.
3. Disconnect the vacuum hose (for anti-skid brakes: blue stripe) from the idle-up actuator.
4. Connect a hand vacuum pump to the nipple of the removed vacuum hose.
5. Connect the speedometer.
6. Start the engine and run it at idle.

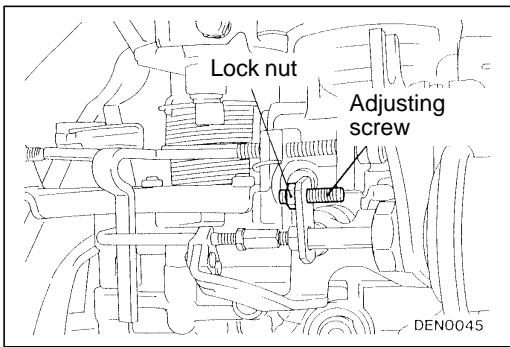

7. Check the engine speed when a negative pressure of 87 kPa is applied.

Standard value: 1,900 ± 100 r/min

8. If the engine speed is outside the standard value, loosen the lock nut on the actuator rod and adjust by turning the adjusting screw.
9. Tighten the lock nut while making sure that the adjusting screw doesn't turn.

COMPRESSION PRESSURE CHECK

11100260369

1. Before inspection, check that the engine oil, starter and battery are normal. In addition, set the vehicle to the pre-inspection condition.
2. Remove all of the glow plugs.

Caution

Be careful not to subject the glow plugs to any shocks.

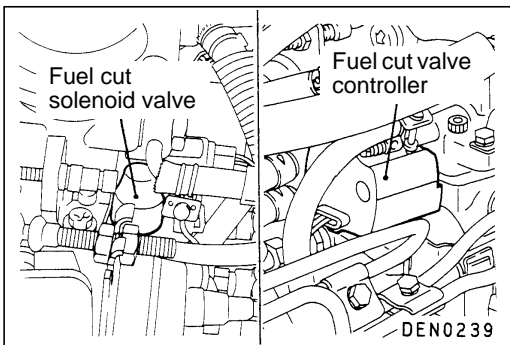

3. Disconnect the fuel cut solenoid valve connector or fuel cut valve controller.

NOTE

Doing this will prevent carrying out fuel injection.

4. Cover the glow plug hole with a shop towel etc., and after the engine has been cranked, check that no foreign material is adhering to the shop towel.

Caution

1. **Keep away from the glow plug hole when cranking**
2. **If compression is measured with water, oil, fuel, etc., that has come from cracks inside the cylinder, these materials will become heated and will gush out from glow plug hole, which is dangerous.**

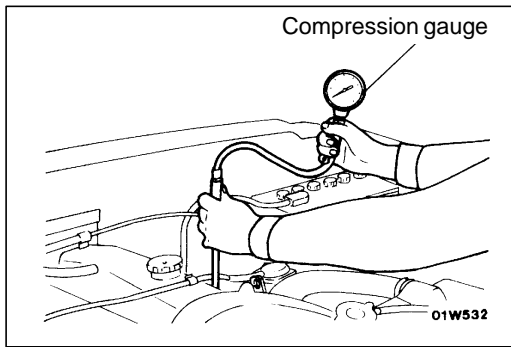

5. Set compression gauge to one of the glow plug holes.
6. Crank the engine and measure the compression pressure.

Standard value (at engine speed of 280 r/min):
3,040 kPa

Limit (at engine speed of 280 r/min): min. 2,200 kPa

7. Measure the compression pressure for all the cylinders, and check that the pressure differences of the cylinders are below the limit.

Limit: max 300 kPa

8. If there is a cylinder with compression or a compression difference that is outside the limit, pour a small amount of engine oil through the glow plug hole, and repeat the operations in steps (6) and (7).
 - (1) If the compression increases after oil is added, the cause of the malfunction is a worn or damaged piston ring and/or cylinder inner surface.
 - (2) If the compression does not rise after oil is added, the cause is a burnt or defective valve seat, or pressure is leaking from the gasket.
9. Connect the fuel cut solenoid valve connector or fuel cut valve controller connector.
10. Install the glow plugs.

Tightening torque: 18 Nm

TIMING BELT TENSION ADJUSTMENT 11100280136

1. Remove timing belt upper cover.
2. Turn the crankshaft in the clockwise direction and check the timing belt around its entire circumference for abnormalities.

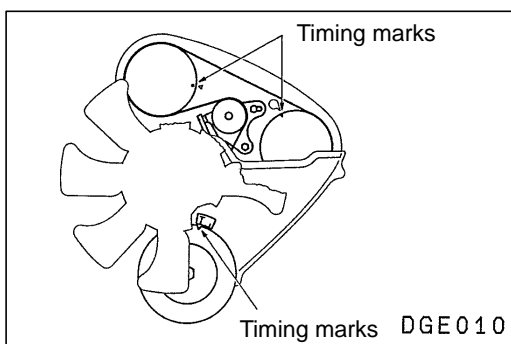

3. Align the timing marks on the sprockets with the timing marks on the front upper case.

Caution

When aligning the timing mark, be sure not to turn the crankshaft in the counterclockwise direction as this can cause improper belt tension.

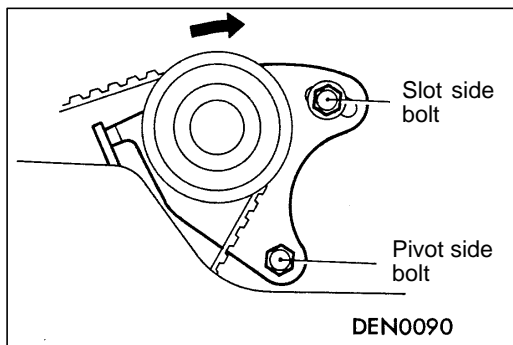

- Loosen the tensioner pivot side bolt 1 turn and slot side bolt 1 or 2 turns.

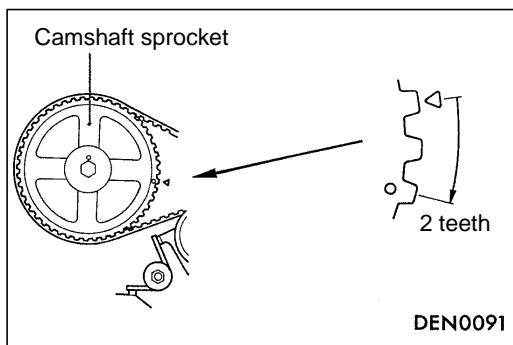

- Turn the crankshaft clockwise and stop at the second lobe of the camshaft sprocket.
- First tighten tensioner slot side bolt, and then tighten pivot side bolt to the specified torque.

Tightening torque: 25 Nm

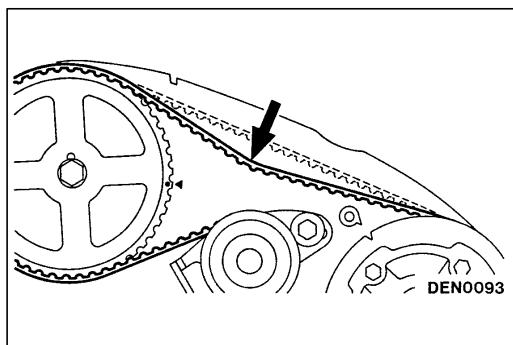

- Turn the crankshaft anti-clockwise to align the timing marks.
- Push down belt at a point halfway with a forefinger to check that tension of belt is up to standard value.

Standard value: 4 – 5 mm

- Mount the timing belt upper cover.

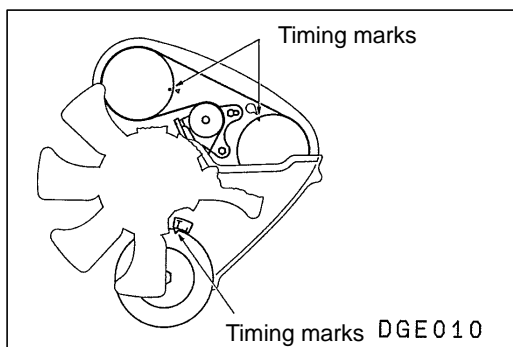

TIMING BELT “B” TENSION ADJUSTMENT

11100280143

- Remove timing belt upper cover.
- Turn the crankshaft in the clockwise direction and check the timing belt around its entire circumference for abnormalities.
- Align the timing marks on the sprockets with the timing mark on the front upper case.

Caution

When aligning the timing mark, be sure not to turn the crankshaft in the counterclockwise direction as this can cause improper belt tension.

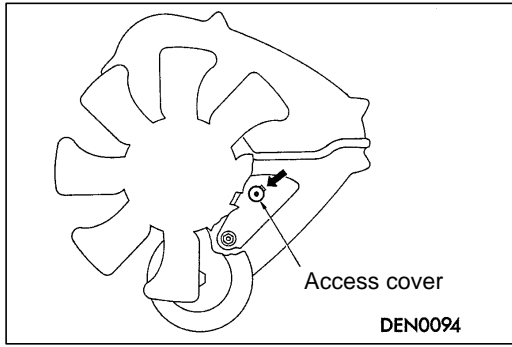

4. Remove the access cover.

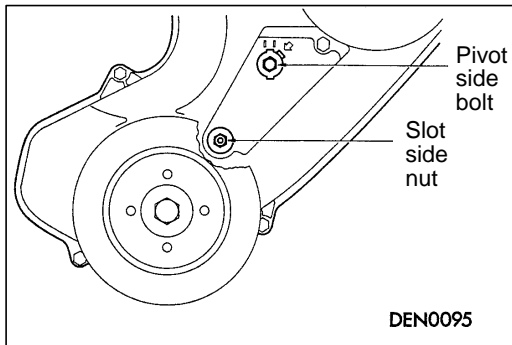

5. Loosen the tensioner pivot side bolt 1 mm and slot side nut 1 or 2 turns.
6. First tighten tensioner slot side nut, and then tighten pivot side bolt to the specified torque.

Tightening torque:

Pivot side bolt 24 Nm

Slot side nut 25 Nm

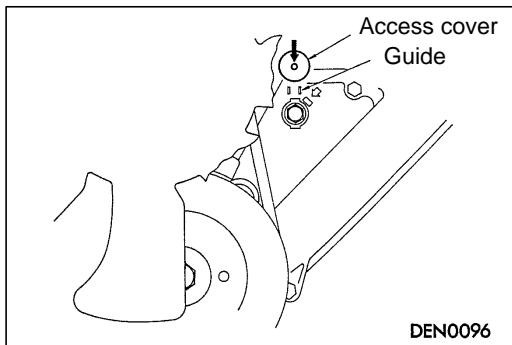

7. Install the access cover while sliding the front lower cover down along the two guides.
8. Install the timing belt upper cover.

CRANKSHAFT PULLEY**REMOVAL AND INSTALLATION****Pre-removal Operation**

- Under Cover Removal

Post-installation Operation

- Drive Belt Tension Adjustment (Refer to P.11B-5.)
- Under Cover Installation

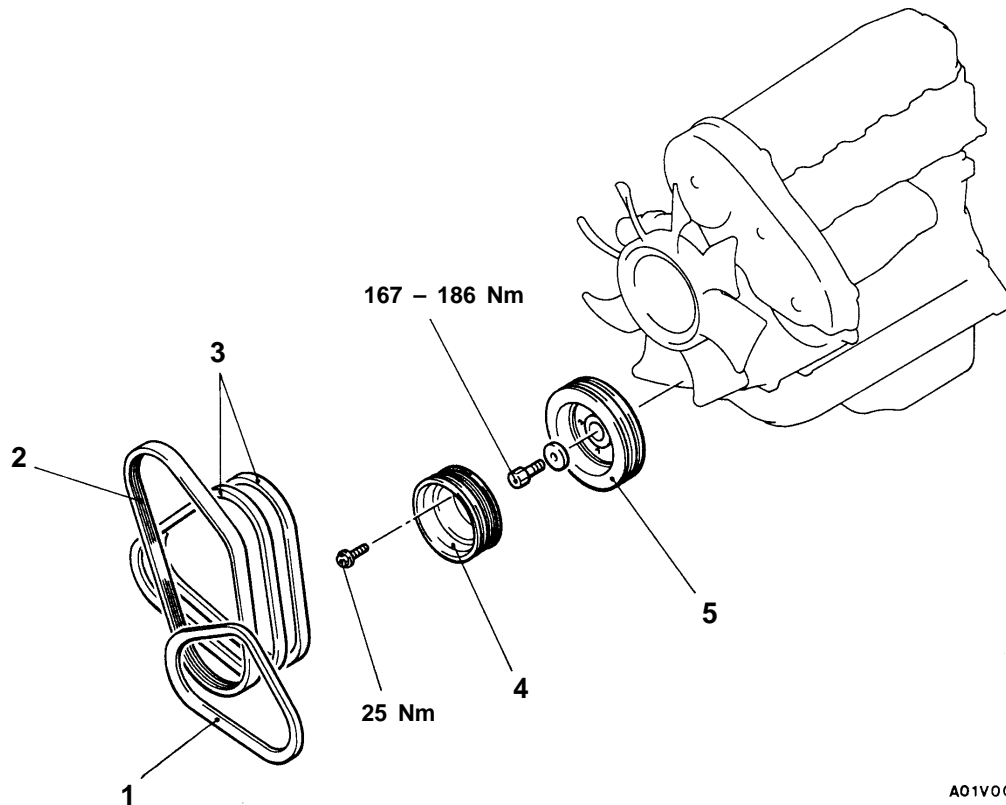

A01V0009

Removal steps

1. Drive belt (for A/C)
2. Drive belt (for power steering)
3. Drive belt (for alternator)
4. Crankshaft pulley (for power steering or A/C)
5. Crankshaft pulley

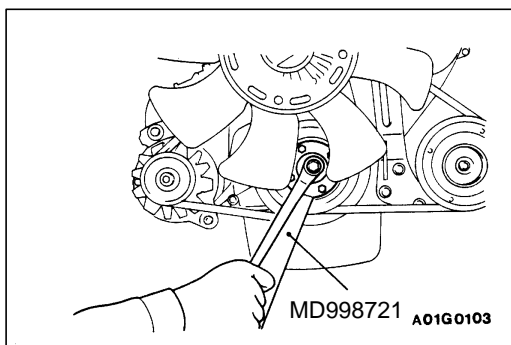

4. Crankshaft pulley (for power steering or A/C)
5. Crankshaft pulley

**REMOVAL SERVICE POINT**

◀A▶ CRANKSHAFT PULLEY REMOVAL

INSTALLATION SERVICE POINT

▶A◀ CRANKSHAFT PULLEY INSTALLATION

CAMSHAFT AND CAMSHAFT OIL SEAL

REMOVAL AND INSTALLATION

Pre-removal and Post-installation Operation

- Intercooler Removal and Installation <4WD> (Refer to GROUP 15.)

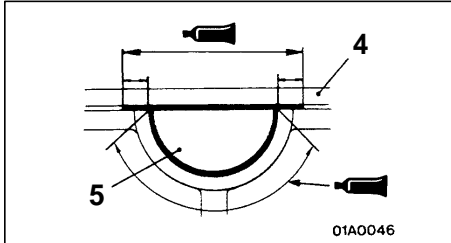

01A0046

Sealant:
3M ATD Part No. 8660 or equivalent

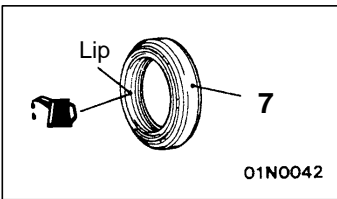

01N0042

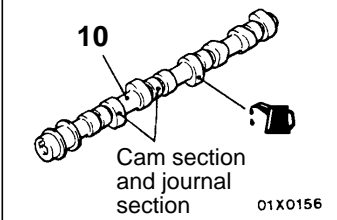

01X0156

Engine oil

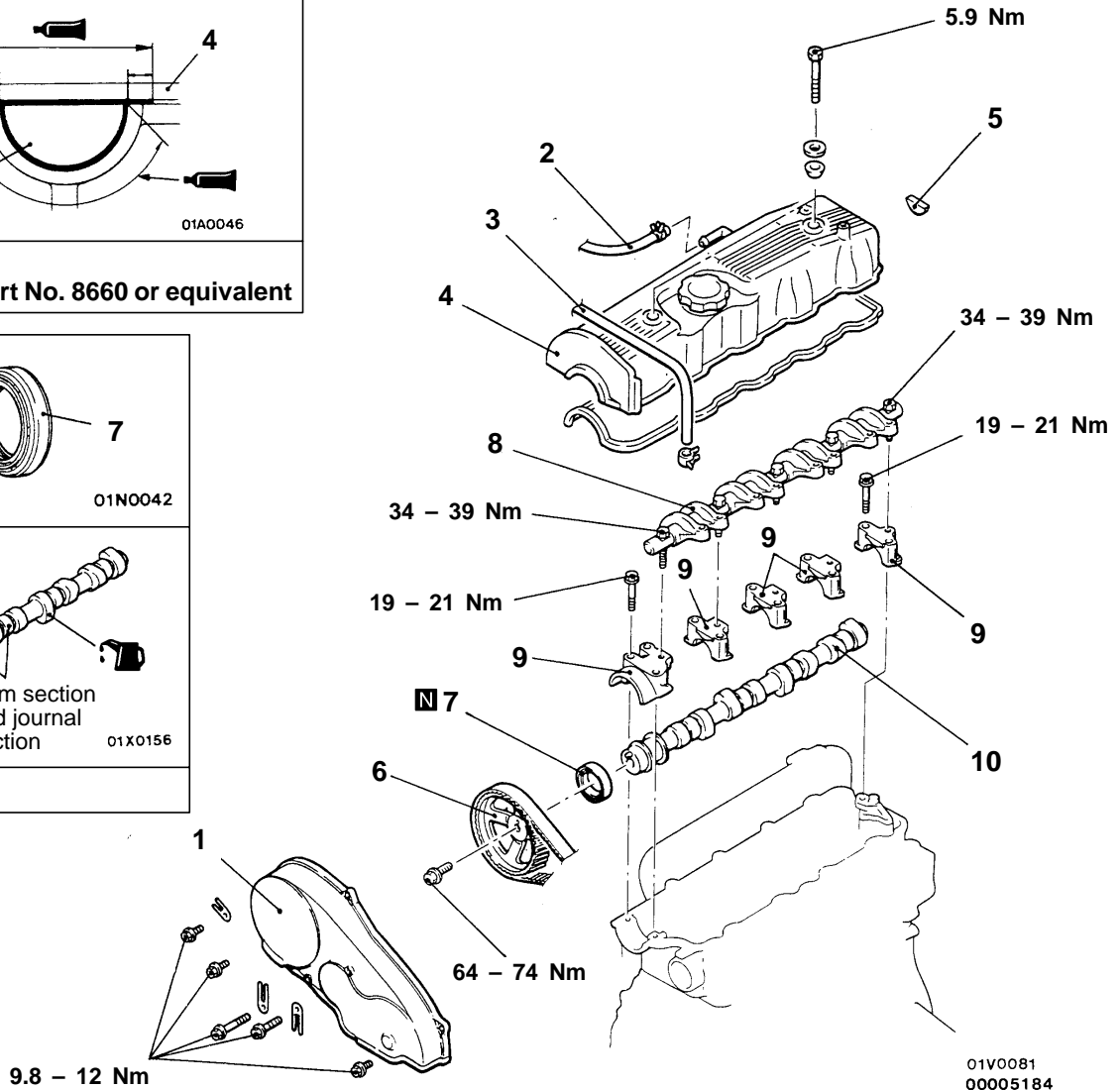

Camshaft removal steps

1. Timing belt upper cover assembly
2. Breather hose connection
3. Boost hose connection <4WD>
4. Rocker cover
5. Semi-circular packing
6. Camshaft sprocket
7. Camshaft oil seal
8. Rocker arm and shaft assembly
9. Camshaft bearing cap
10. Camshaft

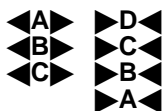

Camshaft oil seal removal steps

1. Timing belt upper cover assembly
6. Camshaft sprocket
7. Camshaft oil seal

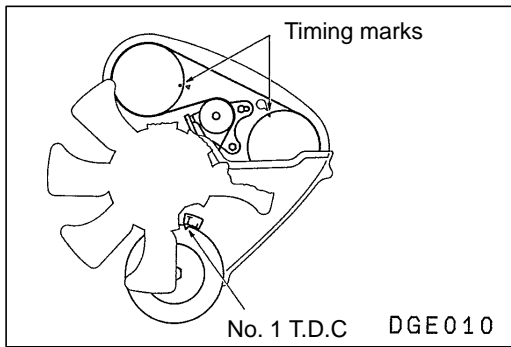

**REMOVAL SERVICE POINTS****◀A▶ CAMSHAFT SPROCKET REMOVAL**

1. Rotate crankshaft clockwise (to the right) and align timing marks.

Caution

Never turn the crankshaft anticlockwise.

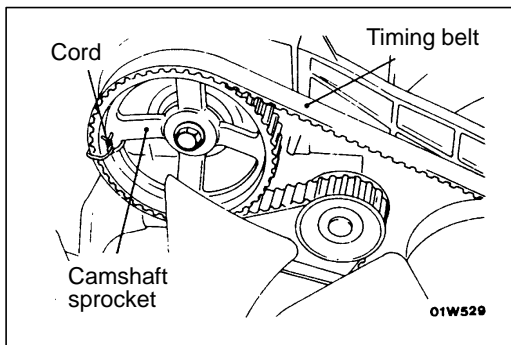

2. Tie the camshaft sprocket and timing belt together with cord so that timing mark is not maladjusted.

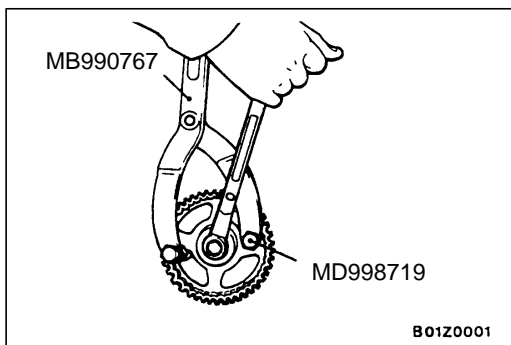

3. Use the special tool to stop the camshaft sprocket from turning, and then remove the camshaft sprocket with the timing belt still attached.

Caution

Do not rotate crankshaft after removing camshaft sprocket.

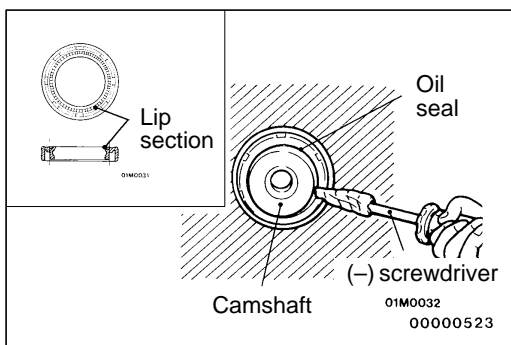
**◀B▶ CAMSHAFT OIL SEAL REMOVAL**

1. Make a notch in the oil seal lip section with a knife, etc.
2. Cover the end of a (-) screwdriver with a rag and insert into the notched section of the oil seal, and lever out the oil seal to remove it.

Caution

Be careful not to damage the camshaft and the cylinder head.

◀C▶ ROCKER ARM AND SHAFT ASSEMBLY REMOVAL

Loosen the rocker arm and shaft assembly mounting bolt, and then remove the rocker arm and shaft assembly with the bolt still attached.

Caution

Never disassemble the rocker arm and shaft assembly.

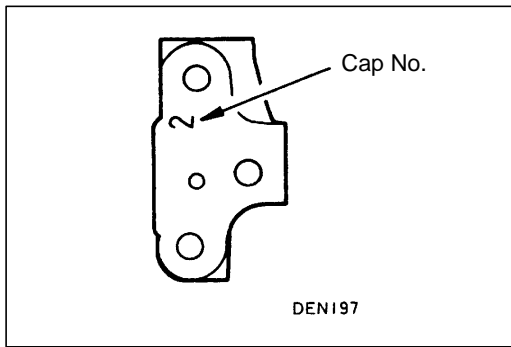

INSTALLATION SERVICE POINTS

►A◄ CAMSHAFT BEARING CAP INSTALLATION

The cap numbers are embossed on the top surface of the bearing caps, so install in the order of the numbers. However, no numbers are embossed on bearing caps 1 and 5.

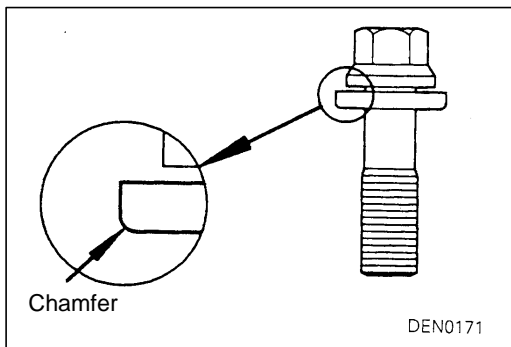

►B◄ ROCKER ARM AND SHAFT ASSEMBLY INSTALLATION

1. Install the rocker arm and shaft assembly to the bearing caps.
2. Set the washer so that it faces in the direction shown in the illustration, and then install the bolt.
3. Check the valve clearance and adjust if necessary. (Refer to P.11B-8.)

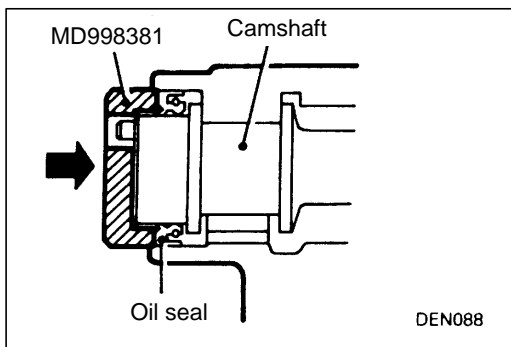

►C◄ CAMSHAFT OIL SEAL INSTALLATION

1. Apply a small amount of engine oil to the entire circumference of the oil seal lip and camshaft.
2. Use the special tool to tap in the oil seal.

NOTE

The oil seal should be tapped in until the distance from the end of the camshaft to the end of the oil seal is as shown in the illustration.

►D◄ CAMSHAFT SPROCKET INSTALLATION

1. Use the special tool in the same way as during removal to stop the camshaft sprocket from turning, and then tighten the bolt to the specified torque.

Tightening torque: 64 – 67 Nm

2. Remove the cord which binds the camshaft sprocket and timing belt.

OIL PAN AND OIL SCREEN

REMOVAL AND INSTALLATION

Pre-removal and Post-installation Operation

- Under Cover Removal and Installation
- Engine Oil Draining and Supplying
(Refer to GROUP 12 – On-vehicle Service.)

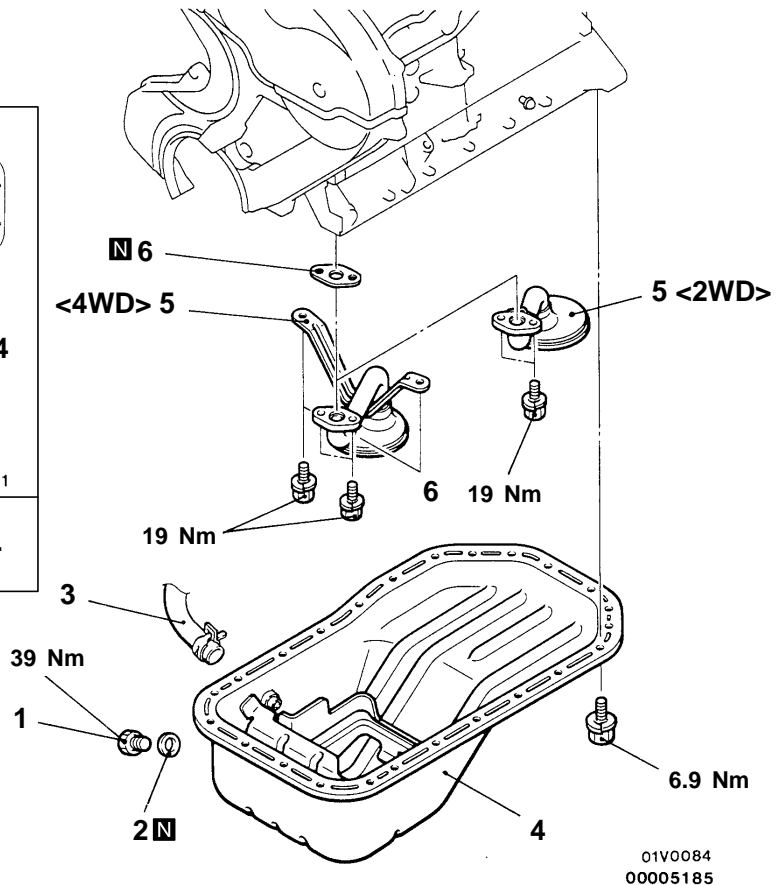
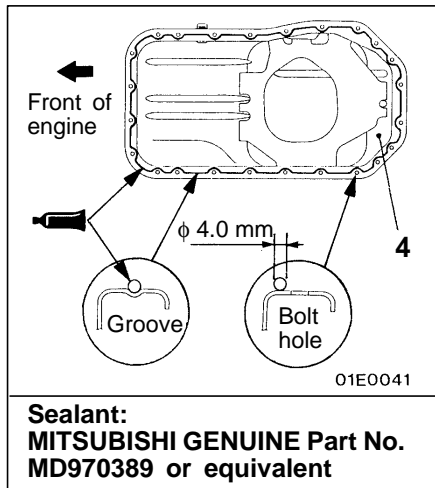

Removal steps

- ▶B◀
1. Drain plug
 2. Drain plug gasket
 3. Oil return hose connection

- ◀A▶ ▶A◀
4. Oil pan
 5. Oil screen
 6. Gasket

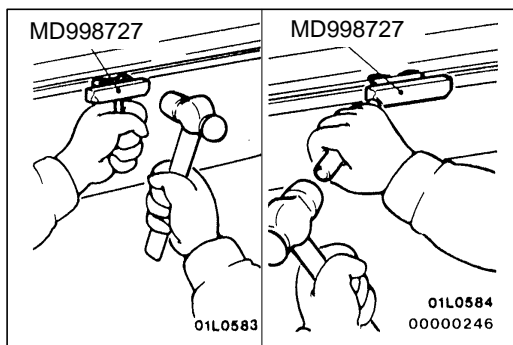

REMOVAL SERVICE POINT

◀A▶ **OIL PAN REMOVAL**

1. Remove oil pan bolts.
2. Tap the special tool in between the oil pan and cylinder block.
3. Slide the special tool by tapping it at an angle to remove the oil pan.

Caution

The use of a screwdriver or chisel in place of the special tool can damage the gasket seat surface and cause oil leakage.

INSTALLATION SERVICE POINTS**▶A◀ OIL PAN INSTALLATION**

1. Remove sealant from oil pan and cylinder block mating surfaces.
2. Degrease the sealant-coated surface and the engine mating surface.
3. Apply the specified sealant around the gasket surface of oil pan.

Specified sealant:

MITSUBISHI GENUINE PART No. MD970389 or equivalent

NOTE

The sealant should be applied in a continuous bead approximately 4 mm in diameter.

4. Assemble oil pan to cylinder block within 15 minutes after applying the sealant.

Caution

After installing the oil pan, wait at least 1 hour before starting the engine.

▶B◀ DRAIN PLUG GASKET INSTALLATION

Install a new gasket in the direction so that it faces as shown in the illustration.

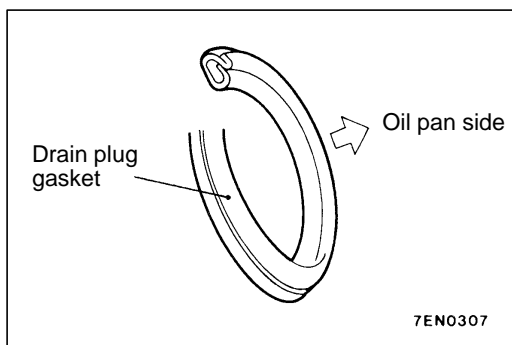
**INSPECTION**

11200260041

- Check oil pan for cracks.
- Check oil pan sealant-coated surface for damage and deformation.
- Check oil screen for cracked, clogged or damaged wire net and pipe.

CYLINDER HEAD GASKET

REMOVAL AND INSTALLATION

Pre-removal Operation

- Intake and Exhaust Manifold Removal (Refer to GROUP 15.)
- Timing Belt Removal (Refer to P.11B-26.)
- Engine Coolant Draining (Refer to GROUP 14 – On-vehicle Service.)

Post-installation Operation

- Timing Belt Installation (Refer to P.11B-26.)
- Intake and Exhaust Manifold Installation (Refer to GROUP 15.)
- Fuel Line Air Bleeding (Refer to GROUP 13E – On-vehicle Service.)
- Engine Coolant Filling (Refer to GROUP 14 – On-vehicle Service.)

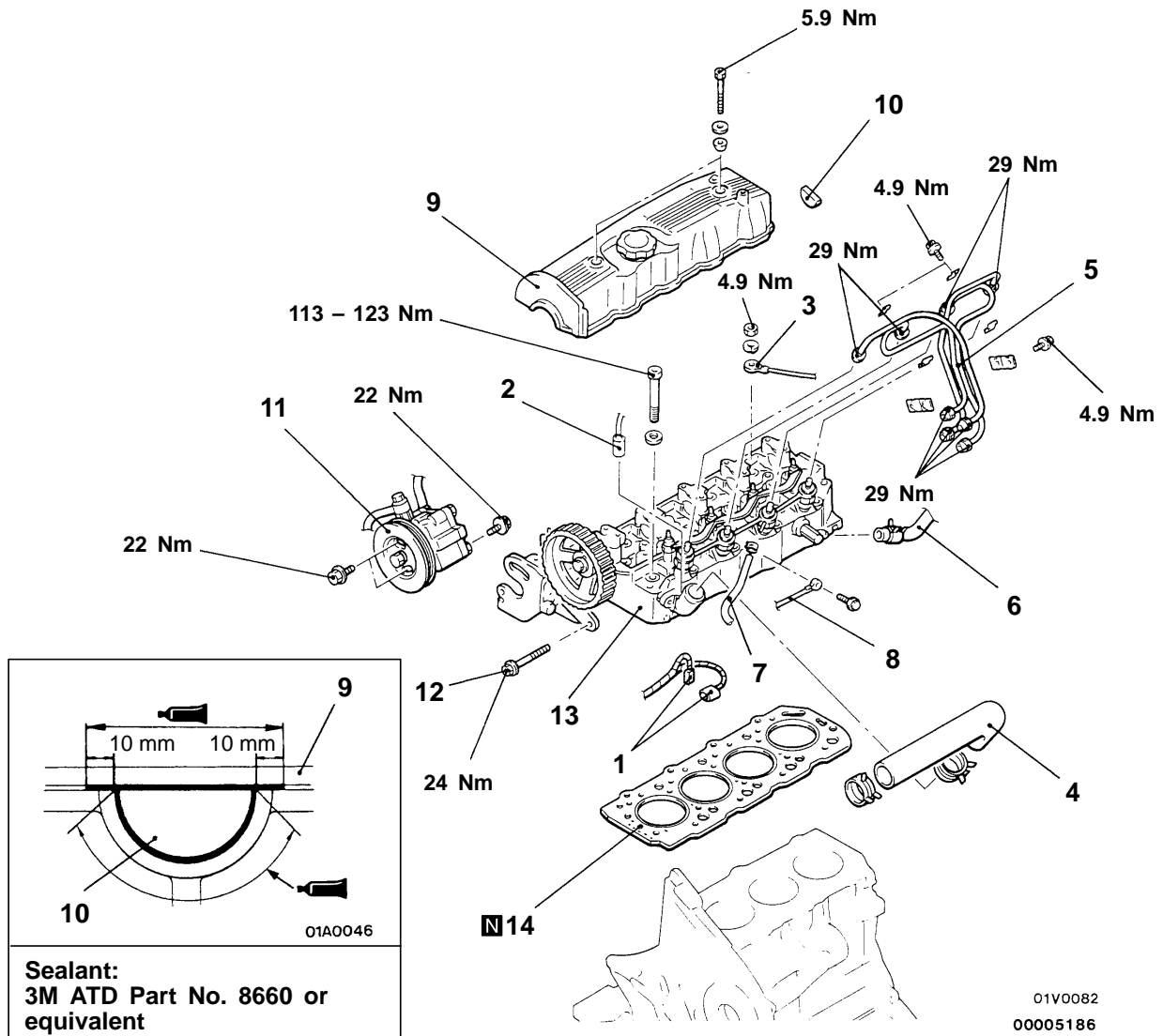

Sealant:
3M ATD Part No. 8660 or
equivalent

Removal steps

1. Engine coolant temperature switch connector (for A/C)
2. Engine coolant temperature gauge unit and sensor connector
3. Glow plug terminal
4. Radiator upper hose
5. Fuel injection pipe
6. Heater hose or water by-pass hose connection

7. Fuel hose connection
8. Earth cable connection
9. Rocker cover
10. Semi-circular packing
11. Power steering oil pump assembly
12. Power steering oil pump bracket bolt
13. Cylinder head assembly
14. Cylinder head gasket



REMOVAL SERVICE POINTS**◀A▶ RADIATOR UPPER HOSE DISCONNECTION**

After making mating marks on the radiator upper hose and the hose clamp, disconnect the radiator upper hose.

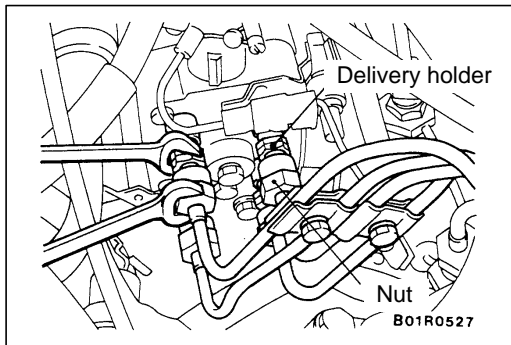
**◀B▶ FUEL INJECTION PIPE REMOVAL**

When loosening nuts at both ends of injection pipe, hold the delivery holder (for pump side) and the injection nozzle assembly (for nozzle side) with wrench and loosen nut.

Caution

After disconnecting the injection pipe, plug the opening so that no foreign particles get inside the pump or into the injection nozzle.

◀C▶ POWER STEERING OIL PUMP REMOVAL

Remove the power steering oil pump from the bracket with the hose attached.

NOTE

Place the removed power steering oil pump in a place where it will not be a hindrance when removing and installing the engine assembly, and tie it with a cord.

◀D▶ CYLINDER HEAD ASSEMBLY REMOVAL

Use the special tool to tighten each bolt 2 – 3 times in the order shown in the illustration.

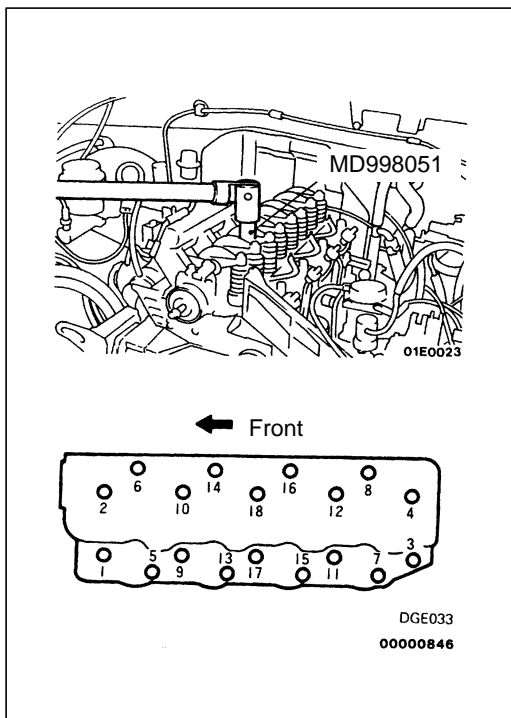

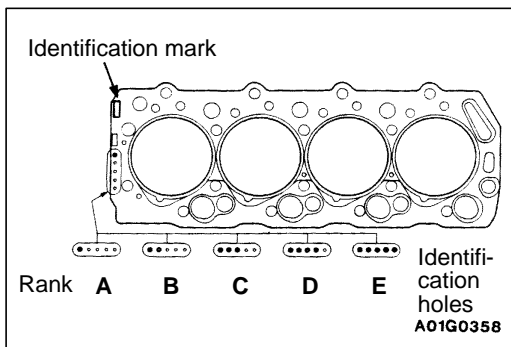

INSTALLATION SERVICE POINTS

►A◄ CYLINDER HEAD GASKET INSTALLATION

1. Wipe off any oil or grease from the gasket mounting surface.
2. Check the rank from the number of identification holes on the cylinder head gasket that was removed, and select a cylinder head gasket of the same rank.

NOTE

The ranks are listed in the parts catalogue.

3. Place the cylinder head gasket on top of the cylinder block so that the identification mark is facing upwards as in the illustration.

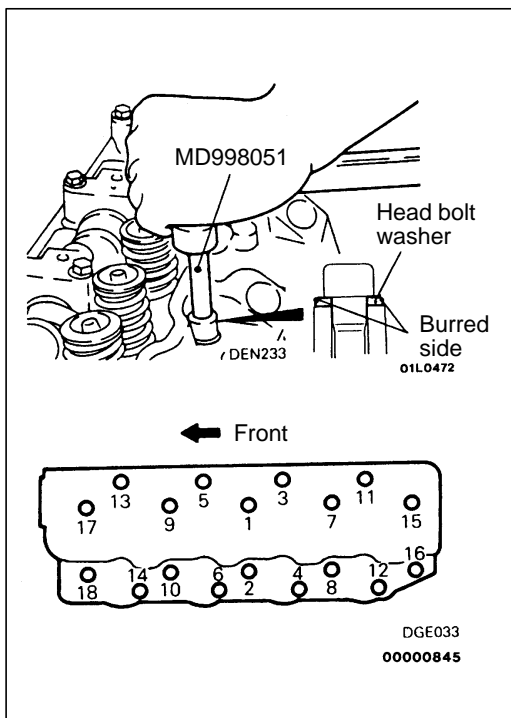

►B◄ CYLINDER HEAD INSTALLATION

Use the special tool to tighten each bolt 2 – 3 times in the order shown in the illustration.

Caution

The head bolt washer should be installed so that the burred side is facing upwards.

►C◄ RADIATOR UPPER HOSE CONNECTION

To reuse the radiator upper hose, align the mating marks that were made during removal, and then install the hose clamp.

►D◄ FUEL INJECTION PIPE INSTALLATION

When tightening the nuts at both ends of the fuel injection pipe, hold the delivery holder (for pump side) and the injection nozzle assembly (for nozzle side) with a wrench, and tighten the nuts to the specified torque.

TIMING BELT AND TIMING BELT B

REMOVAL AND INSTALLATION

Pre-removal Operation

- Cooling Fan Removal (Refer to GROUP 14.)

Post-installation Operation

- Cooling Fan Installation (Refer to GROUP 14.)
- Engine Adjustment (Refer to P.11B-5.)

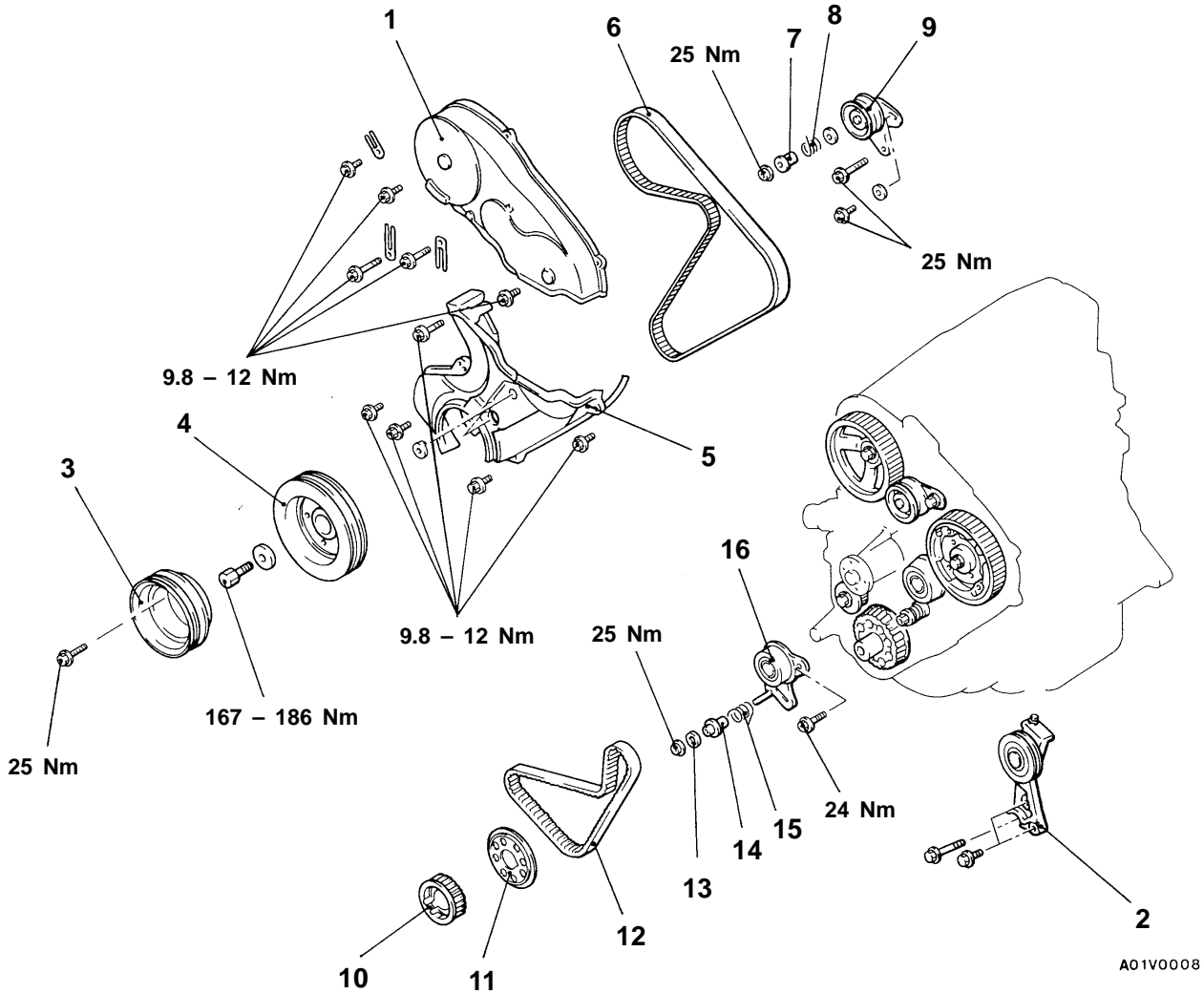

Removal steps

1. Timing belt front upper cover
2. Tension pulley bracket (for A/C)
3. Crankshaft pulley (for power steering and A/C)
4. Crankshaft pulley
5. Timing belt front lower cover
6. Timing belt
7. Tensioner spacer
8. Tensioner spring

9. Timing belt tensioner assembly
10. Crankshaft sprocket
11. Flange
12. Timing belt B
13. Gasket
14. Tensioner spacer B
15. Tensioner spring B
16. Timing belt tensioner B

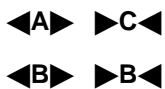

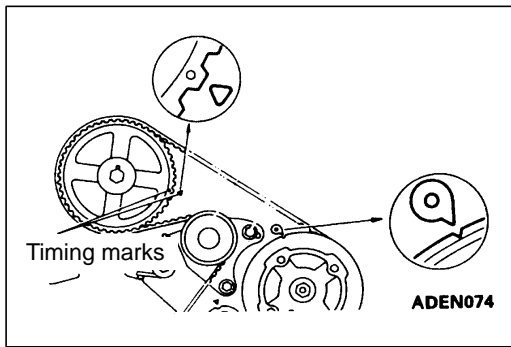
**REMOVAL SERVICE POINTS****◀A▶ CRANKSHAFT PULLEY REMOVAL**

1. Position the No. 1 cylinder at compression TDC and remove the crankshaft pulley.

NOTE

The No. 1 cylinder is at compression TDC when the marks are aligned as shown in the figure.

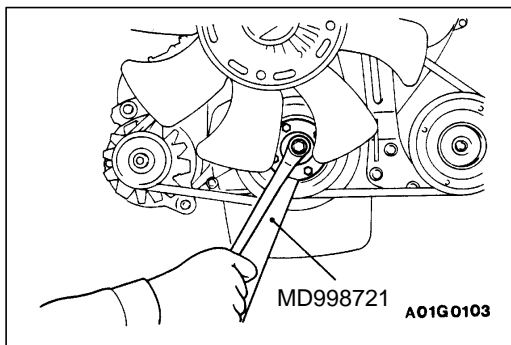

2. Use the special tool to keep crankshaft from turning and remove the bolts.

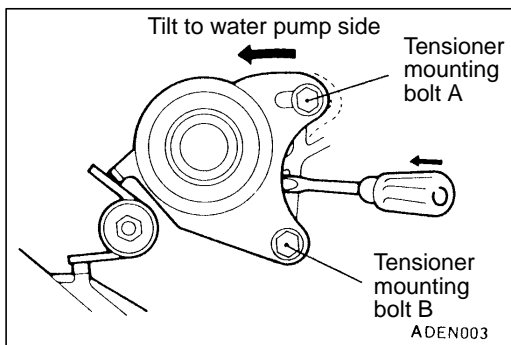
**◀B▶ TIMING BELT REMOVAL**

1. When reinstalling timing belt, mark an arrow at the belt to show rotation direction.
2. Loosen the tensioner mounting bolt A and B.
3. Push timing belt tensioner to water pump side and tighten the tensioner mounting bolt A and B. Secure so that tensioner will not move back.

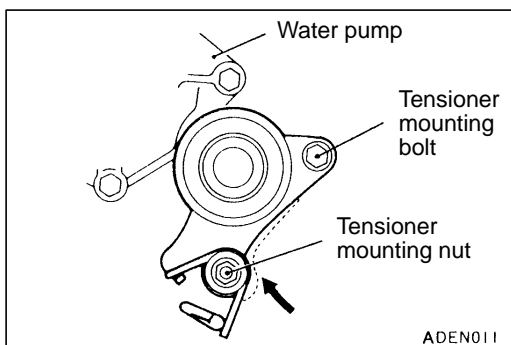
**◀C▶ TIMING BELT B REMOVAL**

1. When reinstalling timing belt "B", mark an arrow at the belt to show rotation direction.
2. Loosen the tensioner mounting bolt and nut.
3. Push timing belt tensioner to water pump side and tighten the tensioner mounting bolt and nut. Secure so that tensioner will not move back.

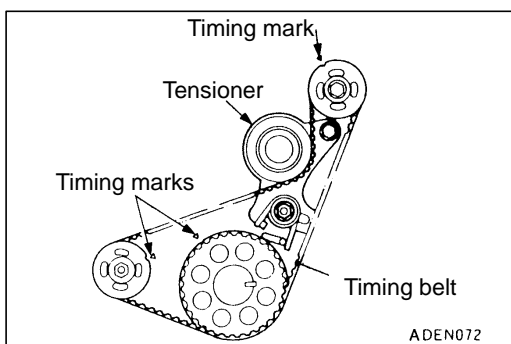
**INSTALLATION SERVICE POINTS****▶A◀ TIMING BELT B INSTALLATION**

1. Align the timing marks of the 3 sprockets.
2. When reusing timing belt "B", make sure the arrow mark is pointing in the same direction as when the belt was removed.

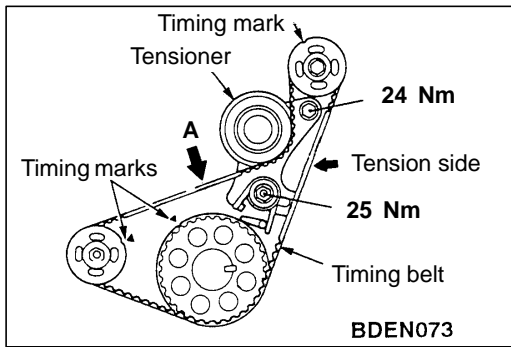

3. Install timing belt B and make sure there is no deflection on the tension side.
4. Press the deflection side of timing belt B (indicated by arrow (A)) with the hand and fully stretch the tensioner side.
5. Make sure that the timing marks are aligned.
6. Loosen the tensioner mounting bolt and nut so that only the pressure of the spring is applied to timing belt B.
7. Tighten the tensioner mounting bolt and nut, tightening the nut first. If the bolt is tightened first, the tensioner will move and tension the belt.

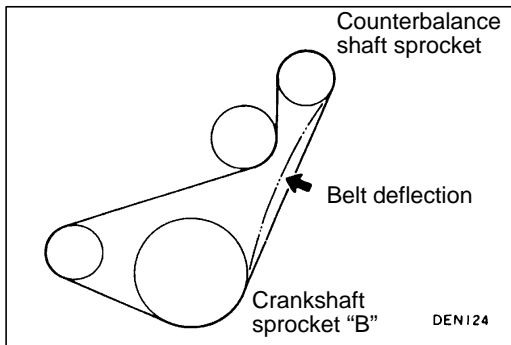

8. Press in the direction of the arrow in the figure with the index finger to check the amount of deflection.

Standard value: 4 – 5 mm

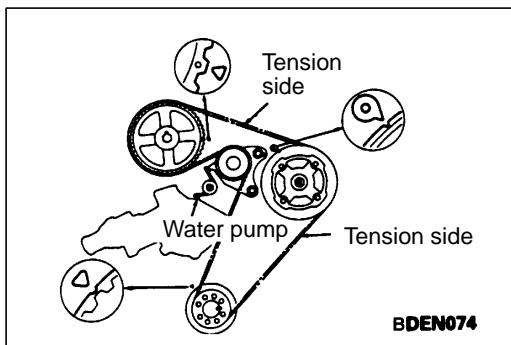

►B◄ TIMING BELT INSTALLATION

1. Align the timing marks of the 3 sprockets.
2. When reusing timing belt, make sure the arrow mark is pointing in the same direction as when the belt was removed.
3. Install the timing belt to the crankshaft sprocket, to injection pump sprocket, to tensioner and to camshaft sprocket in that order. Being careful not to allow deflection on the tension side of the timing belt.

Caution

1. Engage the belt on the various sprockets while maintaining tension on the belt of tension side.
2. Align the injection pump sprocket with the timing mark, hold the sprocket so that it does not turn and engage the belt.

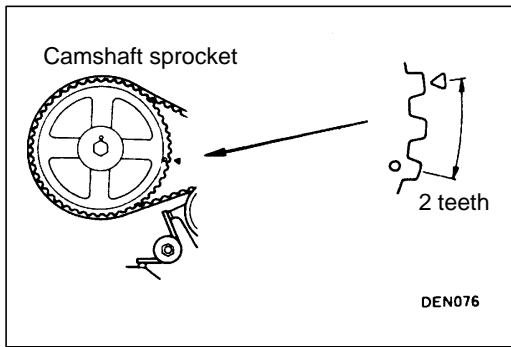

4. Loosen the tensioner mounting bolts and apply tension with the spring.
5. Turn the crankshaft clockwise and stop at the second lobe of the camshaft sprocket.

Caution

1. When turning the crankshaft in item (5), strictly observe the specified amount of rotation (2 teeth on the camshaft sprocket) in order to apply a constant force to the tension side of the belt.
2. Do not turn the crankshaft counterclockwise.
3. Do not touch the belt during adjustment.

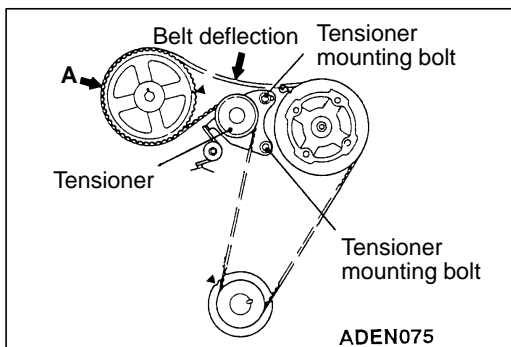

6. Make sure that the part indicated by arrow A does not float upward.
7. Tighten the tensioner mounting bolts, starting with the bolt in the elongated hole. If the lower bolt is tightened first, belt tension will become too tight.

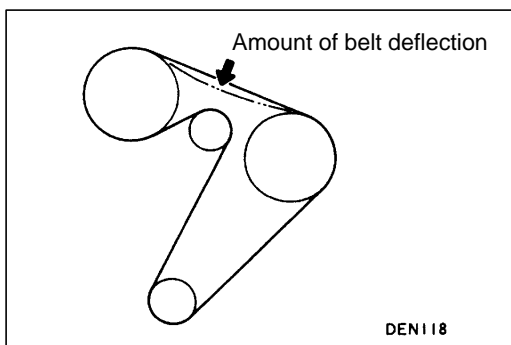

8. Turn the crankshaft anticlockwise and align the timing mark. Next, make sure that the timing marks of all sprockets are aligned.
9. Press on the centre of the bolt with an index finger to check the amount of deflection.

Standard value: 4 – 5 mm

►C◄ CRANKSHAFT PULLEY INSTALLATION

Using the special tool to install the crankshaft pulley as same as removal procedure.

CRANKSHAFT FRONT OIL SEAL

REMOVAL AND INSTALLATION

Pre-removal and Post-installation Operation

- Timing Belt and Timing Belt “B” Removal and Installation (Refer to P.11B-26.)

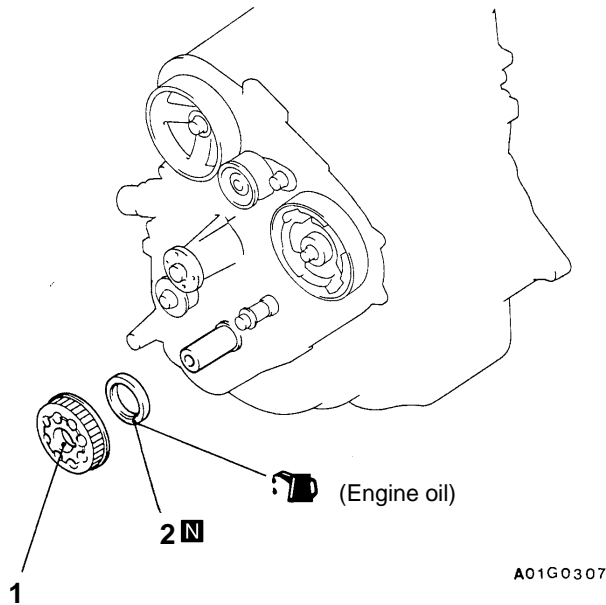

Removal steps

- ◀A▶ ▶A◀
1. Crankshaft sprocket B
 2. Oil seal

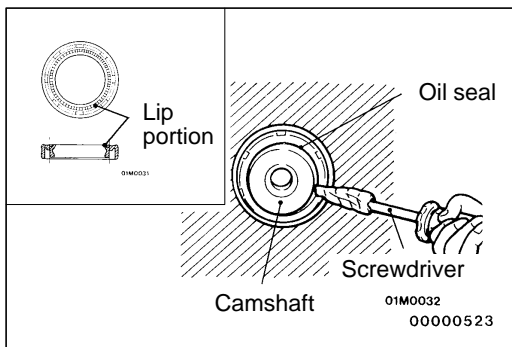

REMOVAL SERVICE POINT

◀A▶ **OIL SEAL REMOVAL**

1. Cut out a portion in the crankshaft oil seal lip.
2. Cover the tip of a screwdriver with a cloth and apply it to the cutout in the oil seal to pry off the oil seal.

Caution

Be careful not to damage the crankshaft and front case.

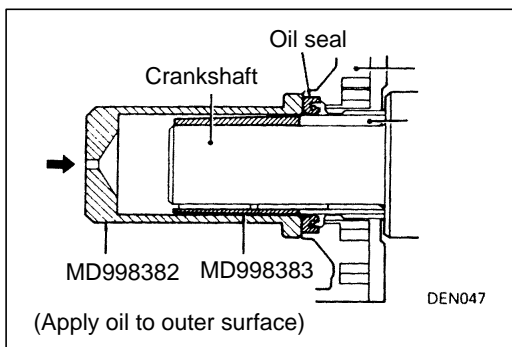

INSTALLATION SERVICE POINT

▶A◀ **OIL SEAL INSTALLATION**

Apply engine oil to the outside of the special tool (MD998383) and to the oil seal lip, and use the special tool to press-fit the oil seal.

CRANKSHAFT REAR OIL SEAL

REMOVAL AND INSTALLATION

Pre-removal and Post-installation Operation

- Oil Pan Removal and Installation (Refer to P.11-21.)
- Transmission Assembly Removal and Installation (Refer to GROUP 22, 23.)

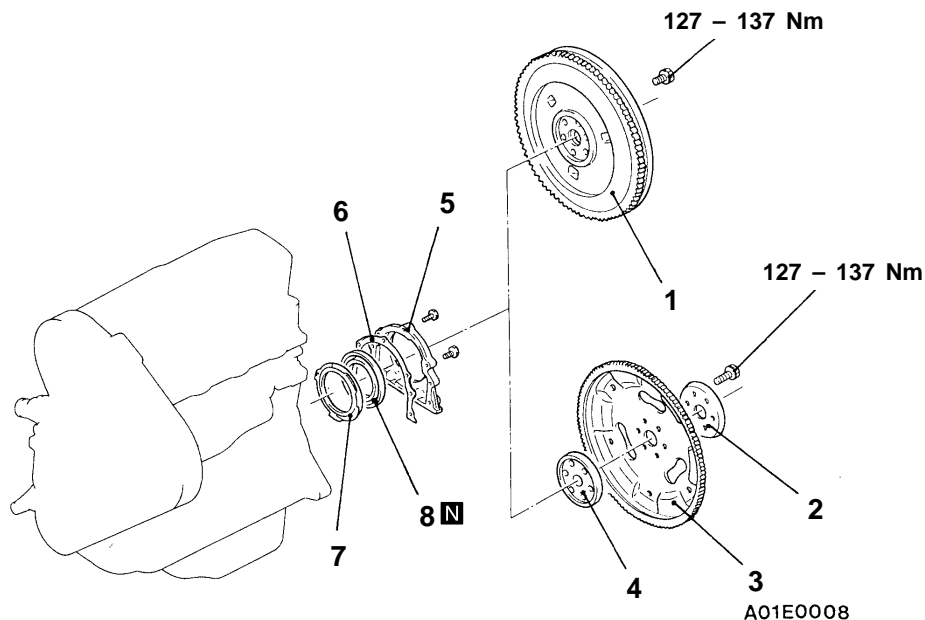

Removal steps



1. Flywheel assembly <M/T>
2. Adaptor plate <A/T>
3. Drive plate <A/T>
4. Crankshaft adaptor <A/T>



5. Oil seal case
6. Gasket
7. Oil separator
8. Oil seal

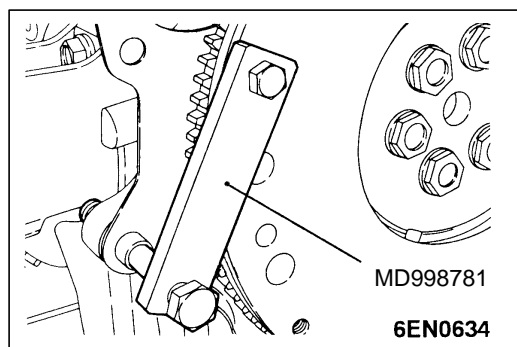

REMOVAL SERVICE POINT

<A> FLYWHEEL <M/T>/ADAPTOR PLATE <A/T> REMOVAL

Use the special tool to secure the flywheel or adaptor plate and remove the bolt.

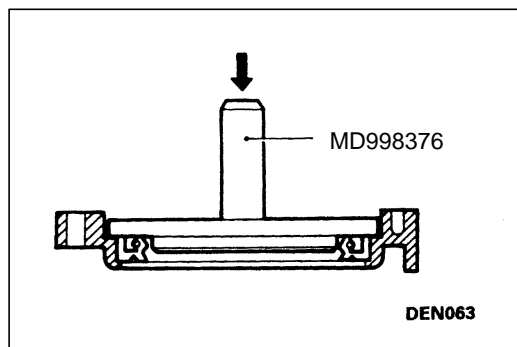

INSTALLATION SERVICE POINTS

>A< OIL SEAL INSTALLATION

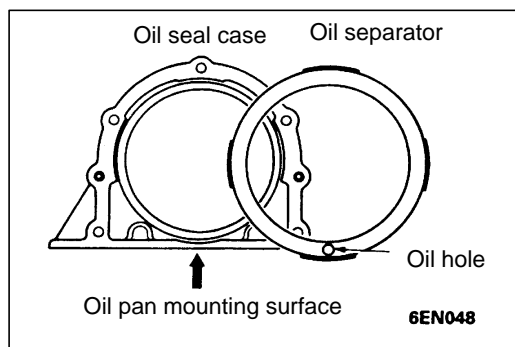
**►B◄ OIL SEPARATOR INSTALLATION**

Install the oil separator in such a way that its oil hole come at the case bottom (indicated by an arrow in the illustration).

►C◄ FLYWHEEL <M/T>/ADAPTOR PLATE <A/T> INSTALLATION

Use the special tool in the same way as during removal to stop the flywheel or adaptor plate assembly from turning, and then tighten the bolt to the specified torque.

Tightening torque: 127 – 137 Nm

ENGINE ASSEMBLY**REMOVAL AND INSTALLATION****Pre-removal Operation**

- Hood Removal (Refer to GROUP 42.)
- Intercooler Removal <4WD> (Refer to GROUP 15.)
- Air Cleaner and Air Intake Hose Removal (Refer to GROUP 15.)
- Brake Master Cylinder Heat Protector Removal <4WD>
- Battery Removal
- Radiator Removal (Refer to GROUP 14.)
- Transmission Assembly Removal <2WD> (Refer to GROUP 22.)
- Transmission and Transfer Assembly Removal <4WD> (Refer to GROUP 22, 23.)

Post-installation Operation

- Transmission and Transfer Assembly Installation <4WD> (Refer to GROUP 22, 23.)
- Transmission Assembly Installation <2WD> (Refer to GROUP 22.)
- Radiator Installation (Refer to GROUP 14.)
- Battery installation
- Brake Master Cylinder Heat Protector Installation <4WD>
- Air Cleaner and Air Intake Hose Installation (Refer to GROUP 15.)
- Intercooler Installation <4WD> (Refer to GROUP 15.)
- Hood Installation (Refer to GROUP 42.)
- Drive Belt Tension Adjustment (Refer to P.11B-5.)
- Accelerator Cable Adjustment (Refer to GROUP 17 – On-vehicle Service.)
- Throttle Cable Adjustment <A/T> (Refer to GROUP 23 – On-vehicle Service.)

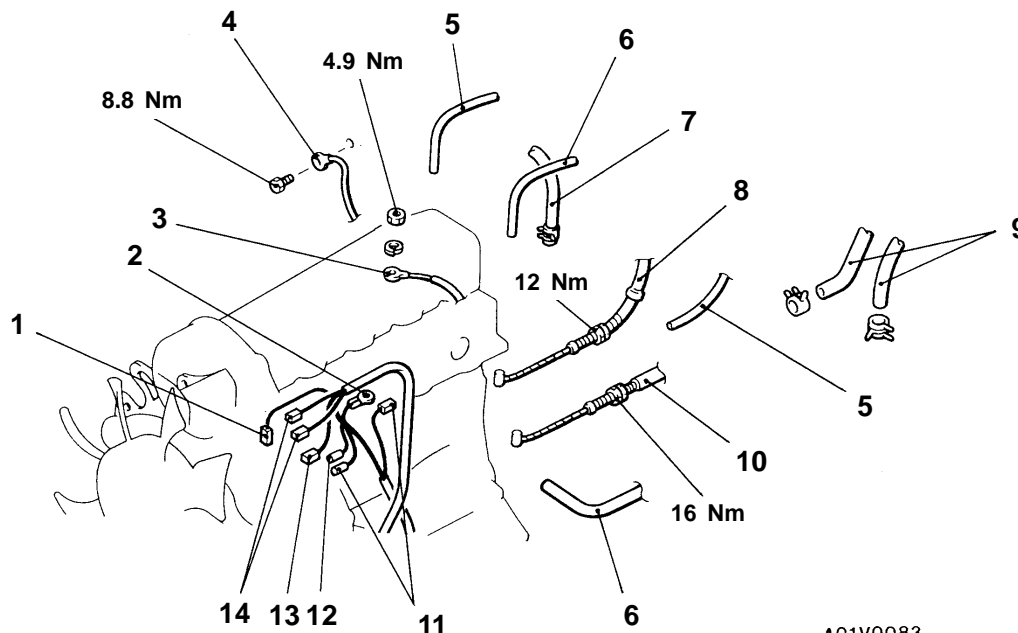

A01V0083

Removal steps

1. Engine coolant temperature sensor and gauge unit connector
2. Earth cable connector
3. Glow plug terminal
4. Earth cable connector
5. Vacuum hose connection (for A/C)
6. Vacuum hose connection (for ABS)
7. Brake booster vacuum hose connection
8. Accelerator cable connection
9. Heater hose connections
10. Throttle cable connection <A/T>
11. Fuel cut solenoid valve or fuel cut valve controller connector
12. Revolution pick-up sensor connector
13. Lever (throttle) position switch connector
14. Engine coolant temperature switch connector (for A/C)

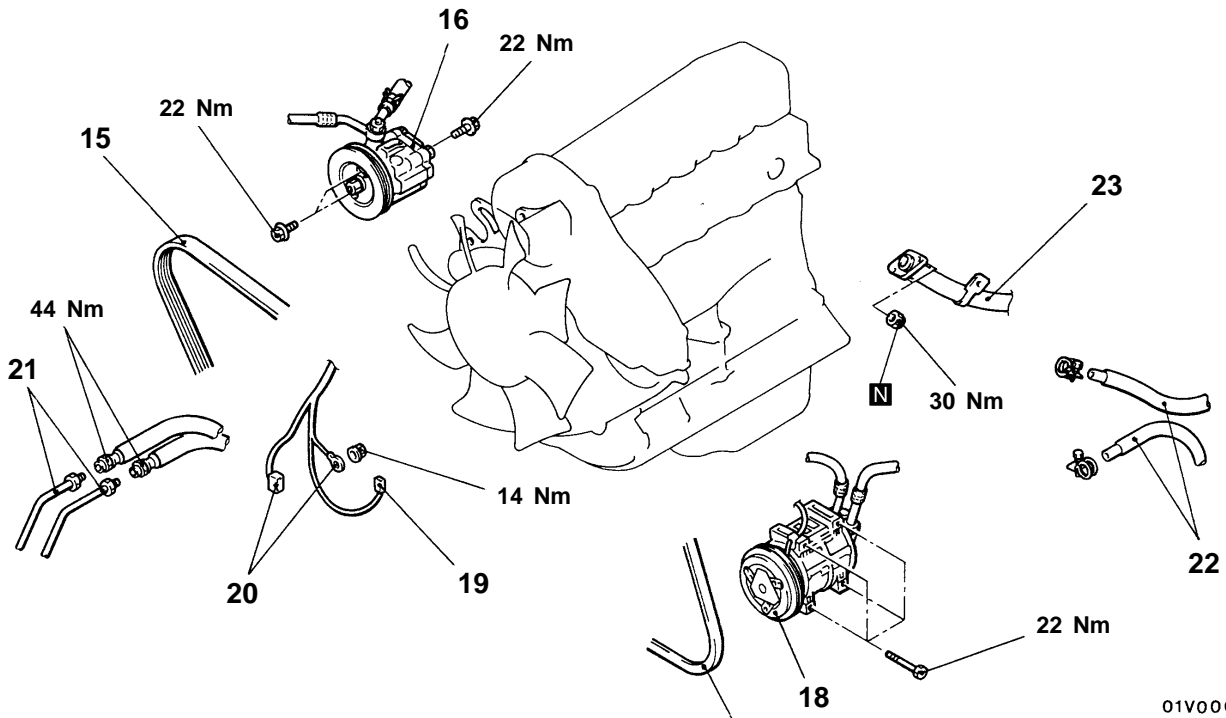

01V0006

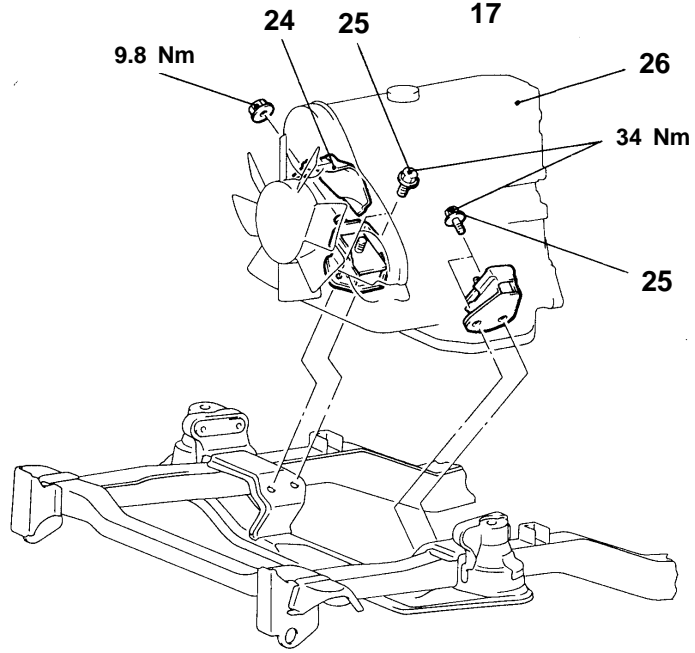

01V0012
00005187

- ◀A▶ 15. Drive belt (for Power steering)
- ◀A▶ 16. Power steering oil pump assembly
- ◀A▶ 17. Drive belt (for A/C)
- ◀A▶ 18. A/C compressor assembly
- ◀A▶ 19. Engine oil pressure switch connector
- ◀A▶ 20. Alternator connector
- ◀B▶ ▶A▶ 21. Engine oil cooler hose connection
- ◀B▶ ▶A▶ 22. Fuel hose connections
- ◀B▶ ▶A▶ 23. Front exhaust pipe connection
- ◀B▶ ▶A▶ 24. Heat protector
- ◀B▶ ▶A▶ 25. Engine support front insulator attaching bolt
- ◀B▶ ▶A▶ 26. Engine assembly

REMOVAL SERVICE POINTS**◀A▶ POWER STEERING OIL PUMP ASSEMBLY AND A/C COMPRESSOR ASSEMBLY REMOVAL**

1. Remove the oil pump and A/C compressor (with the hose attached).
2. Suspend the removed oil pump (by using wire or similar material) at a place where no damage will be caused during removal/installation of the engine assembly.

◀B▶ ENGINE ASSEMBLY REMOVAL

1. Check that all cables, hoses, harness connectors, etc. are disconnected from the engine.
2. Lift the chain block slowly to remove the engine assembly upward from the engine compartment.

INSTALLATION SERVICE POINT**▶A◀ ENGINE ASSEMBLY INSTALLATION**

Install the engine assembly. When doing so, check carefully that all pipes and hoses are connected, and that none are twisted, damaged, etc.

NOTES

ENGINE <4D5>

CONTENTS

GENERAL	2	Injection Timing Check and Adjustment	3
Outline of Changes	2	Idle Speed Check	3
GENERAL INFORMATION	2	OIL PAN <4D56-Step III>	4
SERVICE SPECIFICATIONS	2	CYLINDER HEAD GASKET	
SPECIAL TOOLS	2	<4D56-Step III>	5
ON-VEHICLE SERVICE	3	TIMING BELT AND TIMING BELT B	
		<4D56-Step III>	7

GENERAL

OUTLINE OF CHANGES

- The following service procedures have been established due to the introduction of the electronic-controlled injection pump. Other service procedures are the same as before. <4D56-Step III>
- Oil pan cover has been adopted. <4D56-Step III>
- The tightening torque of the cylinder head bolts and the cylinder head gasket have been changed.<4D56-Step III>

GENERAL INFORMATION

Items	4D56	
Total displacement mL	2,477	
Bore x Stroke mm	91.1 x 95.0	
Compression ratio	21	
Combustion chamber	Vortex chamber type	
Camshaft arrangement	SOHC	
Number of valve	Intake	4
	Exhaust	4
Valve timing	Intake	Opening BTDC 20°, Closing ABDC 49°
	Exhaust	Opening BBDC 55°, Closing ATDC 22°
Fuel system	Electronic-controlled injection pump	
Rocker arm	Roller type	
Adjusting screw	Elephant foot type	

SERVICE SPECIFICATIONS

Items	Standard value	Limit
Idle speed r/min	750 ± 30	–

SPECIAL TOOLS

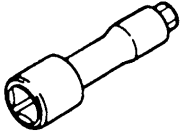
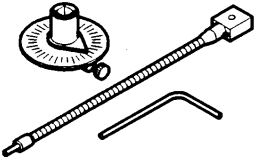
Tools	Number	Name	Use
	MD998051	Cylinder head bolt wrench	Removal and installation of the cylinder head bolt
	MB991614	Angle gauge	Tightening of the cylinder head bolts

ON-VEHICLE SERVICE

INJECTION TIMING CHECK AND ADJUSTMENT

Inspection and adjustment are the same as before. The electronic-controlled injection pump does not have a cold start device (wax-type).

IDLE SPEED CHECK

1. Set the vehicle to the pre-inspection condition.
2. Turn the ignition switch to “LOCK” (OFF) position, and connect the diagnosis connector to the MUT-II. If the MUT-II is not used, connect a tachometer to the injection nozzle or the pipe.
3. Start the engine, and let it run at idle.
4. Check the idle speed.

Standard value: 750 ± 30 r/min

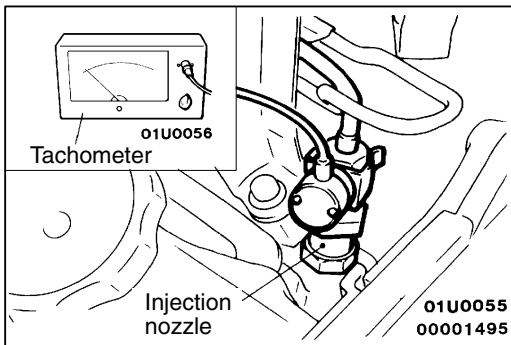
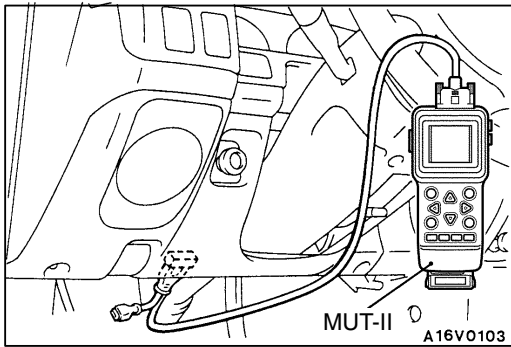

5. If the idle speed is not within the standard value, refer to 13I – Troubleshooting to check the electronic-controlled fuel injection system.

NOTE

The idle speed is controlled by the engine-ECU.

OIL PAN <4D56-Step III>

REMOVAL AND INSTALLATION

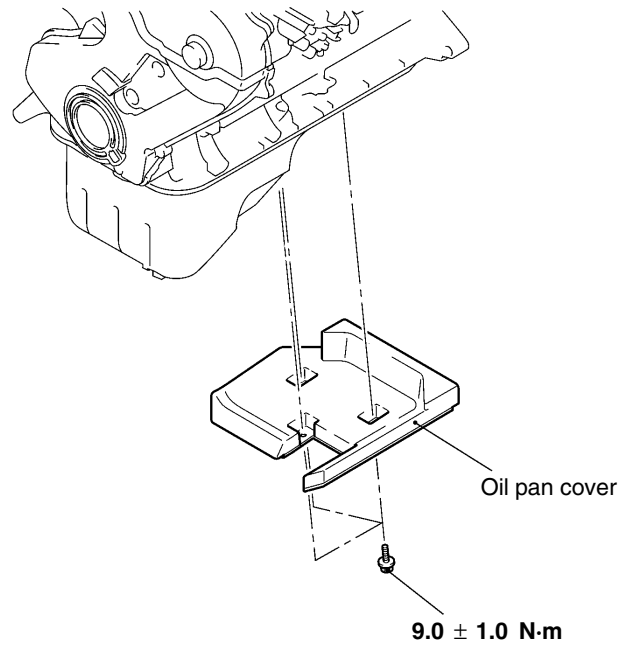

A10048AA

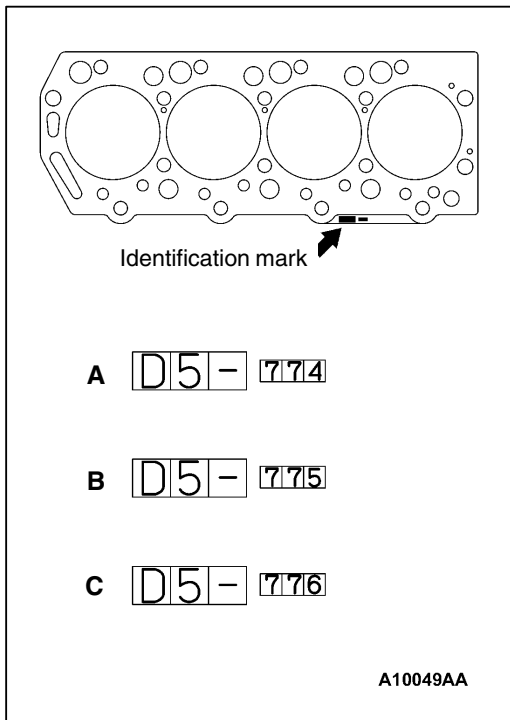

CYLINDER HEAD GASKET <4D56-Step III>

INSTALLATION SERVICE POINT

CYLINDER HEAD GASKET AND CYLINDER HEAD INSTALLATION

1. Wipe off any oil or grease from the gasket mounting surface.
2. If you replace the cylinder head gasket only, check the identification mark of the cylinder head gasket removed, select the cylinder head gasket that has same identification mark (size) from the table below.

Spec	Identification mark (size)	Parts number
A	D5-774 (Thickness on tightening: 1.45 ± 0.04)	MD377774
B	D5-775 (Thickness on tightening: 1.50 ± 0.04)	MD377775
C	D5-776 (Thickness on tightening: 1.55 ± 0.04)	MD377776

Caution

The cylinder head gasket whose thickness is in size with piston projection is attached. So if you replace the piston or the connecting rod, the piston projection changes. Measure the piston projection, select the cylinder head gasket whose thickness is in size with piston projection should be fitted.

3. Install the cylinder head gasket in order to fit the cylinder head gasket bore to the cylinder head bore.
4. Clean the cylinder head assembly and the cylinder block mating surfaces with a scraper or a wire brush.

Caution

Do not allow foreign material to enter the engine coolant or oil passages and the cylinder.

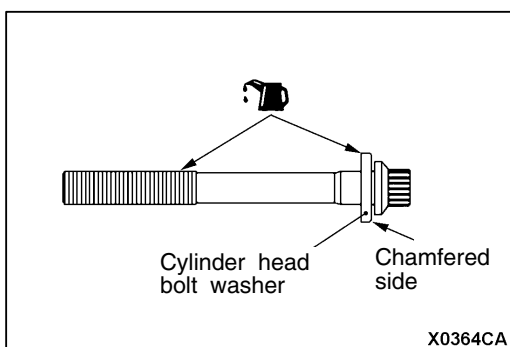

5. Install the cylinder head bolt washer to the cylinder head bolt so that the washer chamfered side faces as shown.
6. Apply a small amount of engine oil to the cylinder head bolt thread and the washer.

7. Tighten the cylinder head bolts according to the following procedure (angle-tightening procedure.)
 - (1) Use the special tool to tighten the cylinder head bolts in the order of the illustrated numbers to 29 ± 2 N·m.

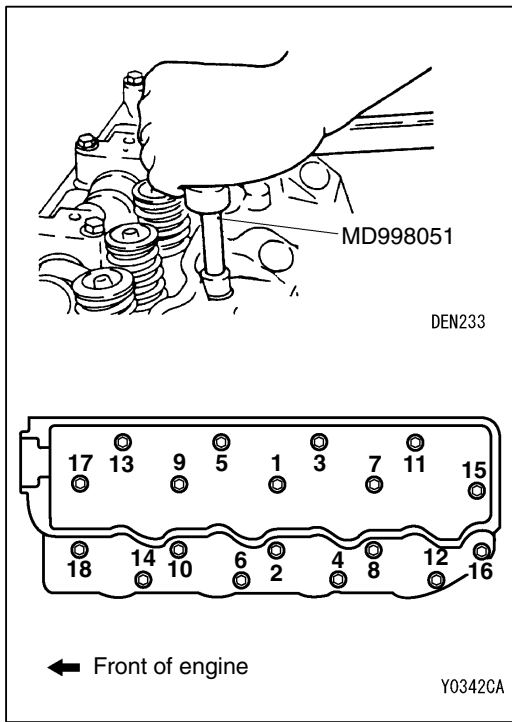

- (2) Place the special tool in a wrench to tighten the cylinder head bolt in the order of the illustrated numbers to 120° .

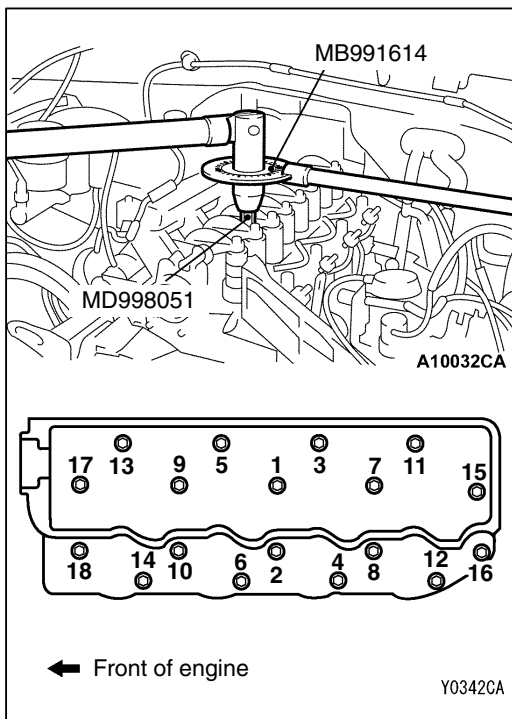

TIMING BELT AND TIMING BELT B <4D56-Step III>**REMOVAL AND INSTALLATION****Pre-removal Operation**

- Cooling Fan Removal (Refer to GROUP 14.)

Post-installation Operation

- Cooling Fan Installation (Refer to GROUP 14.)
- Engine Adjustment

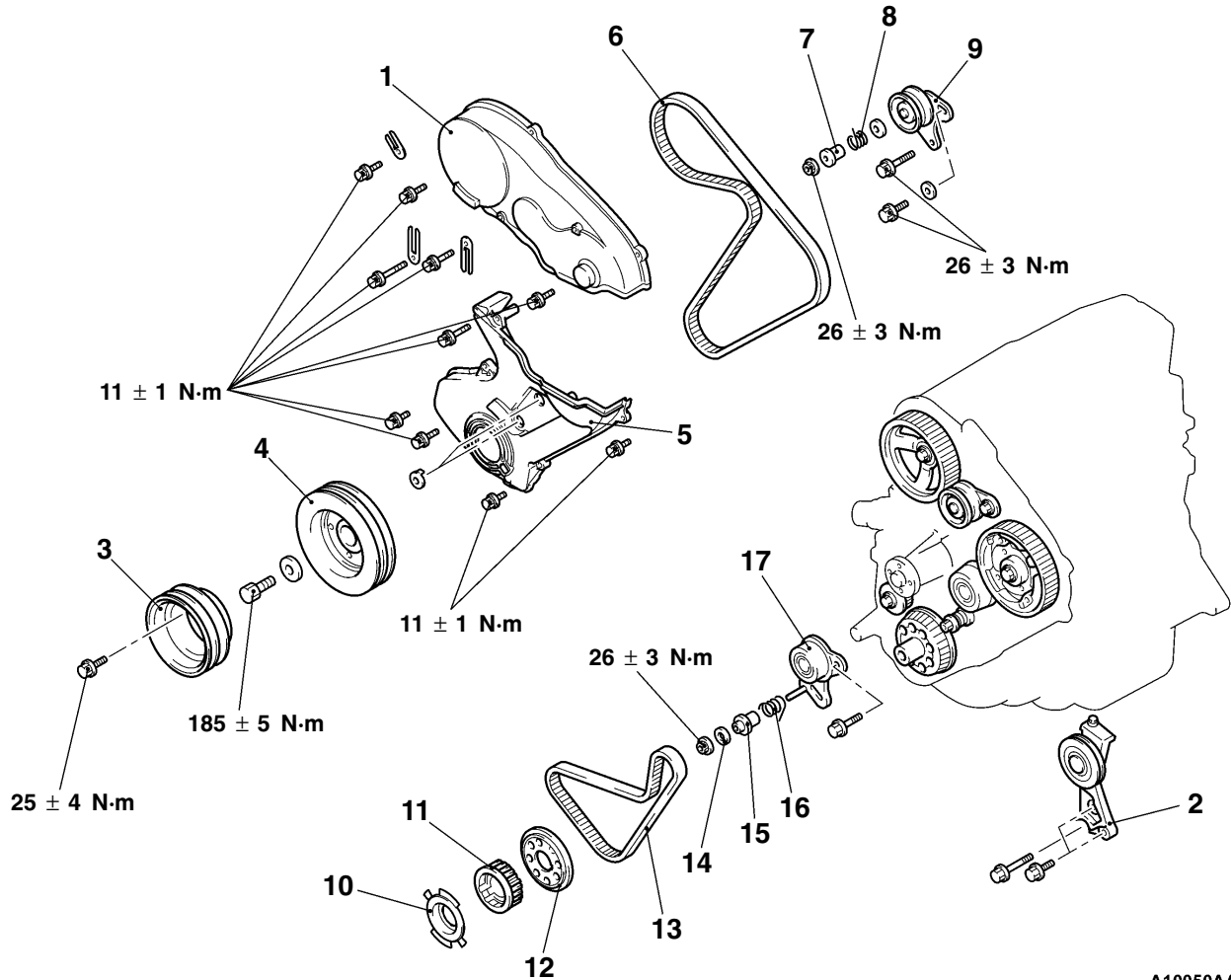

A10050AA

Removal steps

1. Timing belt front upper cover
 2. Tension pulley bracket (for A/C)
 3. Crankshaft pulley (for power steering and A/C)
 4. Crankshaft pulley
 5. Timing belt front lower cover
 6. Timing belt
 7. Tensioner spacer
 8. Tensioner spring
 9. Timing belt tensioner assembly
 10. Crankshaft sensing blade
 11. Crankshaft sprocket
- ◀A▶ ▶C▶
 ▶B▶ ▶B▶

12. Flange
 13. Timing belt B
 14. Gasket
 15. Tensioner spacer B
 16. Tensioner spring B
 17. Timing belt tensioner B
- ▶C▶ ▶A▶

NOTE

Follow the conventional procedures for removal and installation service points.

NOTES