

Painel de Instrumentos

Remoção

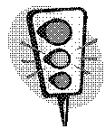

Os módulos eletrônicos são sensíveis às cargas elétricas estáticas. Se forem expostos a essas cargas, danos poderão ocorrer.

CUIDADO

1. Remova a coluna da direção. Para informações adicionais, consulte a [Seção 211-04](#).
2. Remova os parafusos e afaste a alavanca de liberação do freio de estacionamento.

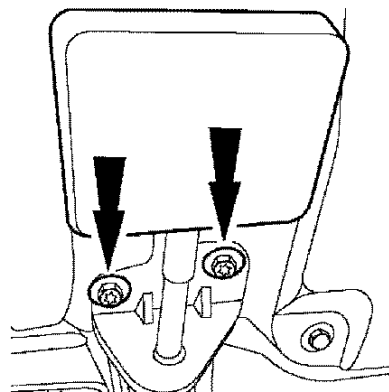

3. Desconecte o conector elétrico do interruptor de posição do pedal do freio (BPP).

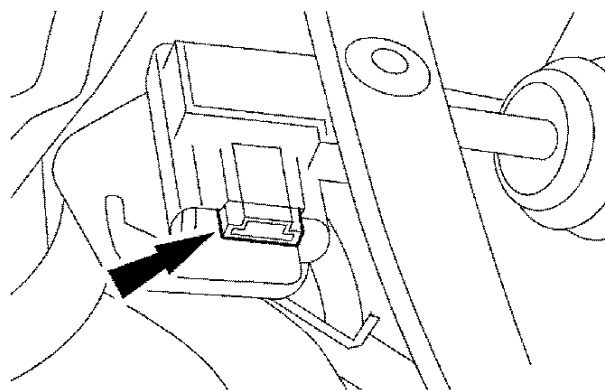

4. Se equipado, desconecte o conector elétrico do interruptor de posição do pedal da embreagem (CPP).

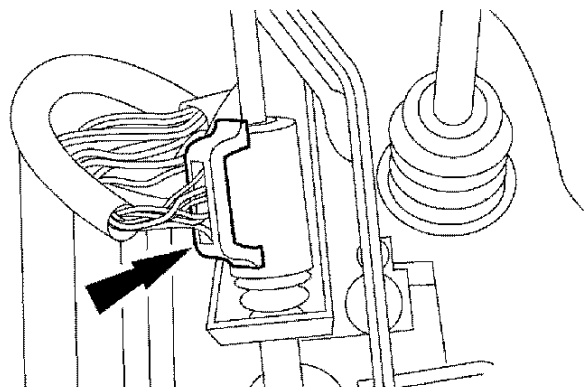

5. Remova as soleiras das portas LD e LE.

1. Remova os oito parafusos.
2. Remova as soleiras das portas LD e LE.

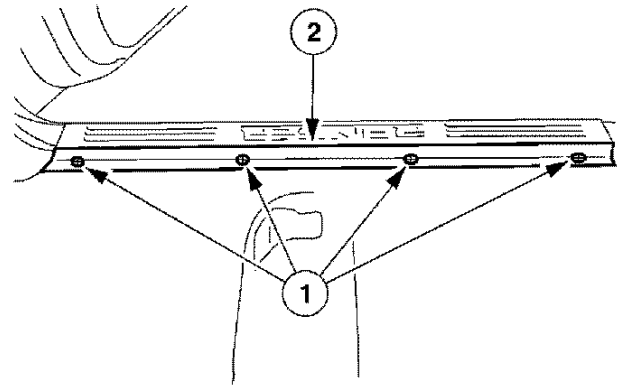

6. Remova os painéis de acabamento inferiores da Coluna-A LD e LE.

- Remova o retentor tipo pino no painel de acabamento do curvão LE.

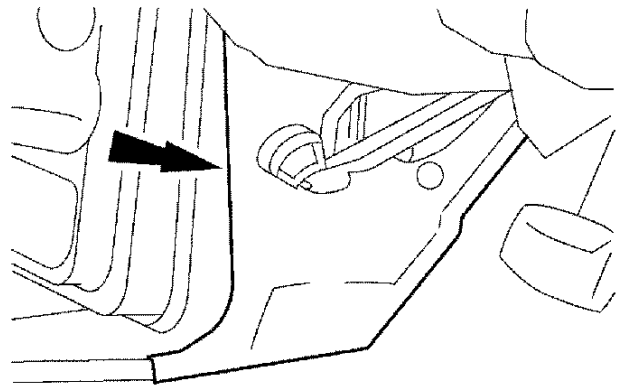

7. Remova as molduras de acabamento laterais do pára-brisa LE e LD.

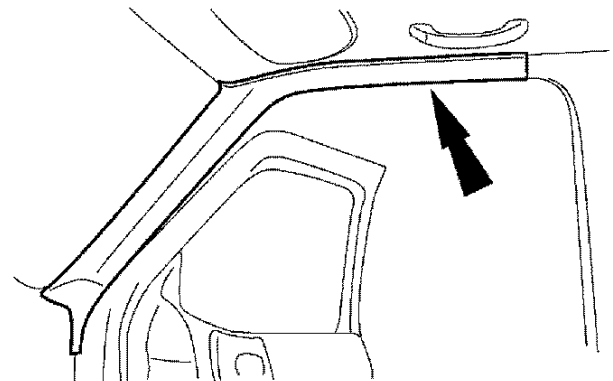

8. Remova o painel de acabamento lateral do painel de instrumentos.

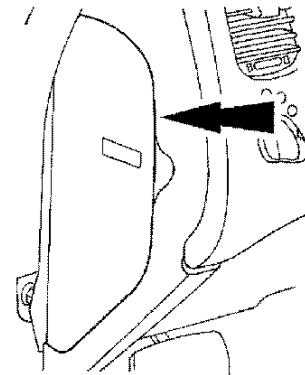

9. Desconecte a central de distribuição da bateria do suporte e afaste-a.

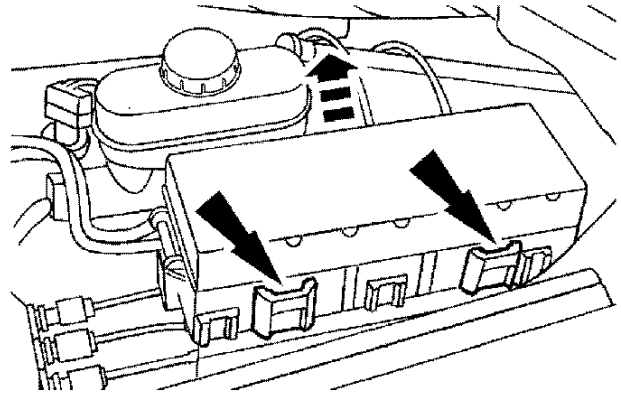

10. Remova o chicote de fiação do anteparo pela parte interna do compartimento do motor.

1. Afrouxe os parafusos.
2. Desconecte os conectores elétricos.

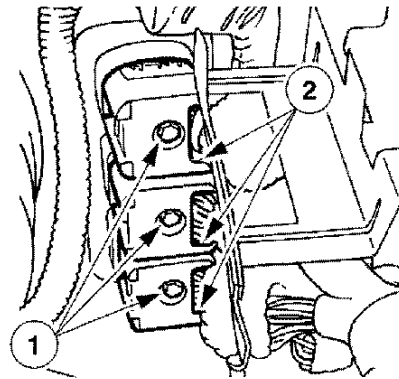

11. Remova a isolamento do conector do anteparo.

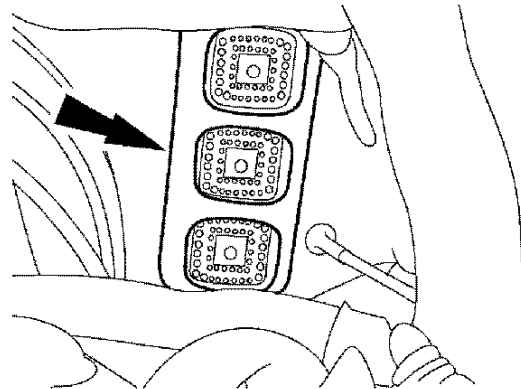

12. Remova a presilha dos conectores elétricos do anteparo do painel do dash.

13. Remova o painel de valência do painel de instrumentos.

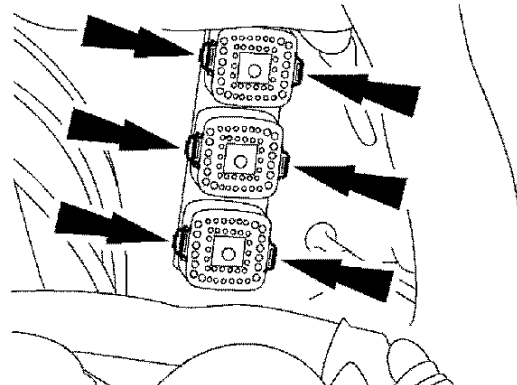

14. Desconecte o conector elétrico do módulo de controle do sistema de segurança (RCM).

1. Remova a lingüeta de travamento.
2. Desconecte o conector elétrico do RCM.

15. Remova o air bag do lado do passageiro. Consulte a Seção 501-20B.

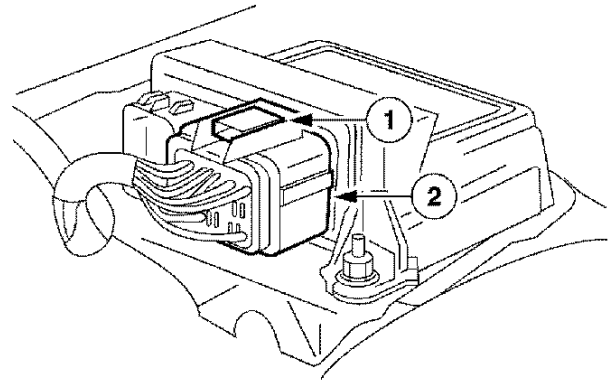

16. Desconecte o conector elétrico do atuador do defletor de mistura.

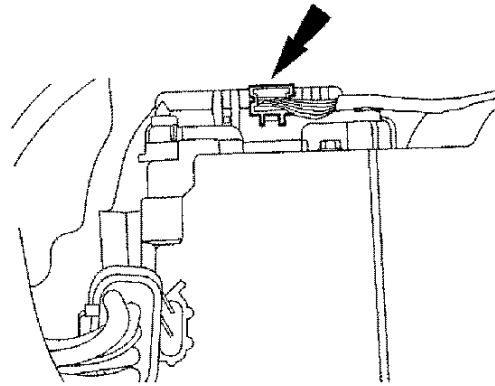

17. Desconecte o conector do chicote de vácuo do controle climático.

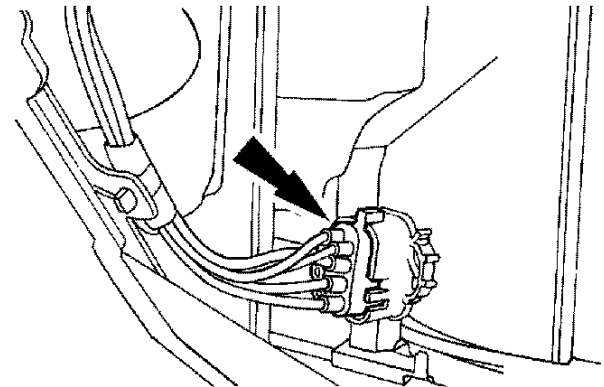

18. Desconecte o conector em-linha do cabo da antena do rádio.

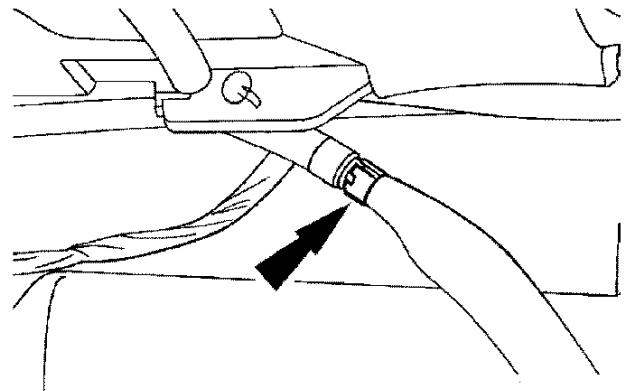

19. Levante e apóie o porta-luvas.

- Pressione a lingüeta de liberação para dentro, levantando ao mesmo tempo o porta-luvas.

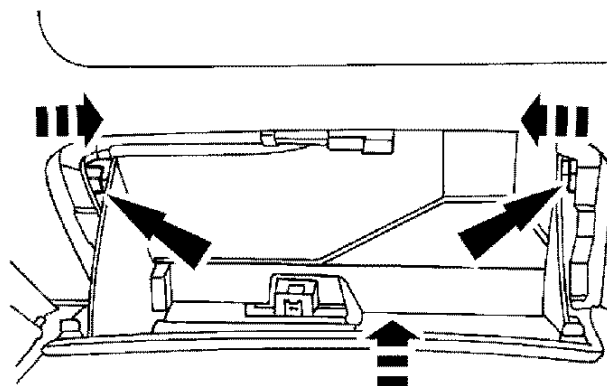

20. Desconecte os conectores elétricos e os fios do terra no painel do curvão LD.

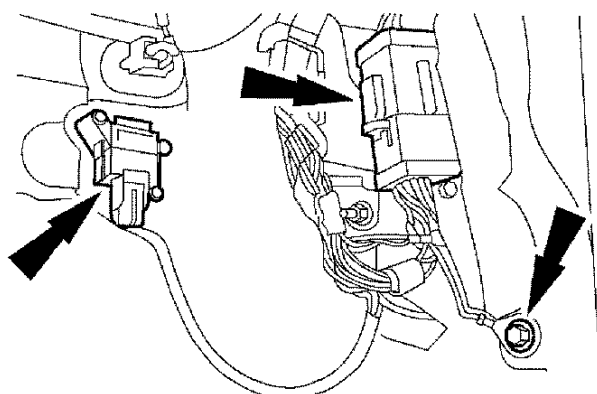

21. Remova a grade da abertura do desembaçador no painel de instrumentos.

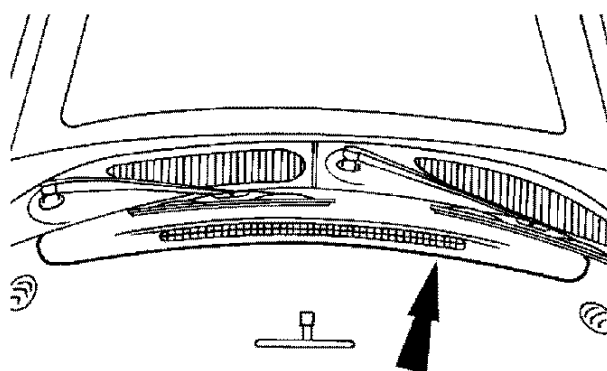

22. Remova os parafusos superiores do curvão no painel de instrumentos.

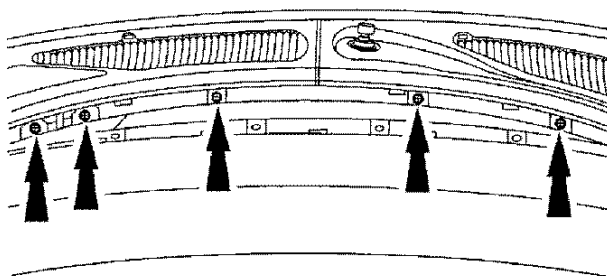

23. Remova o parafuso da braçadeira do painel de instrumentos sob a coluna da direção.

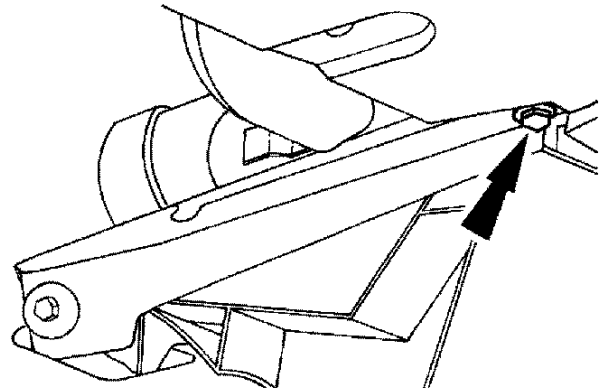

24. Remova o parafuso lateral do curvão LD no painel de instrumentos.

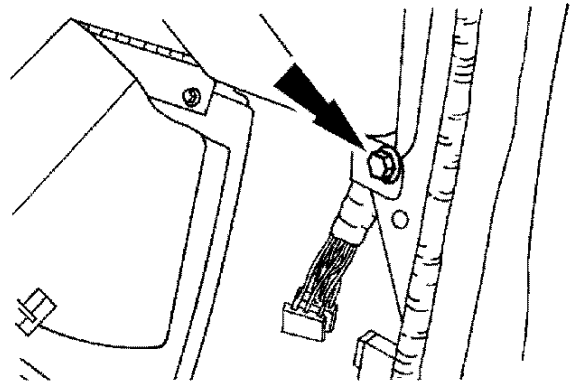

25. Remova os parafusos laterais do curvão LE no painel de instrumentos.

26. Afaste o painel de instrumentos do painel do dash.

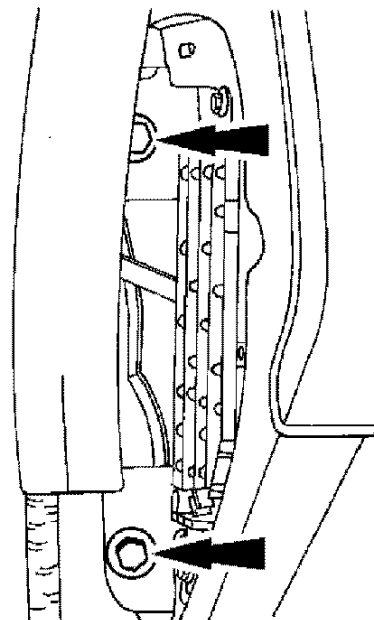

27. Desconecte o painel de instrumentos do chicote da carroceria.

1. Afrouxe o parafuso.
2. Desconecte o chicote.

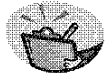

Dois técnicos são necessários para realizar este passo.

NOTA

Remova o painel de instrumentos.

- Se necessário, transfere os componentes para o painel de instrumentos novo.

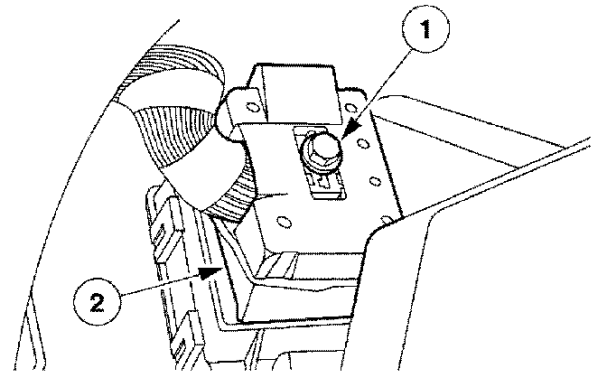

Instalação

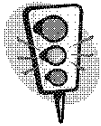

Os módulos eletrônicos são sensíveis às cargas elétricas estáticas. Se forem expostos a essas cargas, danos poderão ocorrer.

CUIDADO



Dois técnicos são necessários para realizar este passo.

NOTA

Posicione o painel de instrumentos.

1. Conecte o painel de instrumentos ao chicote da carroceria.

1. Conecte o chicote.
2. Instale o parafuso.

2. Alinhe e instale o painel de instrumentos.

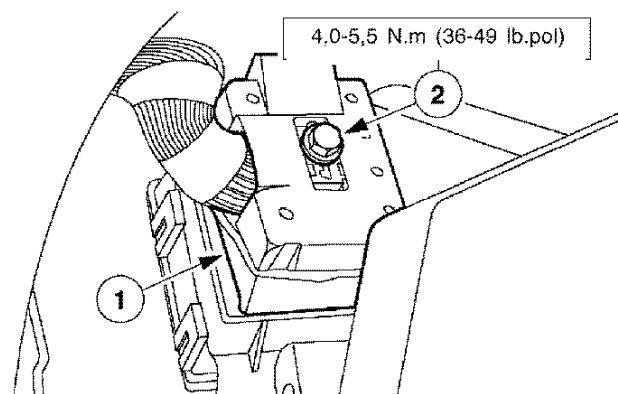

3. Instale os parafusos laterais do curvão LE no painel de instrumentos.

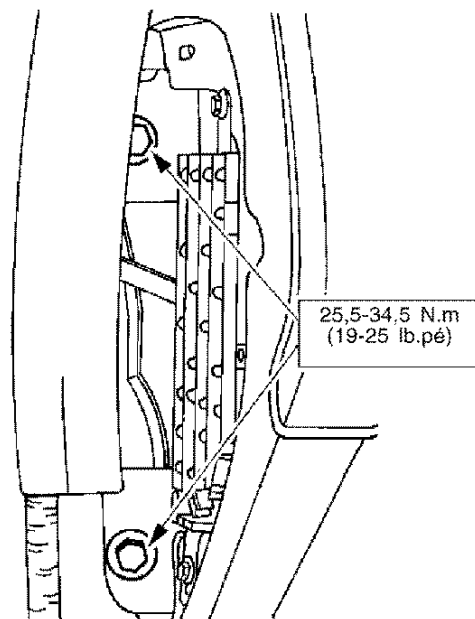

4. Instale o parafuso lateral do curvão LD no painel de instrumentos.

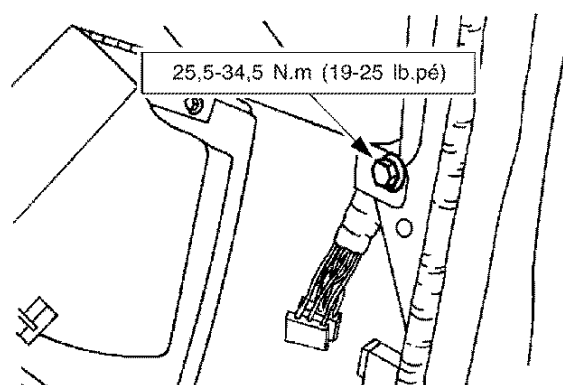

5. Instale os parafusos superiores do curvão no painel de instrumentos.

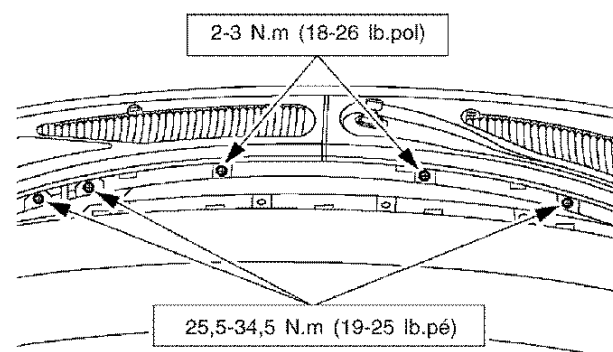

6. Instale a grade da abertura do desembaçador no painel de instrumentos.

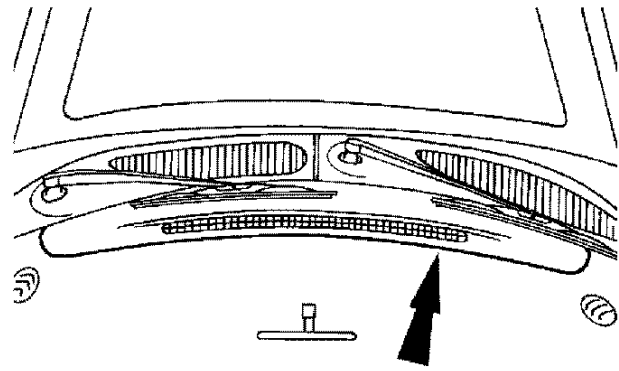

7. Instale o parafuso da braçadeira do painel de instrumentos.

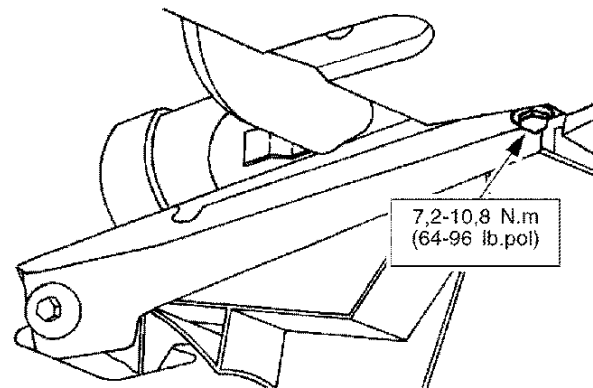

8. Conecte os conectores elétricos e os fios do terra no painel do curvão LD.

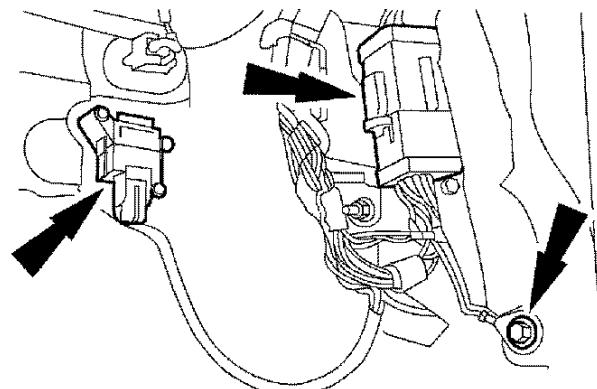

9. Abaixe o porta-luvas.

- Pressione as lingüetas de liberação do porta-luvas, e ao mesmo tempo empurrando para baixo o porta-luvas.

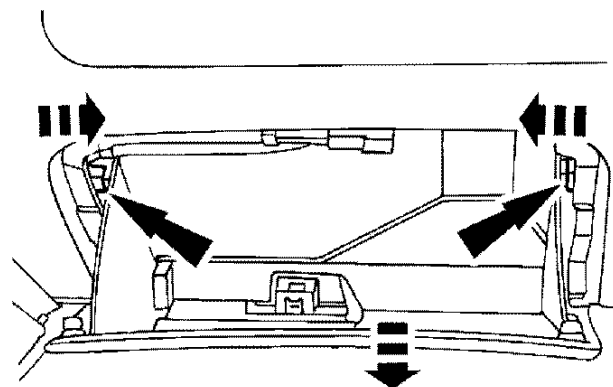

10. Conecte o conector em-linha do cabo da antena do rádio.

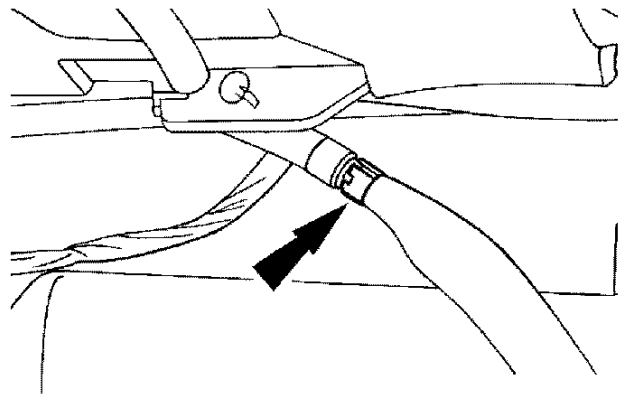

11. Conecte o conector do chicote de vácuo controle climático.

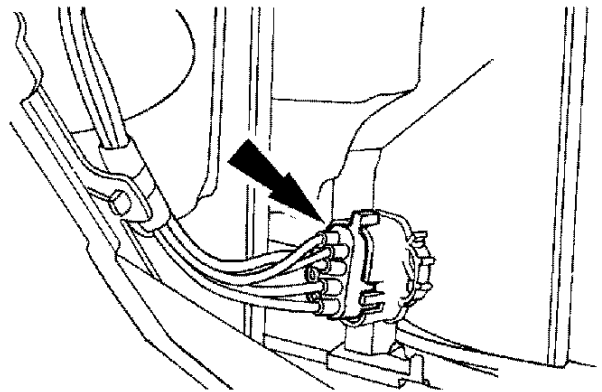

12. Conecte o conector elétrico do atuador do defletor de mistura.

13. Instale o módulo do air bag do lado do passageiro.
 Consulte a [Seção 501-20B](#).

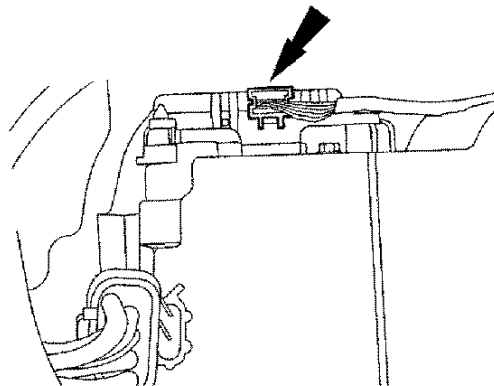

14. Conecte o conector elétrico do RCM.

1. Instale o conector elétrico do RCM.
2. Encaixa a presilha de travamento.

15. Instale o painel de valência do painel de instrumentos.

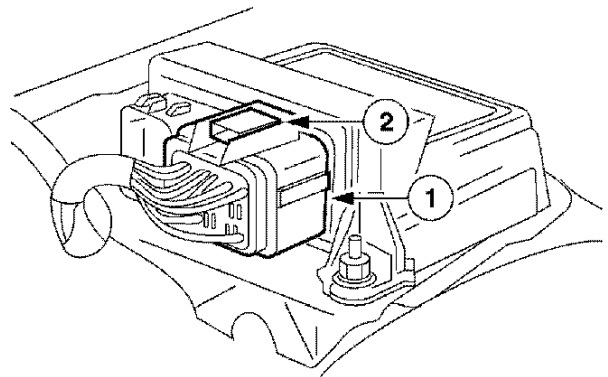

16. Posicione a manopla do conector elétrico do anteparo.

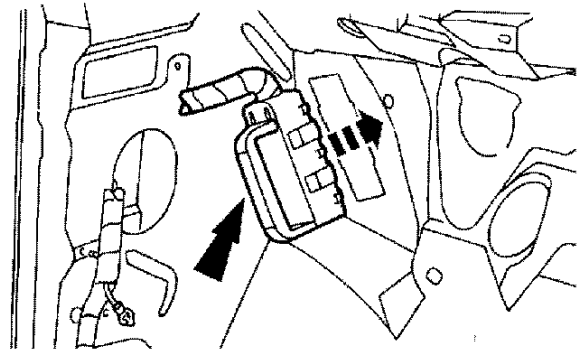

17. Conecte o conector elétrico do interruptor do BPP.

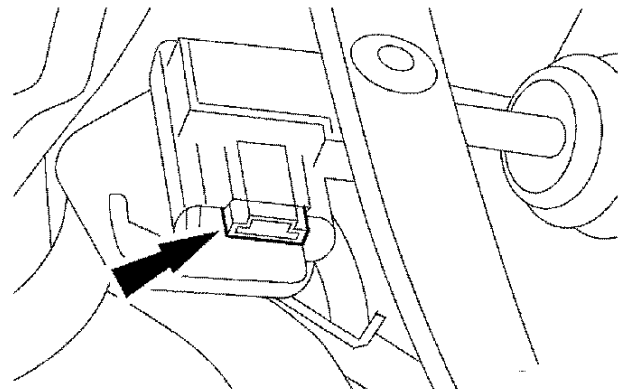

18. Conecte o conector elétrico do interruptor do CPP.

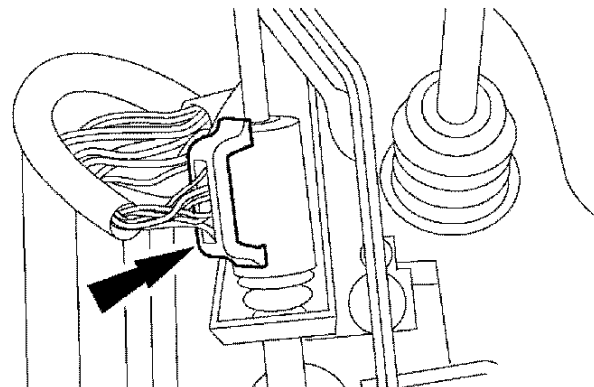

19. Instale a isolação do conector do anteparo.

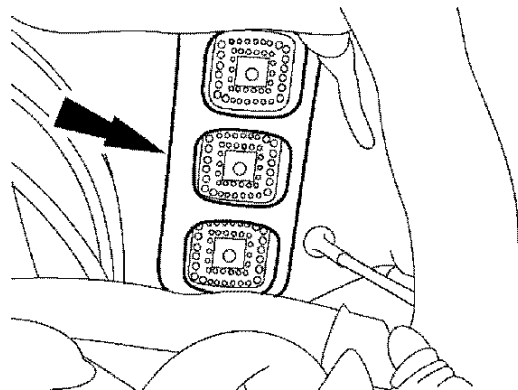

20. Instale os conectores do chicote de fiação do anteparo.

1. Conecte os conectores elétricos.
2. Instale os parafusos.

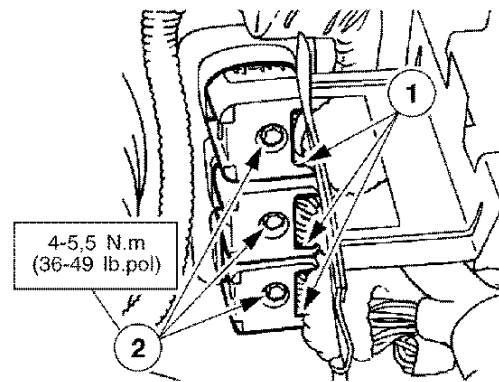

21. Instale a central de distribuição da bateria no suporte.

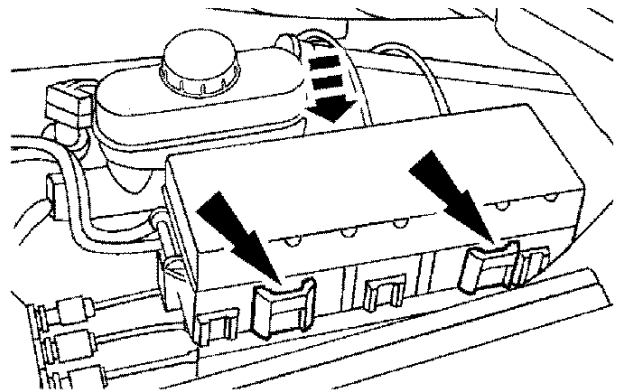

22. Instale os painéis de acabamento inferiores da Coluna-A LD e LE.

- Instale o retentor tipo pino no painel de acabamento do curvão LE.

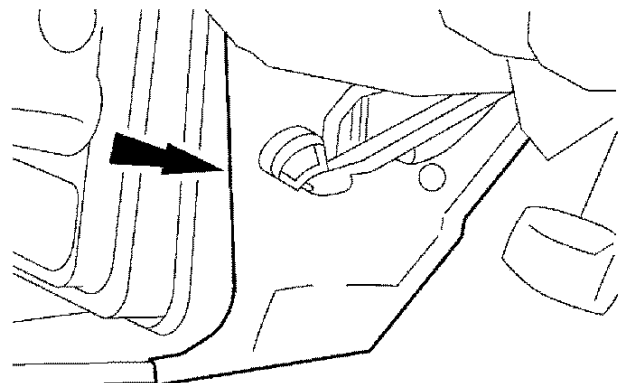

23. Instale as molduras de acabamento laterais do pára-brisa LE e LD.

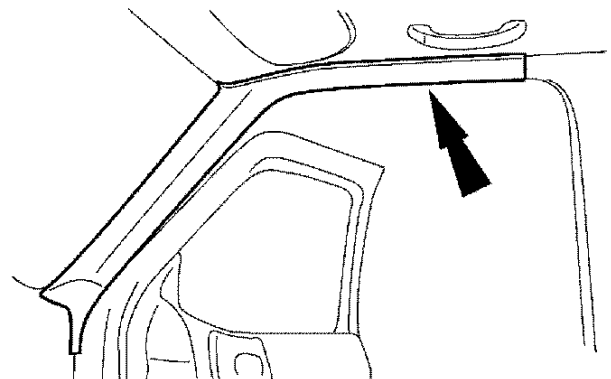

24. Instale as soleiras das portas LD e LE.

1. Posicione as soleiras das portas.
2. Instale os oito parafusos.

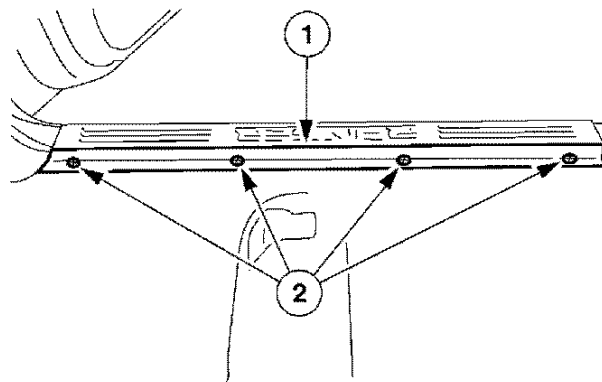

25. Instale o painel de acabamento lateral do painel de instrumentos.

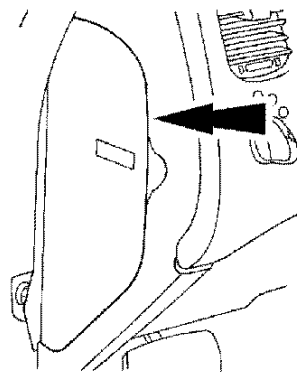

26. Instale a alavanca de liberação do freio de estacionamento.

1. Posicione a alavanca.
2. Instale os parafusos.

27. Instale a coluna de direção. Para informações adicionais, consulte a [Seção 211-04](#).

