



2L-T, 3L

ENGINE

REPAIR MANUAL SUPPLEMENT

Jan., 1990

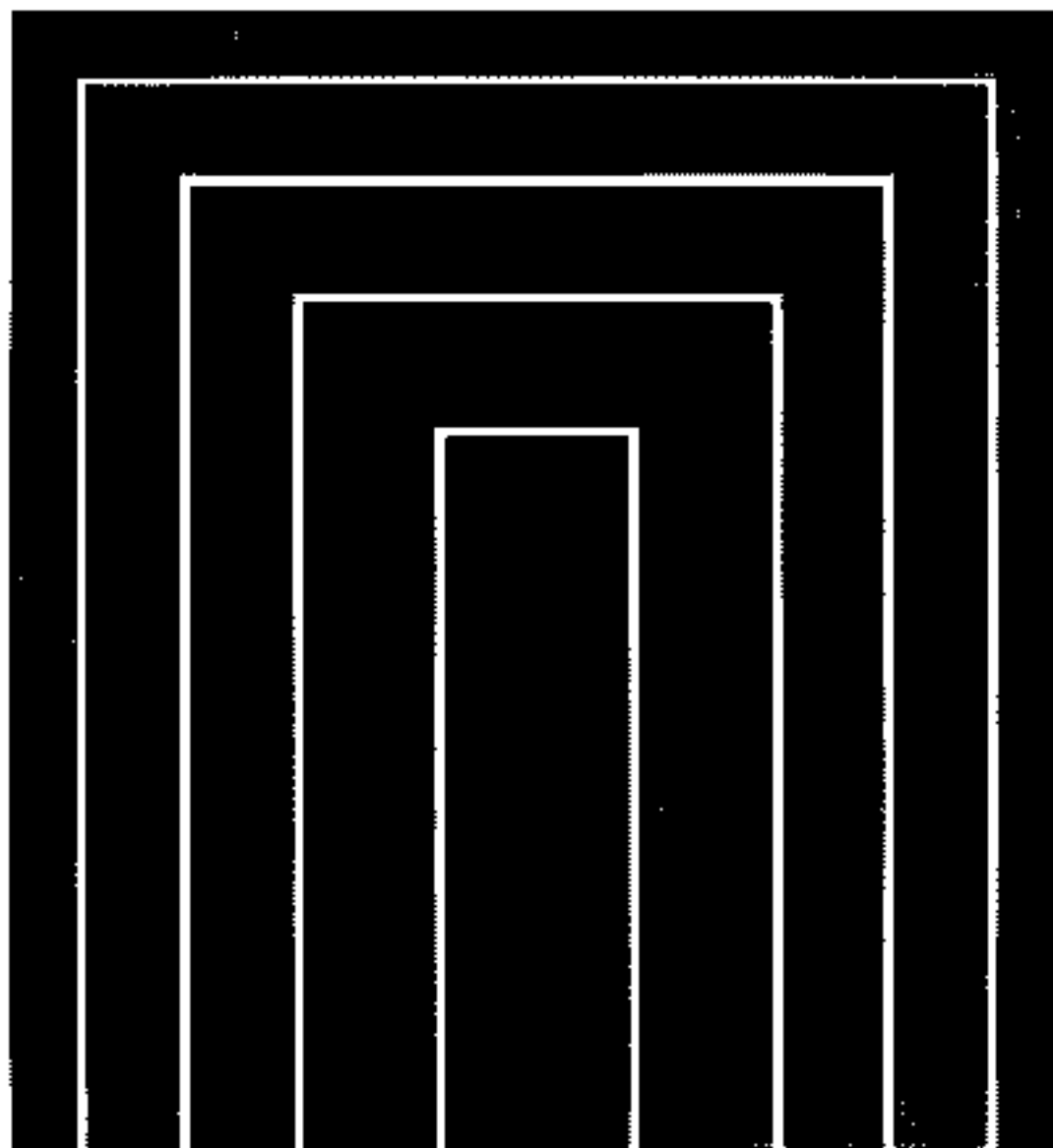

For Europe and General
Pub. No. RM169F

FOREWORD

This supplement has been prepared to provide information covering general service repairs for the 2L-T and 3L engines mounted on the TOYOTA LAND CRUISER, HILUX, and 4RUNNER.

Applicable models:

LJ70, 72, 73, 77, 79 series

LN106, 111, 130, 135 series

For basic engine service repair, refer to the following repair manual.

2L, 3L Engine Repair Manual (Pub. No. RM123E)

Please note that the publications below have also been prepared as relevant service manuals to the components and systems in this engine.

All information contained in this manual is the most up-to-date at the time of publication. However, specifications and procedures are subject to change without notice.

TOYOTA MOTOR CORPORATION

TOYOTA 2L-T, 3L ENGINE REPAIR MANUAL SUPPLEMENT

INTRODUCTION	IN
ENGINE MECHANICAL	EM
TURBOCHARGER SYSTEM	TC
FUEL SYSTEM	FU
COOLING SYSTEM	CO
LUBRICATION SYSTEM	LU
STARTING SYSTEM	ST
CHARGING SYSTEM	CH
SERVICE SPECIFICATIONS	A
STANDARD BOLT TORQUE SPECIFICATIONS	B
SST AND SSM	C

INTRODUCTION

	Page
HOW TO USE THIS MANUAL	IN-2
IDENTIFICATION INFORMATION	IN-4
GENERAL REPAIR INSTRUCTIONS	IN-4
ABBREVIATIONS USED IN THIS MANUAL	IN-7

IN

HOW TO USE THIS MANUAL

To assist you in finding your way through this manual, the Section Title and major heading are given at the top of every page.

An **INDEX** is provided on the 1st page of each section to guide you to the item to be repaired.

At the beginning of each section, **PRECAUTIONS** are given that pertain to *all* repair operations contained in that section.

Read these precautions before starting any repair task.

TROUBLESHOOTING tables are included for each system to help you diagnose the problem and find the cause. The repair for each possible cause is referenced in the remedy column to quickly lead you to the solution.

REPAIR PROCEDURES

Most repair operations begin with an overview illustration. It identifies the components and shows how the parts fit together.

Example:

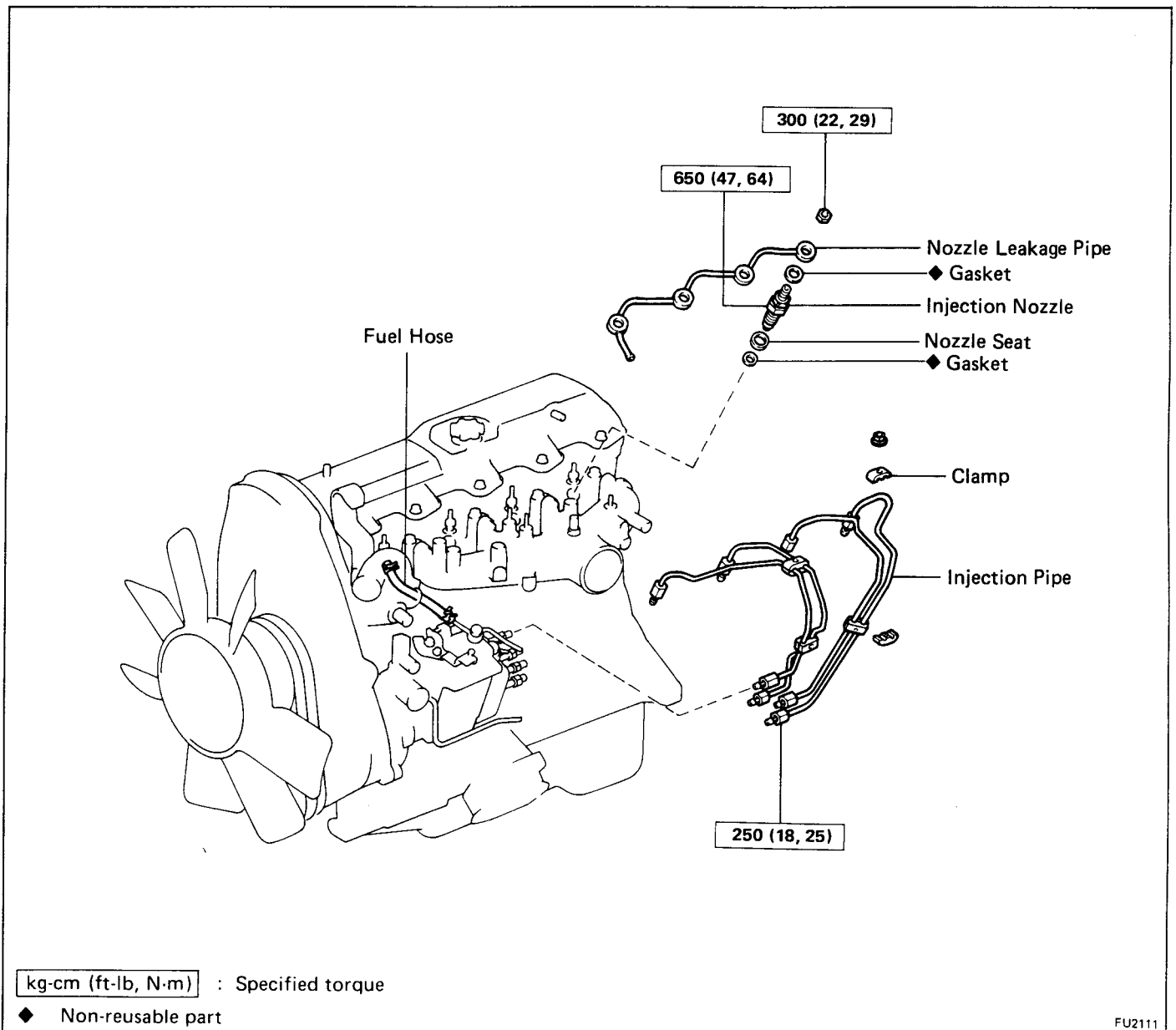

The procedures are presented in a step-by-step format:

- The illustration shows *what* to do and *where* to do it.
- The task heading tells *what* to do.
- The detailed text tells *how* to perform the task and gives other information such as specifications and warnings.

Example:

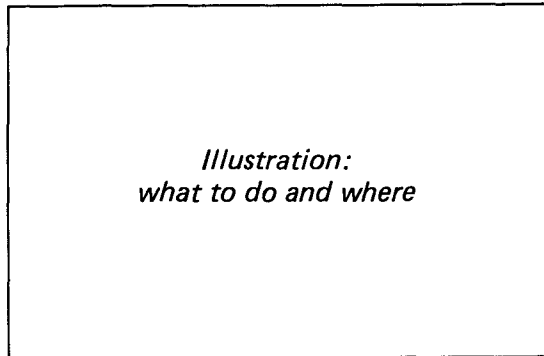

Task heading: what to do

REMOVE CRANKSHAFT PULLEY

Using SST, remove the pulley.

SST 09213-60017 (09213-00060)

Set part No. *Component part No.*

Detailed text: how to do task

Install the four injection nozzles.

Torque: 650 kg-cm (47 ft-lb, 64 N·m)

Specification

This format provides the experienced technician with a FAST TRACK to the information needed. The upper case task heading can be read at a glance when necessary, and the text below it provides detailed information. Important specifications and warnings always stand out in bold type.

REFERENCES

References have been kept to a minimum. However, when they are required, you are given the page to refer to.

SPECIFICATIONS

Specifications are presented in bold type throughout the text where needed. You never have to leave the procedure to look up your specifications. They are also found in Appendix A for quick reference.

CAUTIONS, NOTICES, HINTS:

- **CAUTIONS** are presented in bold type, and indicate there is a possibility of injury to you or other people.
- **NOTICES** are also presented in bold type, and indicate the possibility of damage to the components being repaired.
- **HINTS** are separated from the text but do not appear in bold. They provide additional information to help you efficiently perform the repair.

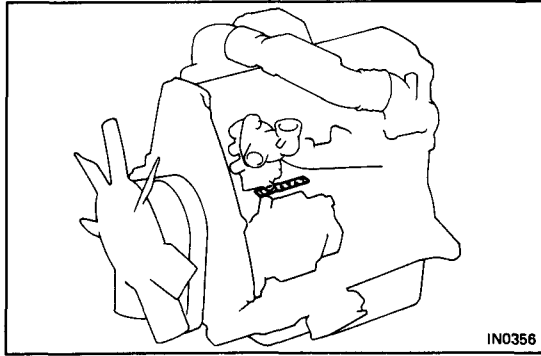

IDENTIFICATION INFORMATION

ENGINE SERIAL NUMBER

The engine serial number is stamped on the left side of the cylinder block.

GENERAL REPAIR INSTRUCTIONS

1. Use fender, seat and floor covers to keep the vehicle clean and prevent damage.
2. During disassembly, keep parts in order to facilitate reassembly.
3. Observe the following.
 - (a) Before performing electrical work, disconnect the negative (–) cable from the battery terminal.
 - (b) If it is necessary to disconnect the battery for inspection or repair, always disconnect the cable from the negative (–) terminal which is grounded to the vehicle body.
 - (c) To prevent damage to the battery terminal post, loosen the terminal nut and raise the cable straight up without twisting or prying it.
 - (d) Clean the battery terminal posts and cable terminals with a shop rag. Do not scrape them with a file or other abrasive object.
 - (e) Install the cable terminal to the battery post with the nut loose, and tighten the nut after installation. Do not use a hammer to tap the terminal onto the post.
 - (f) Be sure the cover for the positive (+) terminal is properly in place.
4. Check hose and wiring connectors to make sure that they are secure and correct.
5. Non-reusable parts
 - (a) Always replace cotter pins, gaskets, O-rings, oil seals, etc. with new ones.
 - (b) Non-reusable parts are indicated in the component illustrations by the "◆" symbol.
6. Precoated parts

Precoated parts are bolts and nuts, etc. These are coated with a seal lock adhesive at the factory.

 - (a) If a precoated part is retightened, loosened or caused to move in any way, it must be recoated with the specified adhesive.

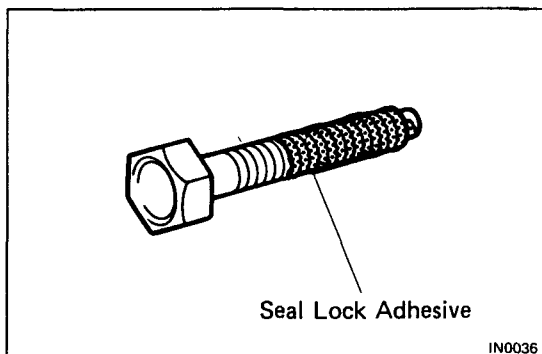

- (b) Recoating of Precoated Parts
 - (1) Clean off the old adhesive from the part's threads.
 - (2) Dry with compressed air.
 - (3) Apply the specified seal lock adhesive to the part's threads.
 - (c) Precoated parts are indicated in the component illustrations by the "★" symbol.
7. When necessary, use a sealer on gaskets to prevent leaks.
 8. Carefully observe all specifications for bolt torques. Always use a torque wrench.
 9. Use of special service tools (SST) and special service materials (SSM) may be required, depending on the nature of the repair. Be sure to use SST and SSM where specified and follow the proper work procedure. A list of SST and SSM can be found at the back of this manual.
 10. When replacing fuses, be sure the new fuse is the correct amperage. **DO NOT** exceed the rating or use one of a lower rating.
 11. Care must be taken when jacking up and supporting the vehicle. Be sure to lift and support the vehicle at the proper locations.
 - (a) If the vehicle is to be jacked up only at the front or rear end, be sure to block the wheels in order to ensure safety.
 - (b) After the vehicle is jacked up, be sure to support it on stands. It is extremely dangerous to do any work on the vehicle raised on a jack alone, even for a small job that can be finished quickly.
 12. Observe the following precautions to avoid damaging the parts:
 - (a) Be careful not to drop electrical components, such as sensors or relays. If they are dropped on a hard floor, they should be replaced and not reused.

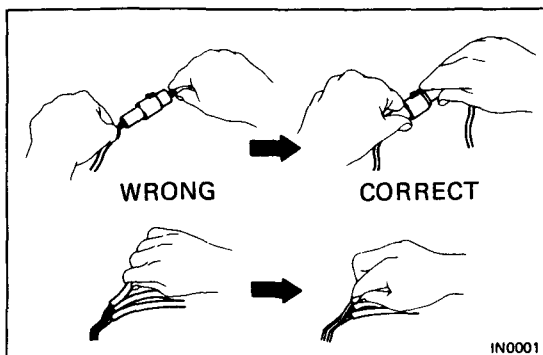

- (b) When separating electrical connectors, pull on the connector itself, not the wires.
- (c) When disconnecting vacuum hoses, pull on the end of the hose, not the middle.

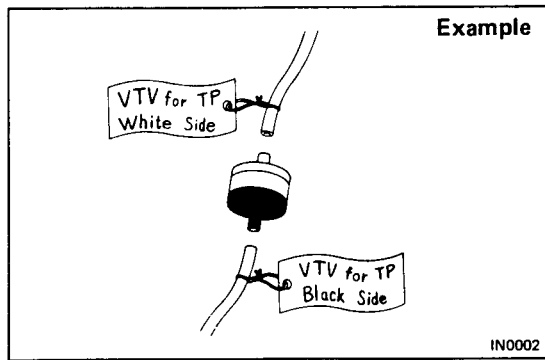

- (d) When steam cleaning an engine, protect the distributor, coil, air filter, and injection pump from water.
 - (e) Never use an impact wrench to remove or install temp. switches or temp. sensors.
 - (f) When checking continuity at the wire connector, insert the tester probe carefully to prevent terminals from bending.
 - (g) When using a vacuum gauge, never force the hose onto a connector that is too large. Use a step-down adapter instead. Once the hose has been stretched, it may leak.
13. Tag hoses before disconnecting them:
- (a) When disconnecting vacuum hoses, use tags to identify how they should be reconnected.
 - (b) After completing a job, double check that the vacuum hoses are properly connected. A label under the hood shows the proper layout.

ABBREVIATIONS USED IN THIS MANUAL

A/C	Air Conditioner
ACSD	Automatic Cold Start Device
Approx.	Approximately
EGR	Exhaust Gas Recirculation
EVRV	Electronic Vacuum Regulating Valve
EX	Exhaust (manifold, valve)
Ex.	Except
FIPG	Formed in Place Gasket
FL	Fusible Link
HAC	High Altitude Compensation
IN	Intake (manifold, valve)
LH	Left-Hand
O/S	Oversized
PIJ	Pilot Injection Device
RH	Right-Hand
SSM	Special Service Materials
SST	Special Service Tools
STD	Standard
TDC	Top Dead Center
U/S	Undersize
VSV	Vacuum Switching Valve
w/	With
w/o	Without

ENGINE MECHANICAL

REFER TO 2L, 3L ENGINE REPAIR MANUAL
(Pub. No. RM123E)

NOTE: The following pages contain only the points which differ from the above listed manual.

	Page
DESCRIPTION	EM-2
TROUBLESHOOTING	EM-4
Diesel Engine Diagnosis	EM-4
Diesel Electrical System Diagnosis [2L-T Austria]	EM-13
Diesel Electrical System Diagnosis [2L-T Others]	EM-16
ENGINE TUNE-UP	EM-18
INTAKE VENTURI SYSTEM (LN 2L-T only)	EM-30
COMPRESSION CHECK	EM-33
CYLINDER HEAD (2L-T)	EM-35
CYLINDER BLOCK	EM-46

EM

DESCRIPTION

The 2L-T engine is an in-line 4-cylinder 2.4 liter OHC engine.

The 3L engine is an in-line 4-cylinder 2.8 liter OHC engine.

2L-T

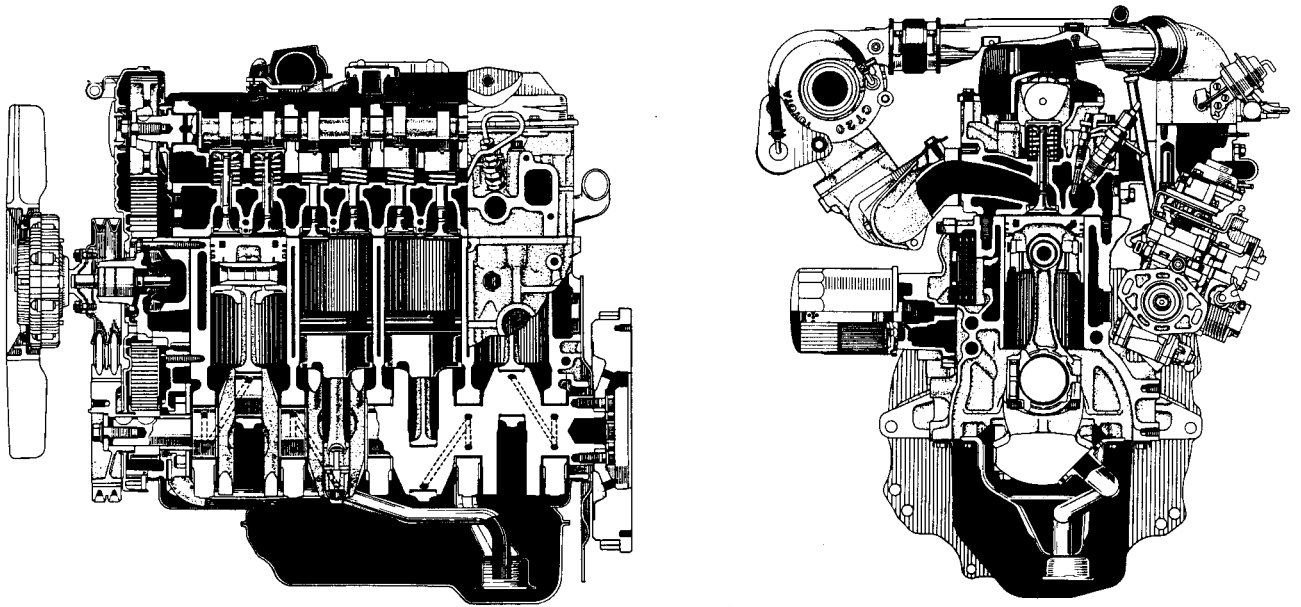

3L

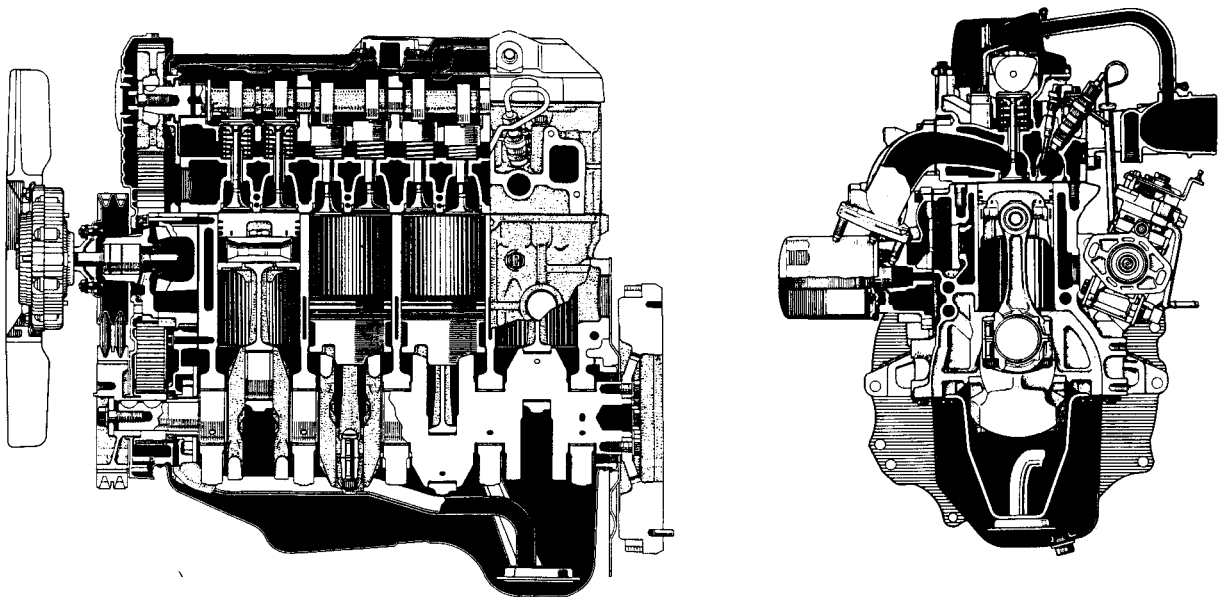

The 2L-T and 3L engines are in-line 4-cylinder engines with the cylinders numbered 1 – 2 – 3 – 4 from the front. The crankshaft is supported by 5 bearings on the inside of the crankcase. These bearings are made of aluminum. The crankshaft is integrated with 8 weights which are cast along with it for balancing. Oil holes are built into the center of the crankshaft for supplying oil to the connecting rods.

This engine's injection order is 1 – 3 – 4 – 2. The cylinder head is made of cast iron with a cross flow type intake and exhaust layout and with swirl type combustion chambers. The glow plugs are located in the combustion chambers.

Exhaust and intake valves are equipped with irregular pitch springs which are capable of following the valves even at high engine speeds.

The camshaft is driven by the timing belt. There are 2 types of camshaft bearing, No. 1 and No. 2. No. 1 bearing is integrated with the thrust washer. The camshaft journal is supported at 5 places between the valve lifters of each cylinder and on the cylinder head of front end. Lubrication of the camshaft journal and cam is accomplished by oil being supplied through the oiler port in the No. 1 camshaft journal.

Adjustment of the valve clearance is done by means of an outer shim type system, in which valve adjusting shims are located above the valve lifters. This permits replacement of the shims without removal of the camshafts.

Pistons are made of highly temperature-resistant aluminum alloy.

Piston pins are the full-floating type, with the pins fastened to neither the piston boss nor the connecting rods. Instead, snap rings are fitted on both ends of the pins, preventing the pins from falling out.

The No. 1 compression ring is made of steel and the No. 2 compression ring is made of cast iron. The oil ring is made of steel. The outer diameter of each piston ring is slightly larger than the diameter of the piston and the flexibility of the rings allows them to hug the cylinder walls when they are mounted on the piston. Compression rings No. 1 and No. 2 work to prevent the leakage of gas from the cylinder and the oil ring works to scrape oil off the cylinder walls to prevent it from entering the combustion chamber.

The cylinder block is made of cast iron. It has 4 cylinders which are approximately 2 times the length of the piston stroke. The top of each cylinder is closed off by the cylinder head and the lower end of cylinder becomes the crankcase, in which the crankshaft is installed. In addition, the cylinder block contains a water jacket, through which coolant is pumped to cool the cylinders.

The oil pan is bolted onto the bottom of the cylinder block. The oil pan is an oil reservoir made of pressed steel sheet. A dividing plate is included inside the oil pan to keep sufficient oil in the bottom of the pan even when the vehicle is tilted. This dividing plate also prevents the oil from making waves when the vehicle is stopped suddenly and thus shifting the oil away from the oil pump suction pipe.

TROUBLESHOOTING

Diesel Engine Diagnosis

GENERAL

1. Diesel engine problems are usually caused by the engine or fuel system. The injection pump is very rarely the cause of fuel system problems.
2. Before beginning fuel system tests, first check that the engine compression, valve timing and other major systems are within specifications.

PRELIMINARY CHECKS

1. Before performing fuel system checks, ensure that the engine is in good running condition. If necessary, first check the compression, timing and major components or systems.
2. Check the air filter, and clean or replace it if necessary.
3. Check that there is sufficient fuel in the tank.
4. Check if the fuel is contaminated with gasoline or other foreign elements. Only good-quality diesel fuel should be used.
5. Bleed air from the system by pumping the priming.
6. Check for water in the fuel filter and fuel tank, and drain as necessary.
7. If the engine will not crank or if it cranks slowly, first troubleshoot the electrical system.

PRECAUTION:

1. The basic troubleshooting procedures for the diesel engine (valve clearance, compression, bearings, valves, pistons, etc.) are the same checks you would make for gasoline engine.
2. Repair of the injection pump requires considerable skill and use of a special test bench.

ENGINE WILL NOT CRANK**(Possible Cause)****(Check Procedure and Correction Method)**

1. LOOSE OR CORRODED BATTERY CABLES	Check cables from battery to starter and make necessary repairs.
2. DISCHARGED BATTERY	Check alternator output and drive belt. If necessary, repair. (See page CH-3)
3. INOPERATIVE STARTER	Check for battery voltage at starter terminals 30 and 50. If okay, see STARTING SYSTEM for repair procedure.

ENGINE CRANKS SLOWLY-WILL NOT START

HINT: Minimum cranking speed:

Cold 100 rpm
Hot 150 rpm

(Possible Cause)**(Check Procedure and Correction Method)**

1. LOOSE OR CORRODED BATTERY CABLES	Check cables from battery to starter and make necessary repairs.
2. DISCHARGED BATTERY	Check alternator output and drive belt. If necessary, repair. (See page CH-3)
3. IMPROPER ENGINE OIL	Check engine oil. If improper viscosity, drain and refill with oil of viscosity recommended by manufacturer. (See page LU-4)

ENGINE CRANKS NORMALLY BUT WILL NOT START**(Possible Cause)****(Check Procedure and Correction Method)****1. NO FUEL TO NOZZLE**

Loosen any one injection pipe union nut from its nozzle holder.

Crank engine for about 5 seconds while confirming that fuel is being discharged from pipe.

If fuel is coming out, begin diagnosis from item 4.

If not, begin from item 2.

2. NO FUEL CUT SOLENOID OPERATION

With starter switch turned ON, check for fuel cut solenoid operation noise (clicking sound) while repeatedly connecting and disconnecting fuel cut solenoid.

If no noise, check if there is battery voltage to solenoid when starter switch is ON.

If battery voltage is confirmed, fuel cut solenoid is faulty and should be replaced. If no voltage, refer to ELECTRICAL DIAGNOSIS and make necessary repairs.

3. NO FUEL INTO INJECTION PUMP

Disconnect inlet hoses from fuel filter, and feed clean fuel from separate container directly into fuel pump.

HINT: When feeding fuel tank directly into pump, keep container at same level as vehicle fuel tank.

If engine starts, either fuel filter or line between fuel tank and filter is clogged and should be repaired accordingly.

If engine still does not start (no fuel intake), check fuel line between filter and pump.

If normal, pump is faulty and should be replaced.

4. FUEL LEAKAGE FROM INJECTION PIPES

Check for loose unions or cracks.

If leaking, tighten to standard torque or, if necessary, replace pipe(s).

5. INOPERATIVE PRE-HEATING OPERATION

With starter switch turned ON and glow plug indicator light illuminated, check that there is voltage applied to glow plug.

If not, refer to ELECTRICAL DIAGNOSIS and repair as necessary.

6. FAULTY GLOW PLUG OPERATION

Check glow plug for continuity.

If no continuity, a broken wire is indicated and glow plug should be replaced.

7. IMPROPER INJECTION TIMING

Check injection timing. (See page EM-24 or 25)

Plunger stroke:

2L-T (Austria) Within the marks of belt case and pump flange. (See page EM-24)

2L-T (Others) 0.54 – 0.66 mm
(0.0213 – 0.0260 in.)

3L 0.84 – 0.96 mm
(0.0331 – 0.0378 in.)

If not as above, injection pump is improperly adjusted.

**8. (2L-T)
IMPROPER COLD START
ADVANCE AND FAST IDLE**

Check timer piston stroke and fast idle lever opening angle with an injection pump tester when cold start advance is operated.

9. FAULTY INJECTION NOZZLES

Check injection pressure with a nozzle tester.

Opening pressure: 145 – 155 kg/cm²
(2,062 – 2,205 psi)
(14,220 – 15,200 kPa)

If not as above, nozzle adjustment is improper and pressure should be readjusted.

If pressure cannot be adjusted to specification, replace injection nozzle.

ROUGH IDLE WITH WARM ENGINE

(Possible Cause)

(Check Procedure and Correction Method)

1. IMPROPER ADJUSTMENT OF ACCELERATOR CABLE

With accelerator pedal released, check that adjusting lever is in contact with idle speed adjusting screw. Also check if accelerator cable or linkage is catching on something.

If necessary, adjust so that lever is in contact with screw, or make other required repairs.

2. IDLE SPEED TOO LOW

Check idle speed. (See page EM-27)

Idle speed: 2L-T 700 – 800 rpm
3L 650 – 750 rpm

HINT: If less than standard, idling would normally be rough.

If not as above, adjust with idle speed adjusting screw.

3. FUEL LEAKAGE

Check for leaks at injection pump connections, pump distributive head bolt, injection nozzles and delivery valve holders.

Tighten any loose connections to specified torque or replace parts as necessary.

4. IMPROPER INJECTION TIMING

Refer to step 7 of ENGINE CRANKS NORMALLY BUT WILL NOT START, above.

5. IMPROPER OPERATION OF INJECTION NOZZLES OR DELIVERY VALVES

With engine idling, loosen injection pipe to each cylinder in order, and check if idle speed changes.

If no change, a faulty cylinder is indicated. Check according to following procedure.

- Faulty injection nozzle

Check injection nozzle with a nozzle tester.

Opening pressure: 145 – 155 kg/cm²
(2,062 – 2,205 psi)
(14,220 – 15,200 kPa)

If not as above, nozzle adjustment is improper and pressure should be readjusted.

If pressure cannot be adjusted to specification, replace injection nozzle.

- Faulty delivery valve

If injection pressure is as specified, delivery valve is defective and should be replaced.

ENGINE SUDDENLY STOPS

(Possible Cause)

(Check Procedure and Correction Method)

1. ENGINE WILL NOT RE-START

Check to see if engine re-starts according to prescribed procedure.

If not, refer to **ENGINE CRANKS NORMALLY BUT WILL NOT START**, above, and repair as necessary.

2. ROUGH IDLE

Refer to **ROUGH IDLE WITH WARM ENGINE** and repair accordingly.

3. MALFUNCTION OF FUEL CUT SOLENOID

Refer to **ENGINE CRANKS NORMALLY BUT WILL NOT START**, above, and check accordingly.

HINT: No operation noise from fuel cut solenoid may be due to loose electrical connections, so check connectors before proceeding with further repairs.

4. NO FUEL INTO INJECTION PUMP

Refer to step 3 of **ENGINE CRANKS NORMALLY BUT WILL NOT START**, above.

LACK OF POWER

HINT:

- First check that the air cleaner is not clogged or the engine overheating.
- Not applicable if the customer desires an output power higher than specified for that vehicle. For accuracy, adjust with a chassis dynamo.

(Possible Cause)

(Check Procedure and Correction Method)

1. IMPROPER ADJUSTMENT OF ACCELERATOR CABLE

With accelerator fully depressed, check that adjusting lever is in contact with maximum speed adjusting screw. Also check if accelerator cable or linkage is catching on something.

If necessary, adjust so that lever is in contact with screw, or make other required repairs.

2. INSUFFICIENT MAXIMUM SPEED

Check maximum speed. (See page EM-27)

Maximum speed:

2L-T 4,700 – 4,900 rpm

3L (Hong Kong, Singapore and Malaysia)

 4,300 – 4,500 rpm

3L (Others) 4,500 – 4,700 rpm

If not as above, adjust with maximum speed adjusting screw.

3. INTERCHANGED OVERFLOW SCREW (OUT) AND INLET (NO MARK) FITTING	HINT: Overflow screw is marked "OUT" and has an inner jet. Although both fittings are same size, they must not be interchanged.
4. FUEL LEAKAGE	Refer to step 3 of ROUGH IDLE WITH WARM ENGINE.
5. CLOGGED FUEL FILTER	<p>Disconnect inlet hose to fuel filter, and feed clean fuel directly into pump.</p> <p>HINT: When feeding fuel directly into pump, keep container at same level as vehicle fuel tank.</p> <p>If engine condition improves, fuel filter is clogged and should be replaced.</p> <p>If no increase in engine condition after replacing fuel filter, check priming pump (hand pump) or perform other necessary repairs.</p>
6. IMPROPER INJECTION TIMING	Refer to step 7 of ENGINE CRANKS NORMALLY BUT WILL NOT START.
7. FAULTY INJECTION NOZZLES	Refer to step 9 of ENGINE CRANKS NORMALLY BUT WILL NOT START.

EXCESSIVE EXHAUST SMOKE

HINT:

- Check that the air cleaner is not clogged.
 - Check with the customer whether or not oil consumption has been excessive.
-
-

(Possible Cause)	(Check Procedure and Correction Method)
1. IMPROPER INJECTION TIMING	<p>Refer to step 7 of ENGINE CRANKS NORMALLY BUT WILL NOT START.</p> <p>HINT: Black smoke indicates advanced timing while white smoke indicates retarded timing. Adjustments should be made accordingly.</p>
2. CLOGGED FUEL FILTER	<p>Refer to step 5 of LACK OF POWER.</p> <p>HINT: At high speed (2,000 – 3,000 rpm), a clogged filter tends to make exhaust smoke white.</p>
3. FAULTY INJECTION NOZZLES	<p>Refer to step 9 of ENGINE CRANKS NORMALLY BUT WILL NOT START.</p> <p>HINT: Excessive exhaust smoke is often caused by nozzle pressure being too low.</p>

EXCESSIVE FUEL CONSUMPTION

HINT: Check whether clutch slipping, brakes grabbing, tires wrong size or air filter clogged.

(Possible Cause)	(Check Procedure and Correction Method)
1. FUEL LEAKAGE	Refer to step 3 of ROUGH IDLE WITH WARM ENGINE.
2. IDLE SPEED TOO HIGH	After sufficiently warming up engine, check idle speed. (See page EM-27) Idle speed: 2L-T 700 – 800 rpm 3L 650 – 750 rpm If not as above, adjust with idle speed adjusting screw.
3. MAXIMUM SPEED TOO HIGH	Check maximum speed. (See page EM-27) Maximum speed: 2L-T 4,700 – 4,900 rpm 3L (Hong Kong, Singapore and Malaysia) 4,300 – 4,500 rpm 3L (Others) 4,500 – 4,700 rpm If not as above, adjust with maximum speed adjusting screw.
4. IMPROPER INJECTION TIMING	Refer to step 7 of ENGINE CRANKS NORMALLY BUT WILL NOT START.
5. FAULTY INJECTION NOZZLES	Refer to step 9 of ENGINE CRANKS NORMALLY BUT WILL NOT START.

ENGINE NOISE WHEN WARM (Cranking Noise with Excessive Vibration)

(Possible Cause)

(Check Procedure and Correction Method)

1. ENGINE COOLANT TEMPERATURE TOO LOW

Check coolant temperature with water temperature gauge.
If not sufficiently warm, thermostat is faulty and should be replaced.

2. IMPROPER INJECTION TIMING

Refer to step 7 of ENGINE CRANKS NORMALLY BUT WILL NOT START.

3. FAULTY INJECTION NOZZLES

Refer to step 9 of ENGINE CRANKS NORMALLY BUT WILL NOT START.

ENGINE WILL NOT RETURN TO IDLE

(Possible Cause)

(Check Procedure and Correction Method)

BINDING ACCELERATOR CABLE

Operate adjusting lever on top of injection pump, and check if engine returns to idle. (See page EM-27)
If so, accelerator cable is binding or improperly adjusted and should be repaired accordingly.
If engine does not return to idle, injection pump is faulty and should be replaced.

ENGINE WILL NOT SHUT OFF WITH KEY

(Possible Cause)

(Check Procedure and Correction Method)

IMPROPER FUEL CUT SOLENOID OPERATION

Disconnect connector of fuel cut solenoid, and check if engine stops.
If so, starter switch is faulty and should be repaired as necessary or replaced.
If engine does not stop, either fuel cut solenoid is faulty or there is interference by foreign particles. Repair as necessary.

Diesel Electrical System Diagnosis [2L-T Austria]

ENGINE DOES NOT START COLD

HINT:

- Battery voltage at least 12 V – starter switch OFF.
- Engine cranks normally.
- Fusible link okay.
- Check the voltage marked with an asterisk (*) just as the starter switch is placed at ON because the voltage will change.

1. Pre-Heating System (Super Glow Type)

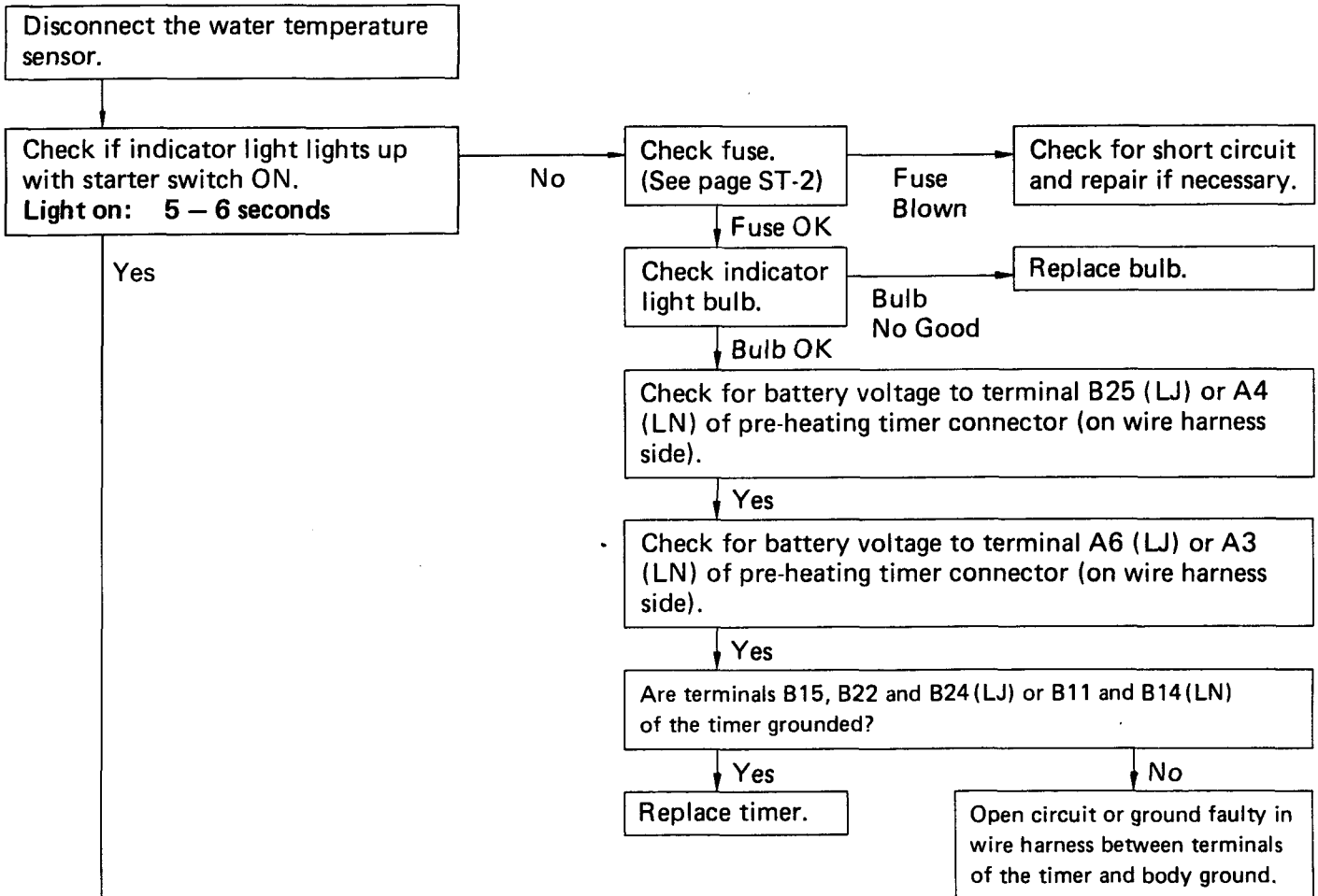

Pre-Heating Timer (Emission Control ECU)

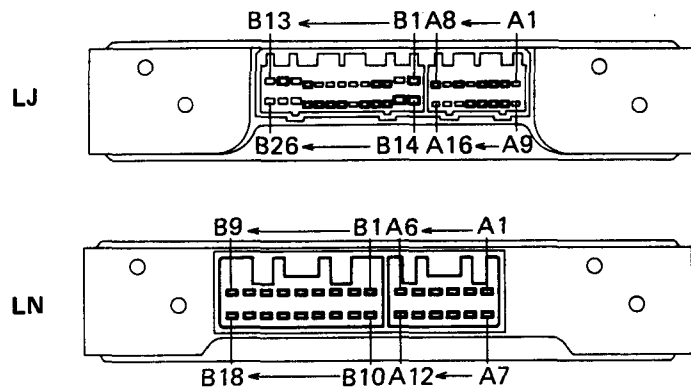

CONTINUED ON PAGE EM-14

CONTINUED FROM PAGE EM-13

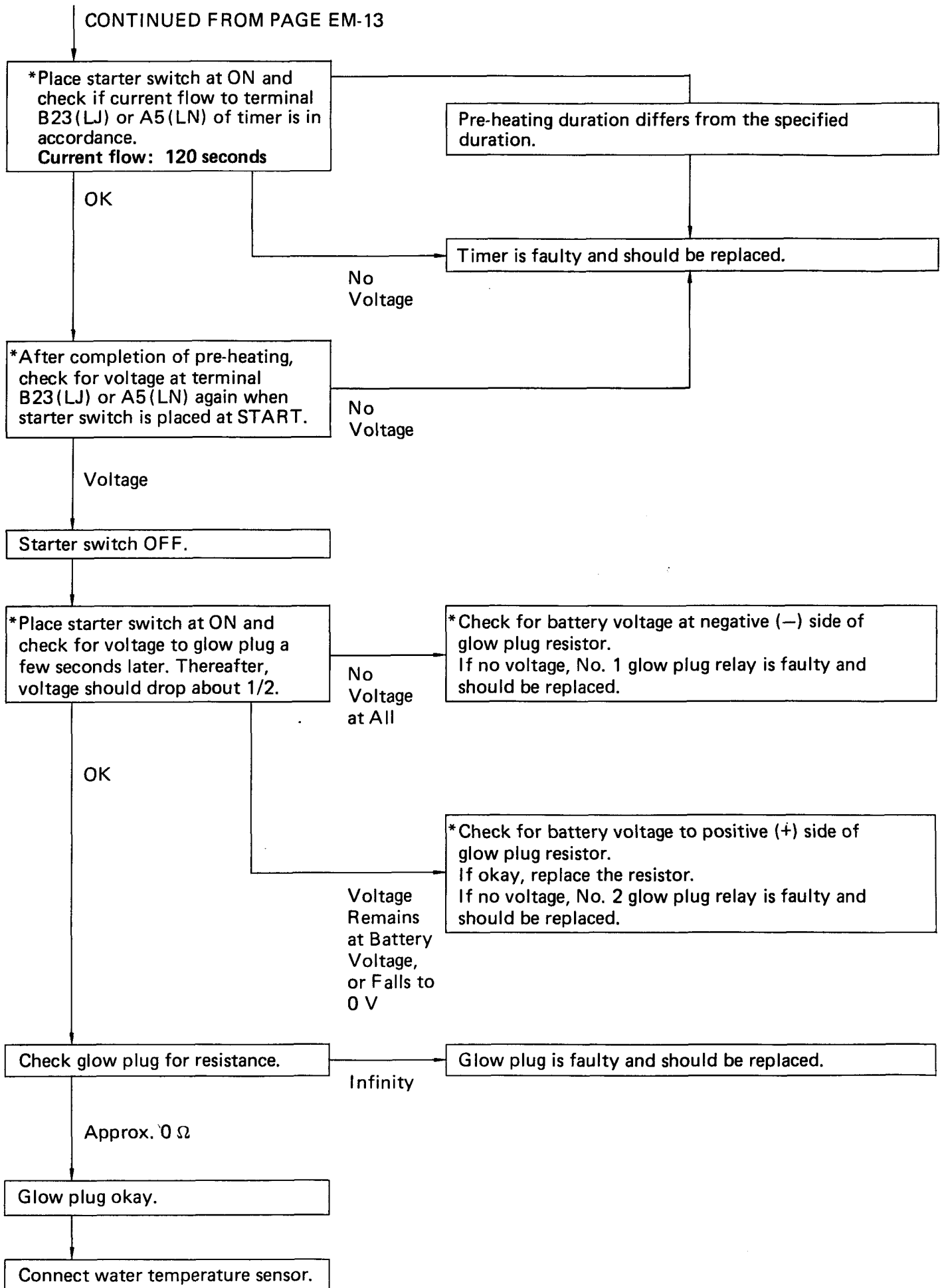

2. Fuel Cut Solenoid Valve

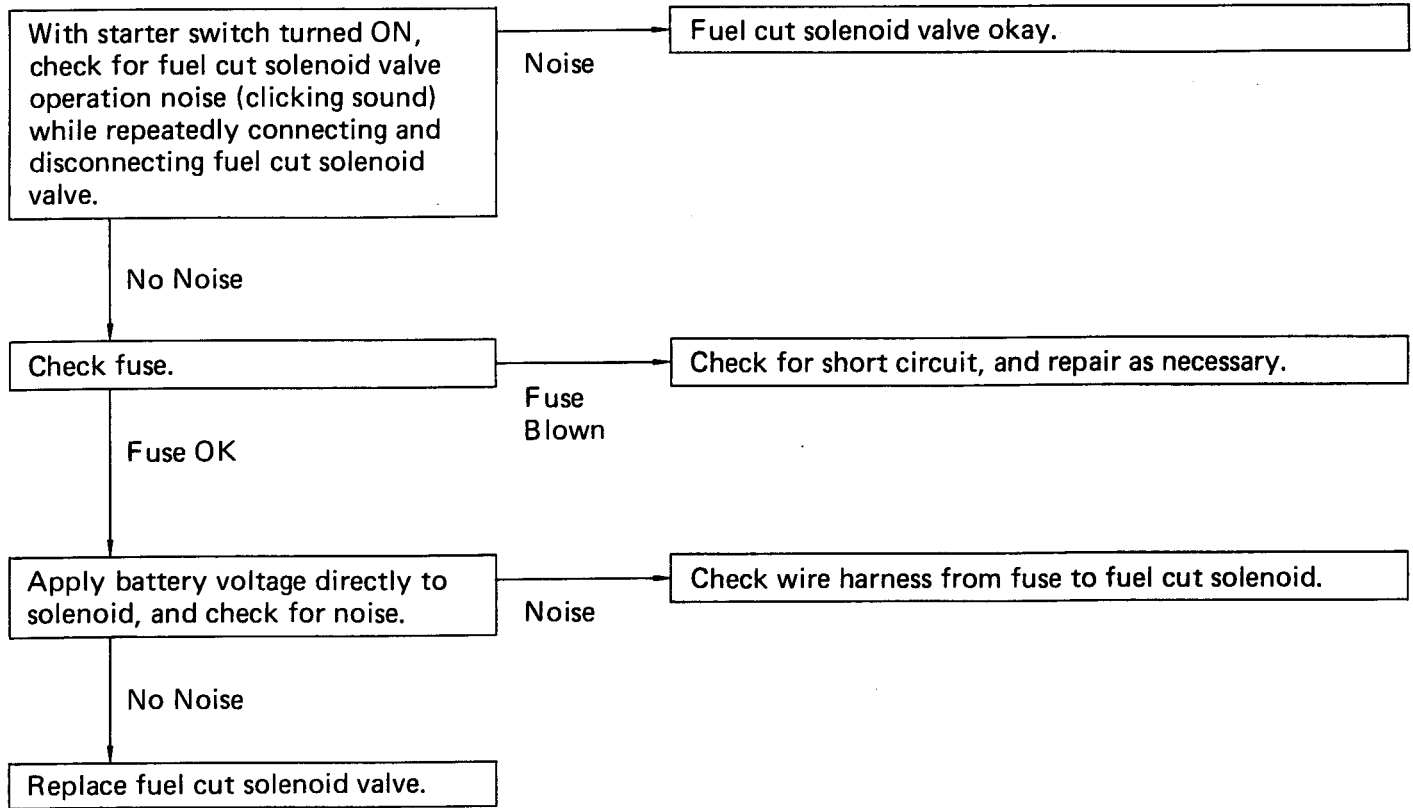

Diesel Electrical System Diagnosis [2L-T Others]

ENGINE DOES NOT START COLD

HINT:

- Battery voltage at least 12 V – starter switch OFF.
- Engine cranks normally.
- Fusible link okay.
- Check the voltage marked with an asterisk (*) just as the starter switch is placed at ON because the voltage will change.

1. Pre-Heating System (Super Glow Type)

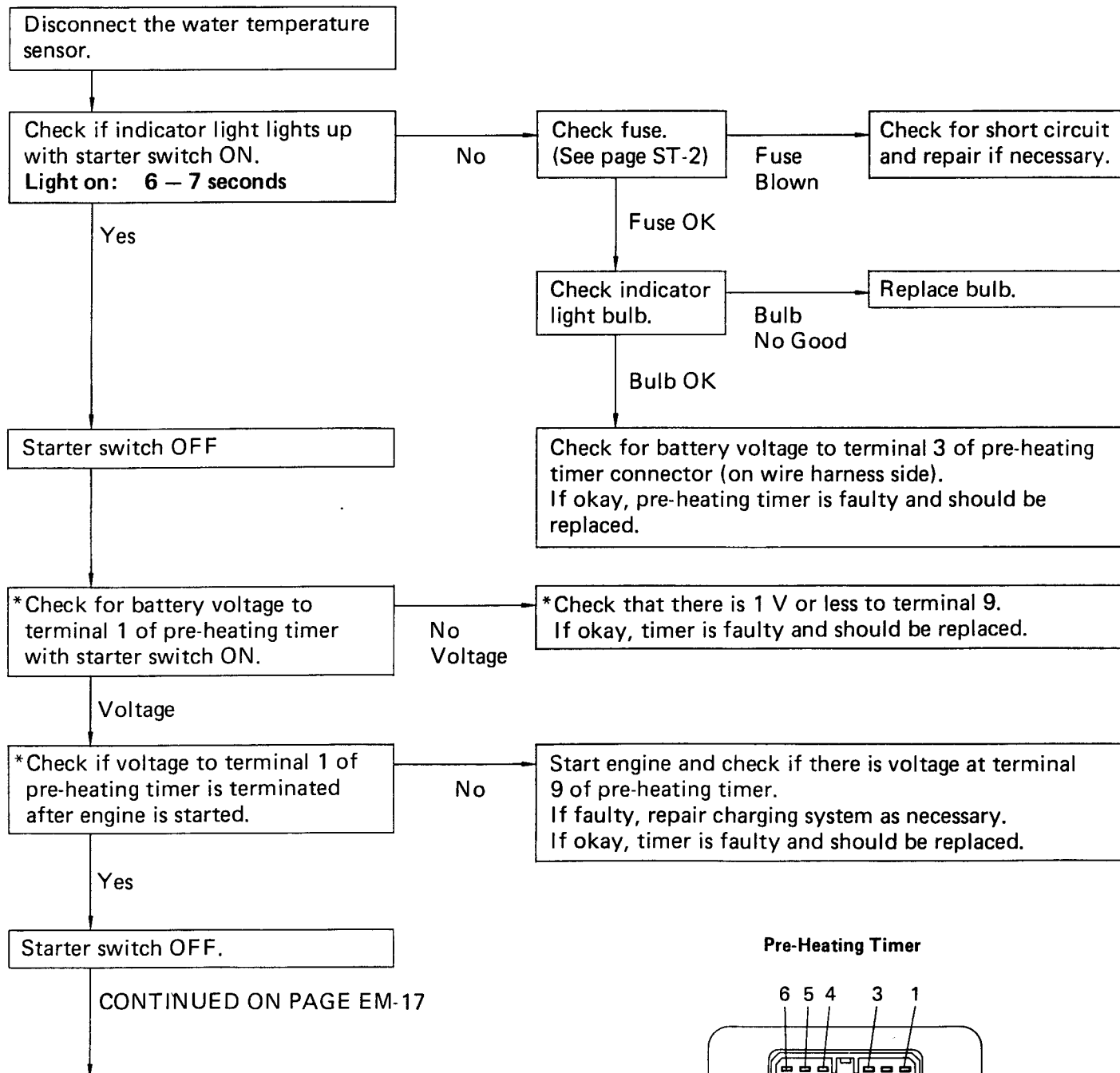

Pre-Heating Timer

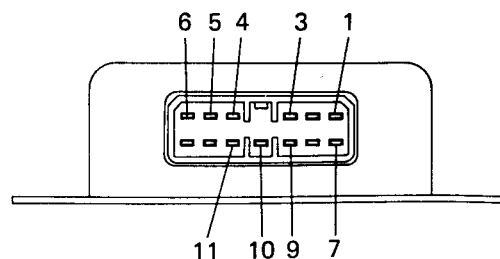

CONTINUED FROM PAGE EM-16

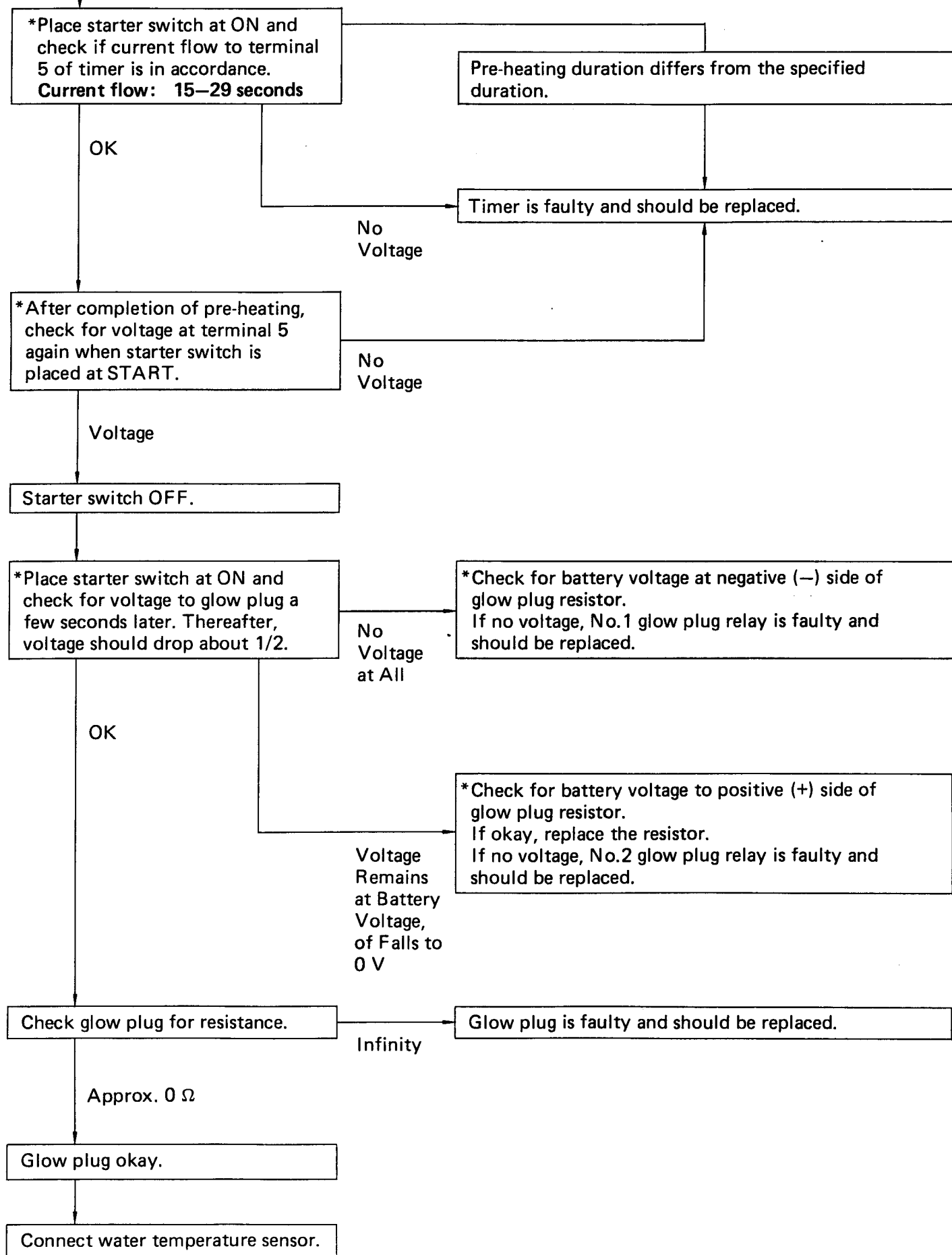

ENGINE TUNE-UP

INSPECTION OF ENGINE COOLANT

(See steps 1 and 2 on page CO-4)

INSPECTION OF ENGINE OIL

(See steps 1 and 2 on page LU-4)

INSPECTION OF BATTERY

(See pages 1 and 2 on page CH-3)

Standard specific gravity:

When fully charged at 20°C (68° F)

1.27 – 1.29 (80D26R)

1.25 – 1.27 (Others)

INSPECTION OF AIR FILTER (Paper Filter Type)

1. INSPECT AIR FILTER

Visually check that the filter element is not excessively dirty, damaged or oily.

2. CLEAN AIR FILTER

Clean the filter element with compressed air.

First blow from the inside thoroughly. Then blow off the outside of the filter element.

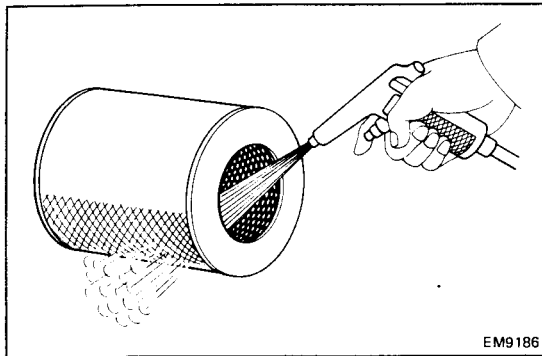

(Washable Type)

1. INSPECT AIR FILTER

Visually check that the filter element is not excessively dirty, damaged or oily.

2. CLEAN AIR FILTER

(a) Blow dirt off in the filter element with compressed air.

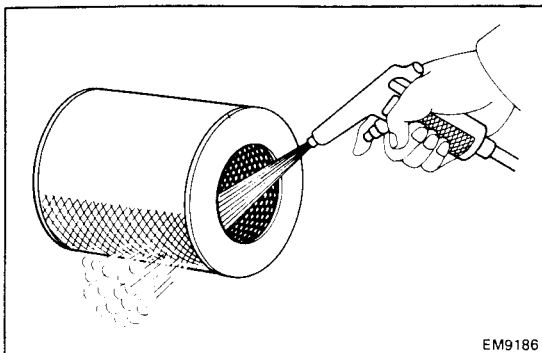

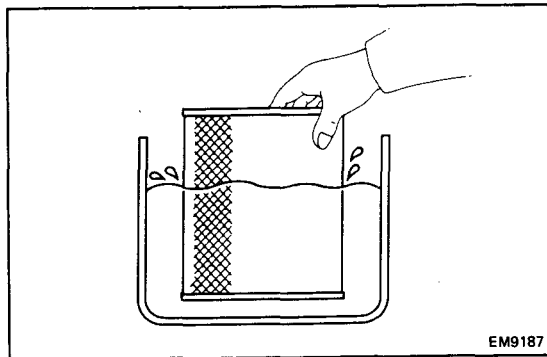

EM9187

- (b) Submerge the filter element in the water and agitate it up and down more than ten times.
- (c) Repeat rinsing in clean water until rinse water is clear.

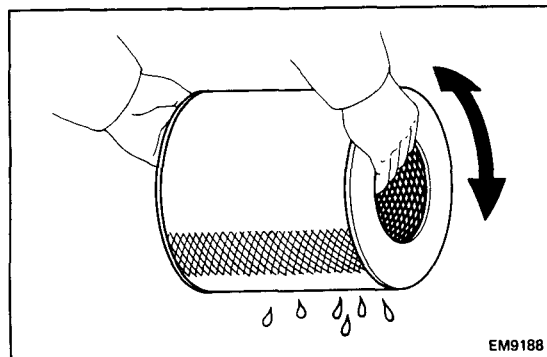

EM9188

- (d) Remove excess water by shaking the filter element or blowing with compressed air.

NOTICE: Do not beat or drop filter element.

- (e) Wipe off dust on the air cleaner case interior.

INSPECTION OF ALTERNATOR DRIVE BELTS

(See step 3 on page CH-3)

Drive belt deflection:

New belt 7 – 10 mm (0.28 – 0.39 in.)

Used belt 10 – 15 mm (0.39 – 0.59 in.)

Drive belt tension (Reference):

New belt 40 – 60 kg

Used belt 20 – 35 kg

INSPECTION OF GLOW PLUGS

(See page ST-6)

ADJUSTMENT OF VALVE CLEARANCE

HINT: Adjust the valve clearance while the engine is cold.

1. (2L-T)
REMOVE AIR CLEANER
2. (w/ Intake Pipe)
REMOVE INTAKE PIPE
3. REMOVE CYLINDER HEAD COVER
(See step 16 on page EM-38)
4. SET NO. 1 CYLINDER TO TDC/COMPRESSION

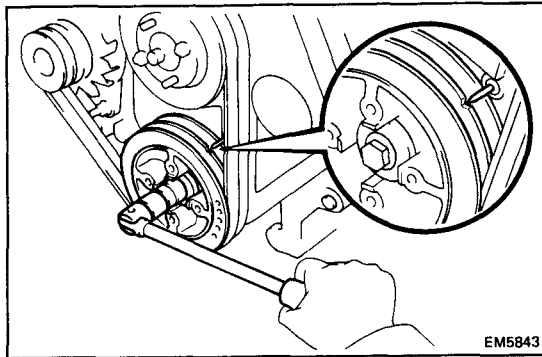

EM5843

- (a) Turn the crankshaft pulley clockwise, and align its groove with the timing pointer.
 - (b) Check that the valve lifters on the No. 1 cylinder are loose and valve lifters on the No. 4 cylinder are tight.
- If not, turn the crankshaft one revolution (360°) and align the mark as above.

5. ADJUST VALVE CLEARANCE

- (a) Check only the valves indicated in the illustration.
 - Using a feeler gauge, measure the clearance between the valve lifter and camshaft.
 - Record the valve clearance measurements which are out of specification. They will be used later to determine the required replacement adjusting shim.

Valve clearance (Cold):

Intake 0.20 – 0.30 mm (0.008 – 0.012 in.)
Exhaust 0.40 – 0.50 mm (0.016 – 0.020 in.)

- (b) Turn the crankshaft one revolution (360°), and align the mark as above (See procedure step 4).
- (c) Check only the valves indicated in the illustration. Measure the valve clearance. (See procedure step (a))
- (d) Remove the adjusting shim.
 - Turn the crankshaft to position the cam lobe of the camshaft on the adjusting valve upward.
 - Using SST, press down the valve lifter.

SST 09248-64010

HINT: Before pressing down the valve lifter, position the notch on the exhaust manifold side.

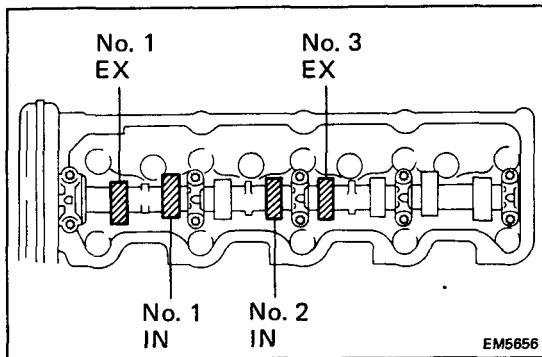

EM5856

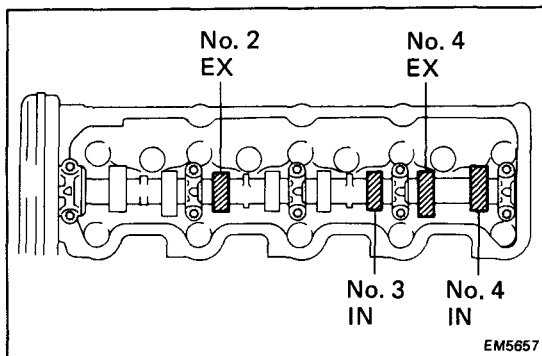

EM5857

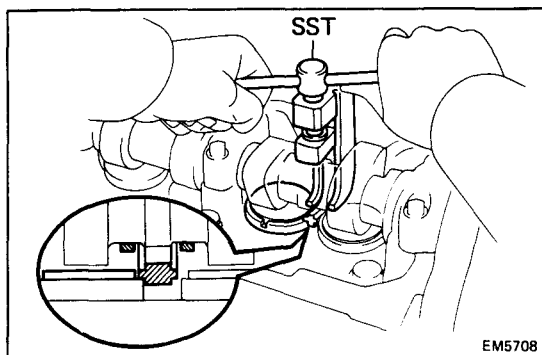

EM5708

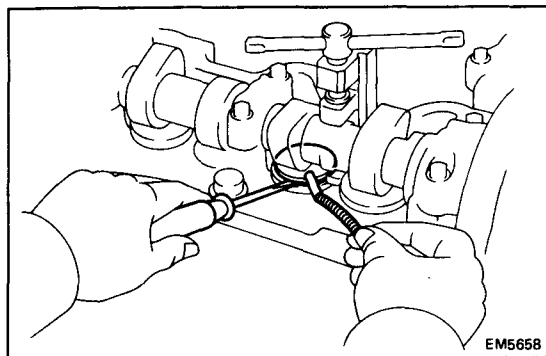

- Remove the adjusting shim with small screwdriver and magnetic finger.

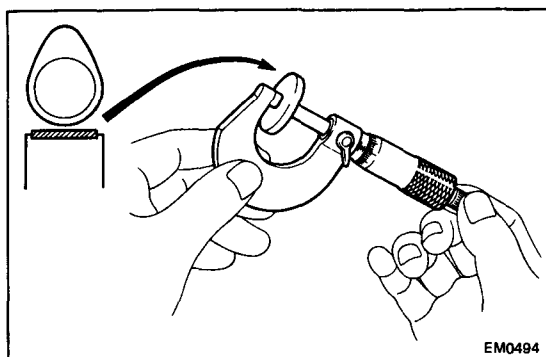

- (e) Determine the replacement adjusting shim size by using following the formula or charts:

- Using a micrometer, measure the thickness of the shim which was removed.
- Calculate the thickness of the new shim so the valve clearance comes within specified value.

T Thickness of used shim

A Measured valve clearance

N Thickness of new shim

Intake side: $N = T + (A - 0.25 \text{ mm (0.010 in.)})$

Exhaust side: $N = T + (A - 0.45 \text{ mm (0.018 in.)})$

- Select a new shim with a thickness as close as possible to the calculated values.

HINT: Shims are available in seventeen sizes in increments of 0.050 mm (0.0020 in.), from 2.500 mm (0.0984 in.) to 3.300 mm (0.1299 in.).

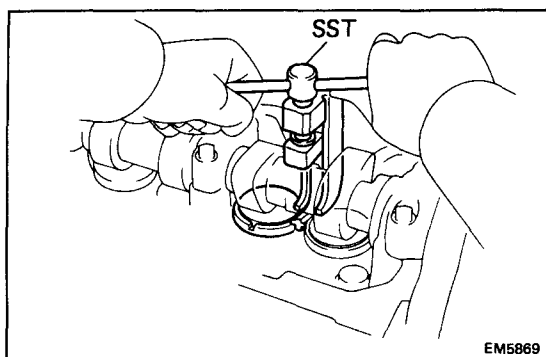

- (f) Install a new adjusting shim.

- Place a new adjusting shim on the valve lifter.
- Remove SST.

SST 09248-64010

- (g) Recheck the valve clearance.

6. REINSTALL CYLINDER HEAD COVER
(See step 4 on page EM-43)

7. (w/ Intake Pipe)
REINSTALL INTAKE PIPE

8. (2L-T)
REINSTALL AIR CLEANER

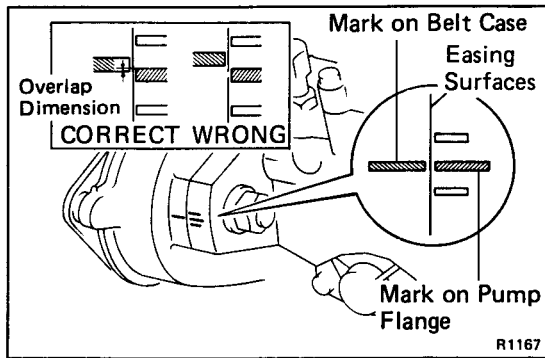

INSPECTION AND ADJUSTMENT OF INJECTION TIMING (2L-T Austria)

1. CHECK INJECTION TIMING

Using a mirror, check that the mark on the belt case and the center mark on the pump flange are correctly aligned with the amount of overlap as shown.

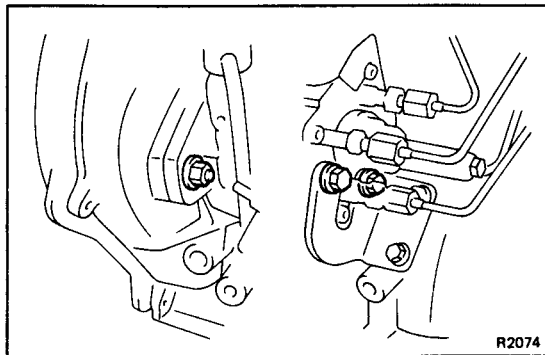

2. ADJUST INJECTION TIMING

(a) Loosen the following bolts and nuts:

- (1) Two bolts holding injection pump to injection pump stay.
- (2) Two nuts holding injection pump to timing belt case.

HINT: Do not loosen the union nuts of injection pump more than 1/4 of a turn.

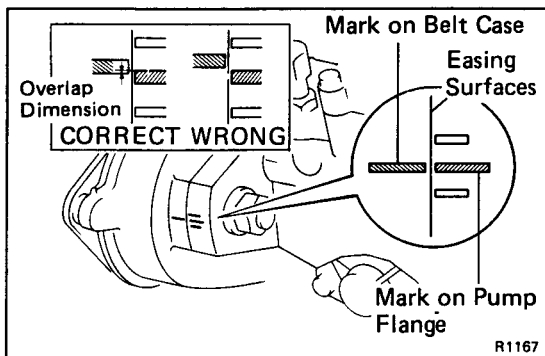

(b) Slightly tilt the injection pump body and align the belt case mark with the center mark on the pump flange to the correct overlap dimension.

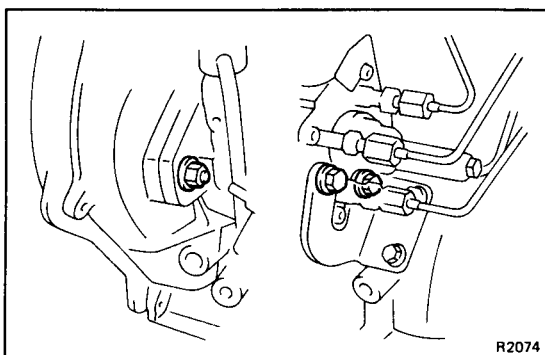

(c) Tighten the following bolts and nuts:

- (1) Two nuts holding injection pump to timing belt case.

Torque: 210 kg-cm (15 ft-lb, 21 N·m)

- (2) Two bolts holding injection pump to injection pump stay.

Torque: 185 kg-cm (13 ft-lb, 18 N·m)

3. START ENGINE AND CHECK FOR LEAKS

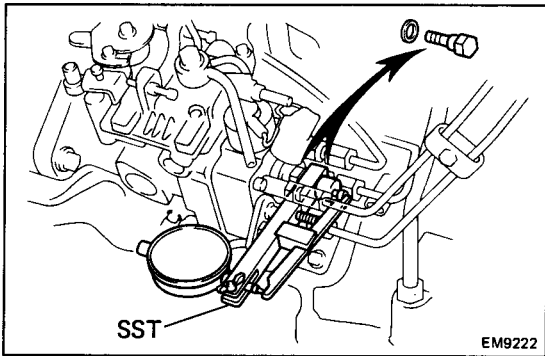

ADJUSTMENT OF INJECTION TIMING (Others)

1. INSTALL SST AND DIAL INDICATOR

- Remove the plug bolt and gasket from the distributive head plug of the injection pump.
- Install SST (plunger stroke measuring tool) and a dial indicator to the plug bolt hole of distributive head plug.

SST 09275-54010

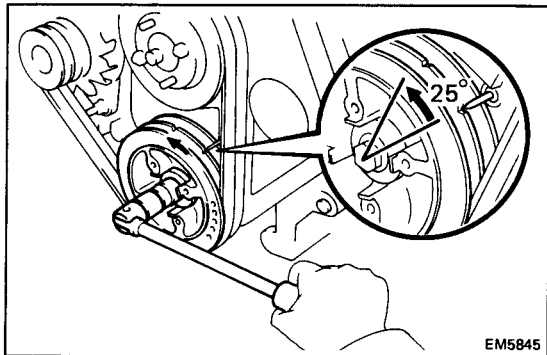

2. SET NO. 1 OR NO. 4 CYLINDER TO 25° OR MORE BTDC/COMPRESSION

Turn the crankshaft pulley clockwise so the pulley groove is 25° or more from the timing pointer.

3. (2L-T) RELEASE ACSD ADVANCE

- Using a screwdriver, turn the cold starting lever counterclockwise approx. 20°.
- Put a metal plate (thickness of 8.5 – 10 mm (0.335 – 0.394 in.)) between the cold starting lever and thermo wax plunger.

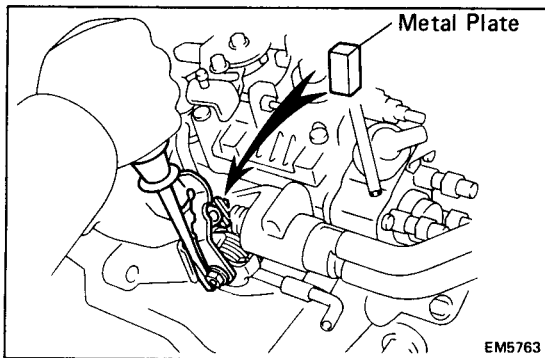

4. ADJUST INJECTION TIMING

- Set the dial indicator at 0 mm (0 in.).
- Recheck to see that the dial indicator remains at 0 mm (0 in.) while slightly rotating the crankshaft pulley clockwise or counterclockwise.

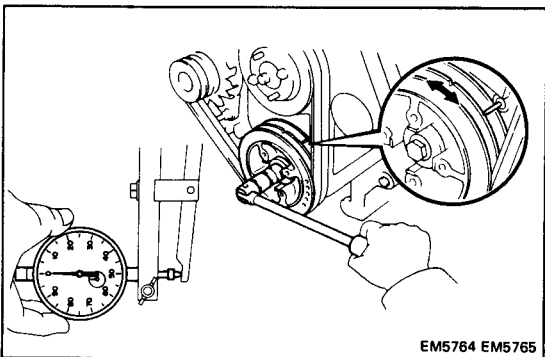

- Slowly rotate the crankshaft pulley clockwise until pulley groove is aligned with the timing pointer.
- Measure the plunger stroke.

Plunger stroke:

2L-T 0.54 – 0.66 mm (0.0213 – 0.0260 in.)

3L 0.84 – 0.96 mm (0.0331 – 0.0378 in.)

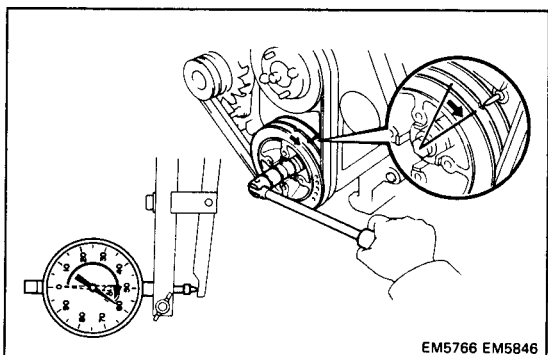

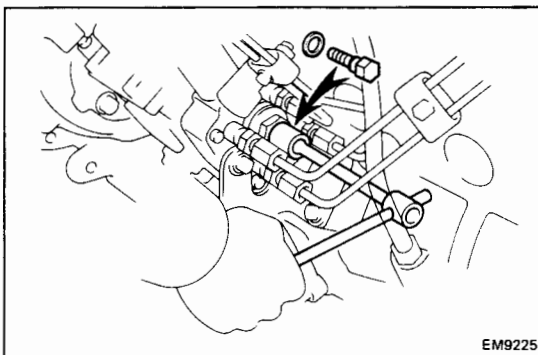
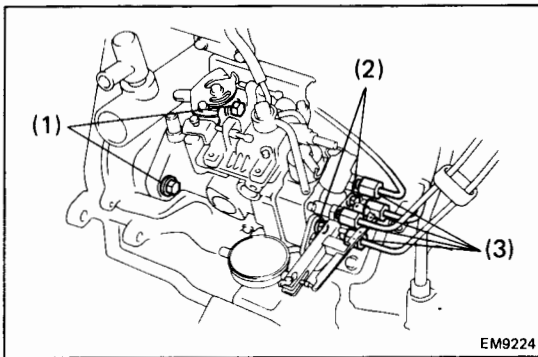
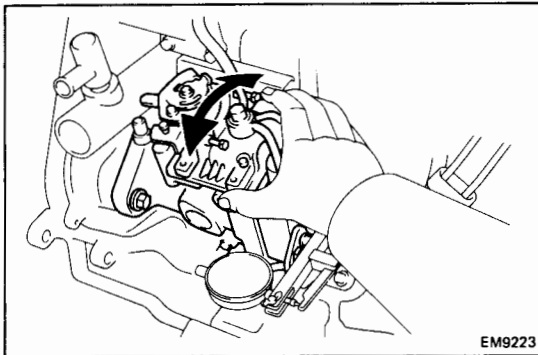
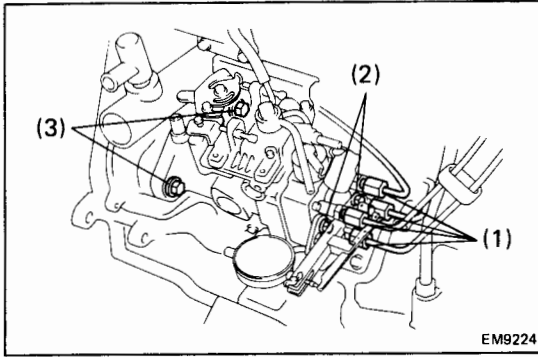

(e) Loosen the following bolts and nuts:

- (1) Four union nuts of injection pipes at injection pump side.
- (2) Two bolts holding injection pump to injection pump stay.
- (3) Two nuts holding injection pump to timing belt case.

HINT: Do not loosen the union nuts of injection pump more than 1/4 of a turn.

(f) Adjust plunger stroke by slightly tilting the injection pump body.

If the stroke is less than specified, tilt the pump toward the engine.

If the stroke is greater than specified, tilt the pump away from the engine.

(g) Tighten the following bolts and nuts:

- (1) Two nuts holding injection pump to timing belt case.

Torque: 210 kg-cm (15 ft-lb, 21 N-m)

- Recheck the plunger stroke.

- (2) Two bolts holding injection pump to injection pump stay.

Torque: 185 kg-cm (13 ft-lb, 18 N-m)

- (3) Four union nuts of injection pipes.

Torque: 250 kg-cm (18 ft-lb, 25 N-m)

5. (2L-T)
REMOVE METAL PLATE

6. **REMOVE SST AND DIAL INDICATOR**

- (a) Remove SST and the dial indicator.

SST 09275-54010

- (b) Install a new gasket and the plug bolt of the distributive head plug.

Torque: 170 kg-cm (12 ft-lb, 17 N-m)

7. **START ENGINE AND CHECK FOR LEAKS**

ADJUSTMENT OF IDLE SPEED AND MAXIMUM SPEED

1. INITIAL CONDITIONS

- (a) Engine at normal operating temperature
- (b) Air cleaner installed
- (c) All accessories switched OFF
- (d) All vacuum lines properly connected
- (e) Valve clearance set correctly
- (f) Injection timing set correctly
- (g) Transmission in neutral range

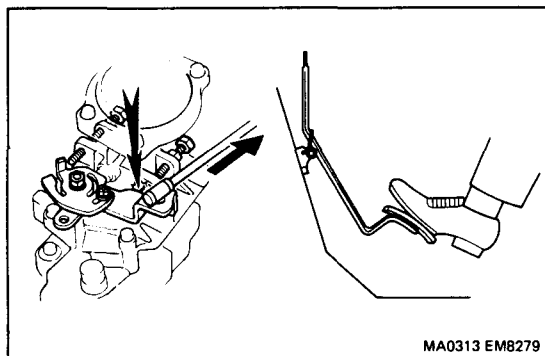

2. CONNECT TACHOMETER

3. ADJUST IDLE SPEED

- (a) Check that the adjusting lever touches the idle speed adjusting screw when the accelerator pedal is released.

If not, adjust the accelerator linkage.

- (b) Start the engine.

- (c) Check the idle speed.

Idle speed: 2L-T 700 – 800 rpm
3L 650 – 750 rpm

- (d) Adjust the idle speed.

- Disconnect the accelerator linkage.
- Loosen the lock nut of the idle speed adjusting screw.
- Adjust the idle speed by turning the IDLE SPEED ADJUSTING SCREW.

Idle speed: 2L-T 750 rpm
3L 700 rpm

- Securely tighten the lock nut, and recheck the idle speed.
- Reconnect the accelerator linkage.
- After adjustment, adjust the accelerator linkage.

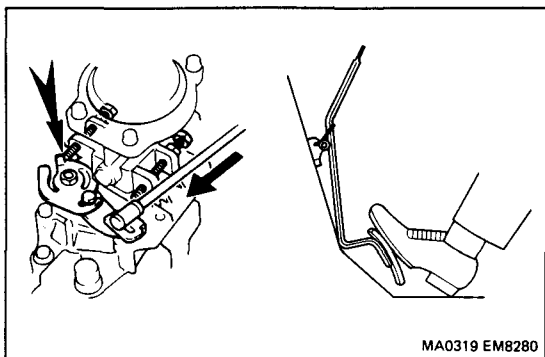
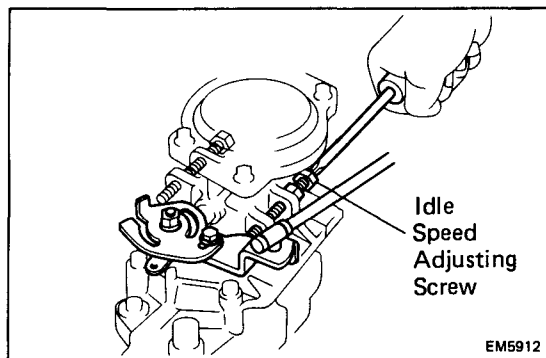

4. ADJUST MAXIMUM SPEED

- (a) Check that the adjusting lever touches the maximum speed adjusting screw when the accelerator pedal is depressed all the way.

If not, adjust the accelerator linkage.

- (b) Start the engine.

- (c) Depress the accelerator pedal all the way.

(d) Check the maximum speed.

Maximum speed:

- 2L-T 4,700 – 4,900 rpm
- 3L (Hong Kong, Singapore and Malaysia)
 4,300 – 4,500 rpm
- 3L (Others) 4,500 – 4,700 rpm

(e) Adjust the maximum speed.

- Disconnect the accelerator linkage.
- Cut out the seal wire of the maximum speed adjusting screw.
- (2L-T and w/ HAC)
Using SST, loosen the lock nut of the maximum speed adjusting screw.

SST 09275-54020

- (w/o HAC)
Loosen the lock nut of the maximum speed adjusting screw.

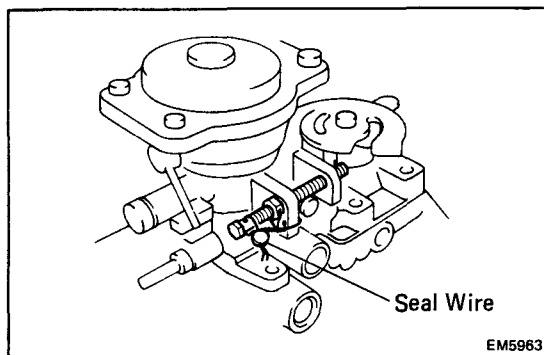
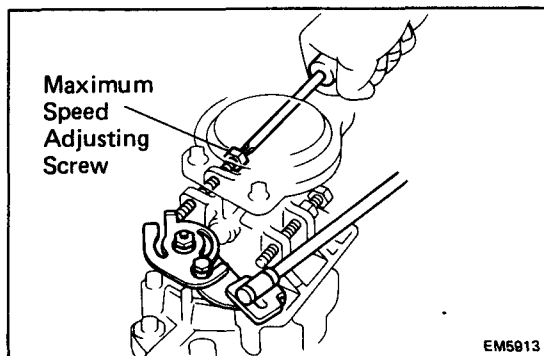
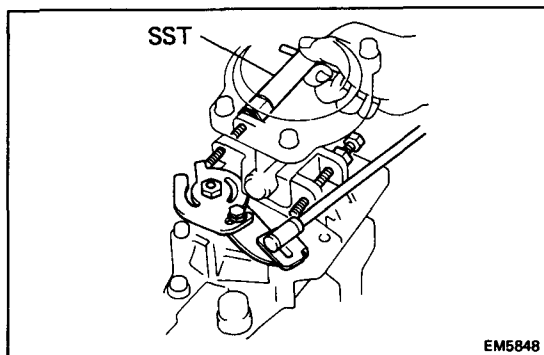

- Adjust the maximum speed by turning the **MAXIMUM SPEED ADJUSTING SCREW**.

Maximum speed:

- 2L-T 4,800 rpm
- 3L (Hong Kong, Singapore and Malaysia)
 4,400 rpm
- 3L (Others) 4,600 rpm

HINT: Adjust at idle speed. Then, raise engine speed and recheck the maximum speed.

- (2L-T and w/ HAC)
Using SST, securely tighten the lock nut.

SST 09275-54020

- (w/o HAC)
Securely tighten the lock nut.
- Recheck the maximum speed.
- Reconnect the accelerator linkage.
- After adjustment, adjust the accelerator linkage.
- Seal the maximum speed adjusting screw with a new seal wire.

ADJUSTMENT OF AIR CONDITIONER IDLE-UP SETTING SPEED

1. INITIAL CONDITIONS

- (a) Engine at normal operating temperature
- (b) Air cleaner installed
- (c) All vacuum lines properly connected
- (d) Valve clearance set correctly
- (e) Injection timing set correctly
- (f) Transmission in neutral range
- (g) Idle speed set correctly

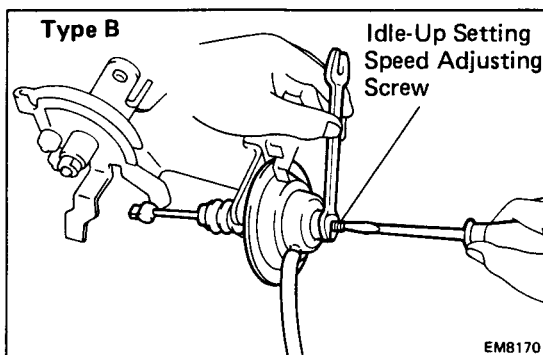
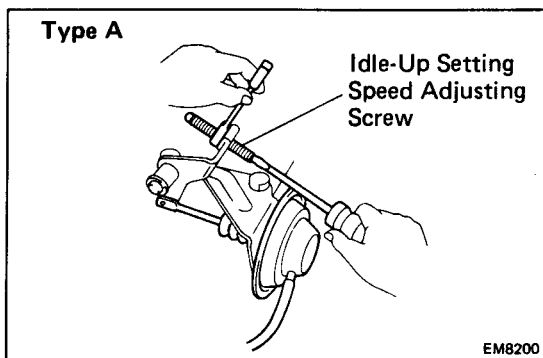
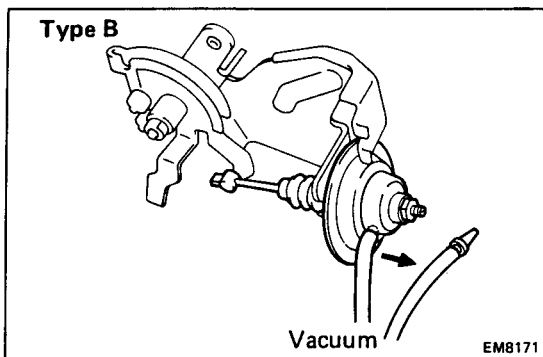
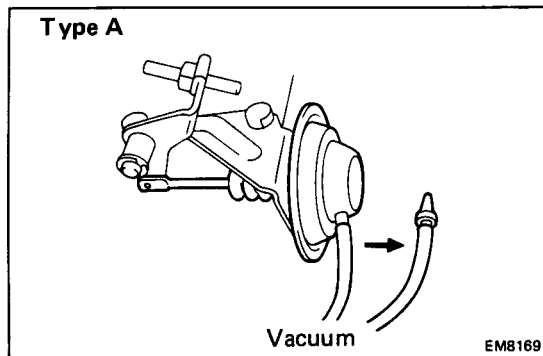

2. CONNECT TACHOMETER

3. ADJUST AIR CONDITIONER IDLE-UP SETTING SPEED

- (a) Start the engine.
- (b) A/C switches ON.
- (c) Disconnect the vacuum hose from the idle-up actuator.
- (d) Apply vacuum to the idle-up actuator.
- (e) Race the engine to 2,500 rpm for a few seconds, release the throttle and check the idle-up setting speed.

A/C idle-up setting speed: 950 rpm

- (f) Adjust the idle-up setting speed by turning the IDLE-UP SETTING SPEED ADJUSTING SCREW.
- (g) Race the engine to 2,500 rpm for a few seconds, release the throttle and recheck the A/C idle-up setting speed.
- (h) Reconnect the vacuum hose to the idle-up actuator.

INTAKE VENTURI SYSTEM (LN 2L-T only)

ON-VEHICLE INSPECTION

NOTICE: Always stop the engine when installing or removing the vacuum gauges, or removing the vacuum hoses.

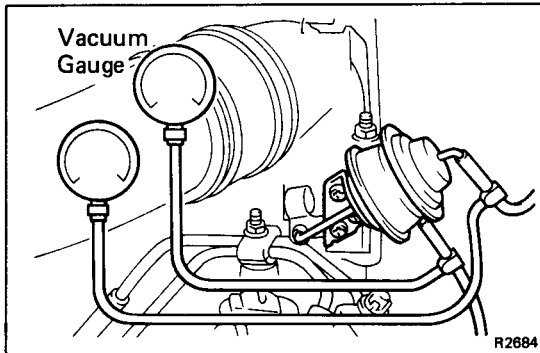

(Austria)

1. PREPARATION

Using two 3-way connectors, connect two vacuum gauges to hoses between the actuator and VSV.

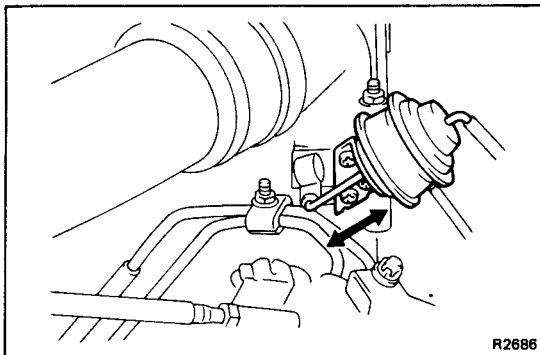

2. CHECK THROTTLE VALVE (LOW ALTITUDE AREA)

HINT: Perform this check at an altitude below 800 m (2,600 ft) and at an atmospheric pressure above 700 mm Hg (94.5 kg/cm²).

- (a) Start the engine and check that vacuum operates on diaphragm chamber B so that the rods are pulled up.
- (b) Check that when the accelerator pedal is depressed, atmospheric air operates on both diaphragm chambers so that the rods return.

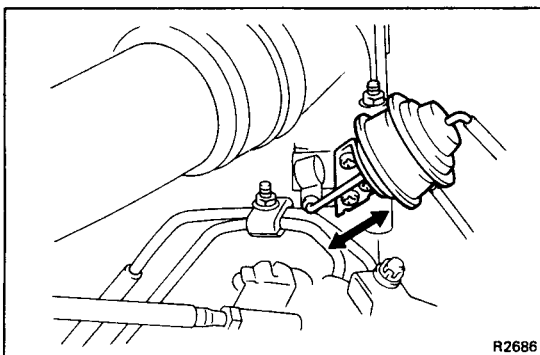

- (c) Check that when the starter switch is turned OFF (engine stopped) from idling condition, vacuum operates on both diaphragm chambers so that the rods are pulled up.

- (d) Check that after the starter switch is turned OFF, the rods gradually return.

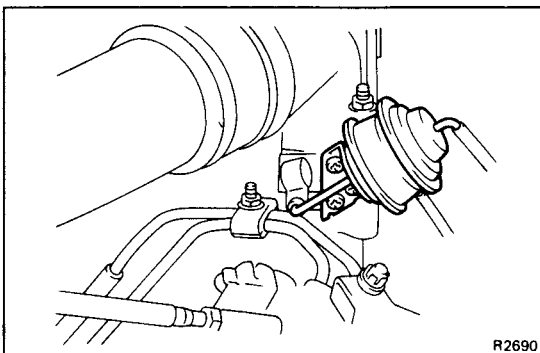

3. CHECK THROTTLE VALVE (HIGH ALTITUDE AREA)

HINT: Perform this check at an altitude above 800 m (2,600 ft) and at an atmospheric pressure below 690 mm Hg (93.2 kg/cm²).

Check that during idling or with the starter switch OFF (engine stopped), vacuum is not operating on either diaphragm chamber.

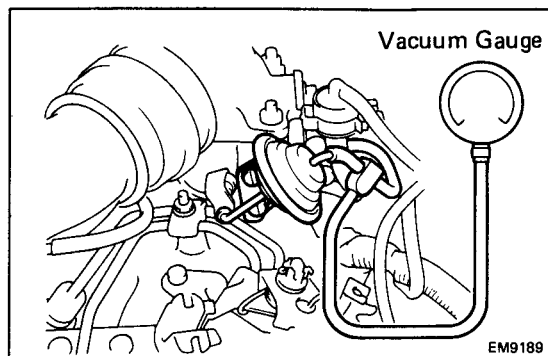
**(Others)****1. PREPARATION**

Using a 3-way connector, connect a vacuum gauge to hose between the actuator and VSV.

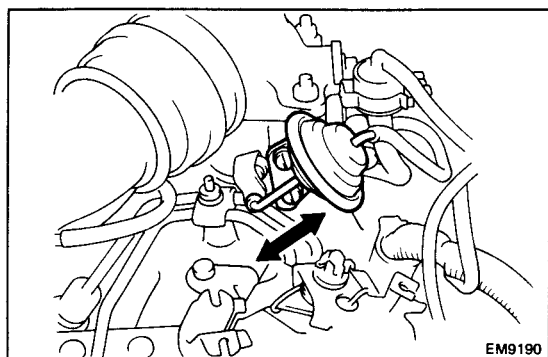
**2. CHECK THROTTLE VALVE**

- (a) Start the engine and check that the vacuum gauge indicates zero vacuum.
- (b) Check that when the starter switch is turned OFF (engine stopped) from idling condition, vacuum operates on the diaphragm chamber so that the rods return.
- (c) Check that after the starter switch is turned OFF, the rods gradually return.

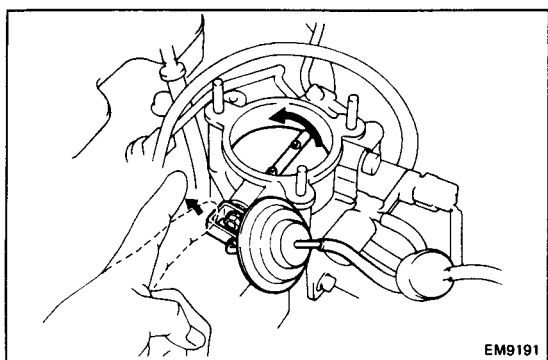
**INSPECTION OF INTAKE VENTURI SYSTEM COMPONENTS****1. INSPECT VENTURI**

- (a) Fully close the throttle valve, and check that it returns smoothly.

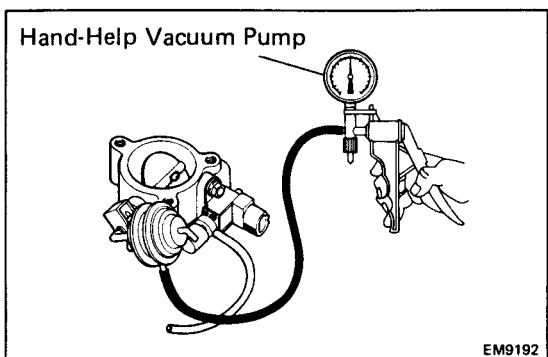

- (b) (Austria)
Using the hand-help vacuum pump, check that when vacuum is gradually applied to diaphragm chamber B of the actuator, the throttle valve opens half-way.

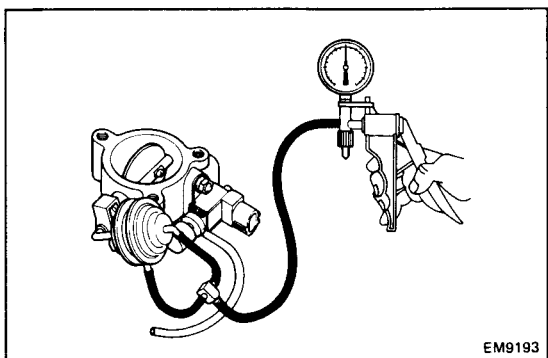

- (c) (Austria)
Using the hand-help vacuum pump check that when vacuum is gradually applied to diaphragm chambers A and B of the actuator, the throttle valve fully opens.

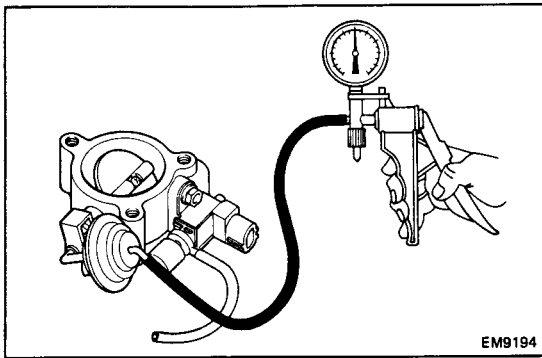

(d) (Others)

Using the hand-help vacuum pump, check that when vacuum is gradually applied to the diaphragm chamber of the actuator, the throttle valve opens half-way.

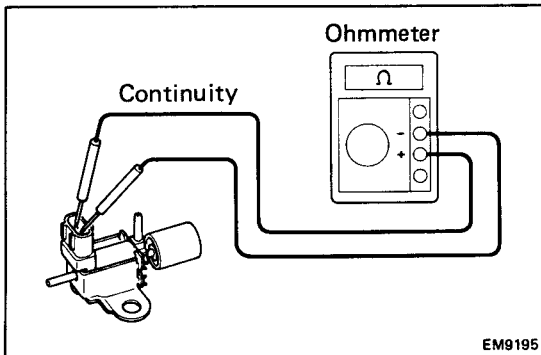

2. INSPECT VSV

A. Inspect VSV for open circuit

Using an ohmmeter, check that there is continuity between the terminals.

Resistance (Cold): 37 – 44 Ω

If there is no continuity, replace the VSV.

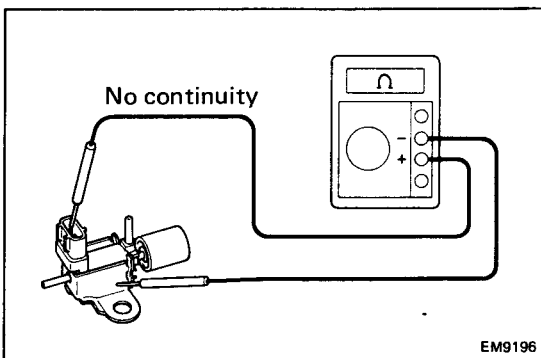

B. Inspect VSV for ground

Using an ohmmeter, check that there is no continuity between each terminal and the body.

If there is continuity, replace the VSV.

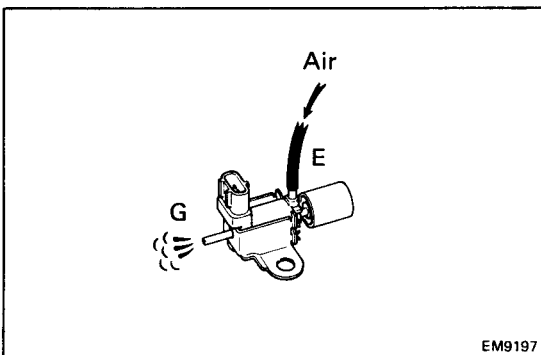

C. Inspect VSV operation

(a) Check that air flows from pipes E to G.

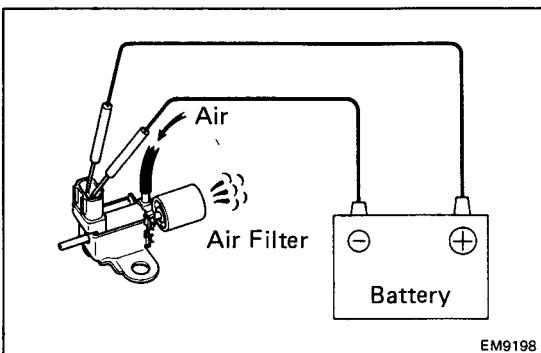

(b) Apply battery voltage across the terminals.

(c) Check that air flows from port E to the filter.

If operation is not as specified, replace the VSV.

COMPRESSION CHECK

HINT: If there is lack of power, excessive oil consumption or poor fuel economy, measure the compression pressure.

1. WARM UP AND STOP ENGINE

Allow the engine to reach normal operating temperature.

2. DISCONNECT INJECTION PUMP (FUEL CUT SOLENOID) CONNECTOR

3. REMOVE AIR CLEANER

4. (w/ Intake Pipe) REMOVE INTAKE PIPE

5. REMOVE GLOW PLUGS

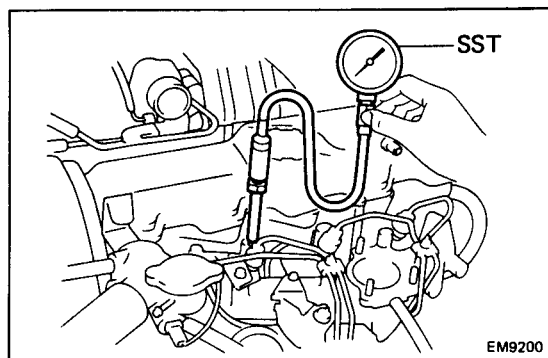
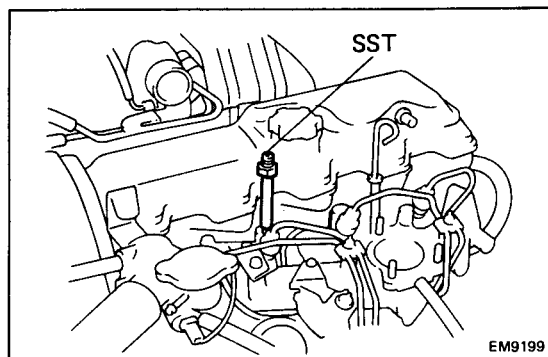

6. CHECK CYLINDER COMPRESSION PRESSURE

(a) Install SST (attachment) to the glow plug hole.

SST 09992-00024 (09992-00121)

(b) Connect SST (compression gauge) to SST (attachment).

SST 09992-00024 (09992-00121, 09992-00211)

(c) Fully open the throttle valve.

(d) While cranking the engine, measure the compression pressure.

HINT: Always use a fully charged battery to obtain engine revolution of 250 rpm or more.

(e) Repeat steps (a) through (d) for each cylinder.

NOTICE: This measurement must be done in as short a time as possible.

Compression pressure:

2L-T 31.0 kg/cm² (441 psi, 3,040 kPa) or more

3L 32.0 kg/cm² (455 psi, 3,138 kPa) or more

Minimum pressure:

20.0 kg/cm² (284 psi, 1,961 kPa)

Difference between each cylinder:

5.0 kg/cm² (71 psi, 490 kPa) or less

- (f) If the cylinder compression in one or more cylinders is low, pour a small amount of engine oil into the cylinder through the glow plug hole and repeat steps (a) through (d) for the cylinder with low compression.
- If adding oil helps the compression, chances are that the piston rings and/or cylinder bore are worn or damaged.
 - If pressure stays low, a valve may be sticking or seating improperly, or there may be leakage past the gasket.

7. REINSTALL GLOW PLUGS
8. (w/ Intake Pipe)
REINSTALL INTAKE PIPE
9. REINSTALL AIR CLEANER
10. RECONNECT INJECTION PUMP (FUEL CUT SOLENOID) CONNECTOR

CYLINDER HEAD (2L-T)

COMPONENTS

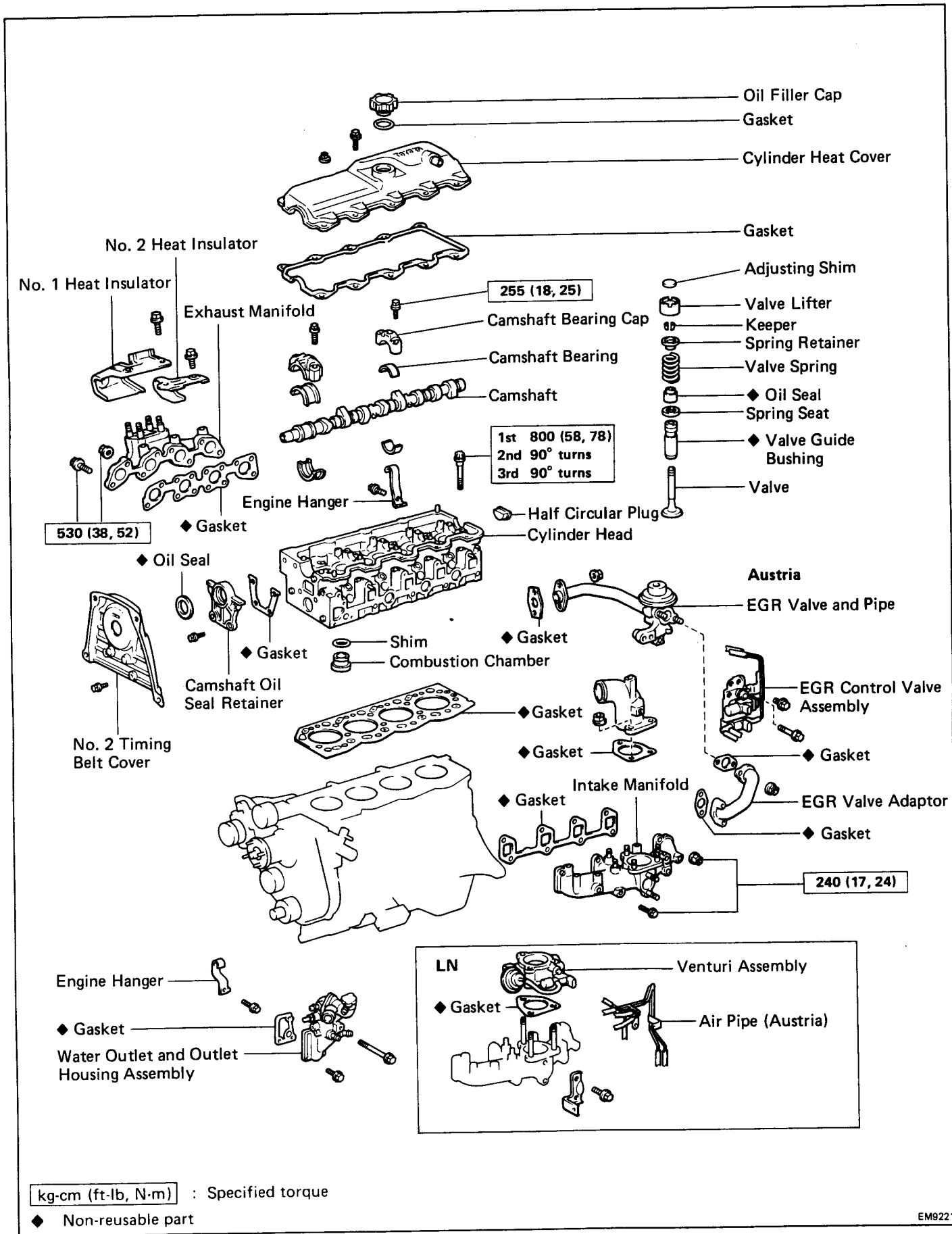

kg-cm (ft-lb, N-m) : Specified torque

◆ Non-reusable part

REMOVAL OF CYLINDER HEAD

(See page EM-35)

1. DRAIN ENGINE COOLANT (See page CO-4)
2. REMOVE TURBOCHARGER
(See steps 2 to 7 on pages TC-10 and 11)
3. REMOVE TIMING BELT
(See steps 2 to 7 on page FU-4)
4. REMOVE INJECTION PUMP
(See steps 8 to 16 on pages FU-4 and 5)
5. REMOVE INJECTION NOZZLES
6. REMOVE CAMSHAFT TIMING PULLEY

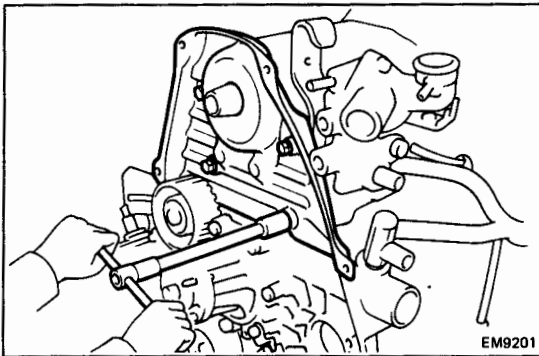
**7. REMOVE NO. 2 TIMING BELT COVER**

Remove the four bolts and belt cover.

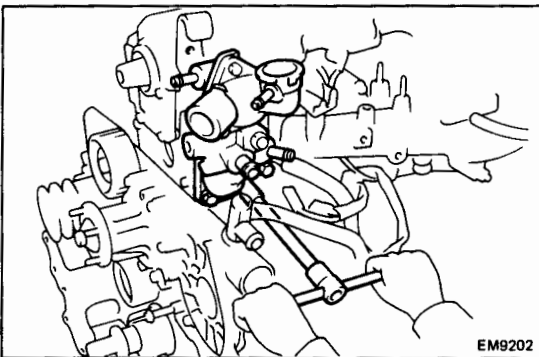
**8. REMOVE WATER OUTLET AND OUTLET HOUSING ASSEMBLY**

- (a) Disconnect the water temperature switch connector.
- (b) Disconnect the by-pass hose from the thermo wax of the injection pump.
- (c) Remove the three bolts, water outlet, outlet housing assembly and gasket.

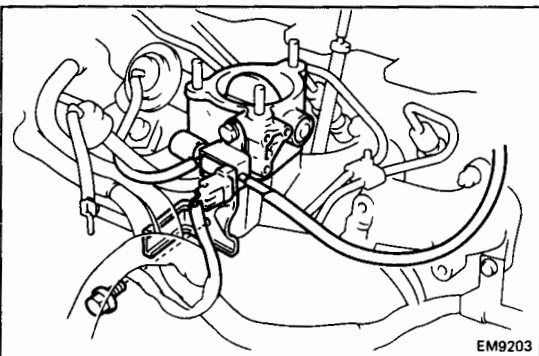
9. REMOVE LH ENGINE HANGER**10. (LN) REMOVE VENTURI ASSEMBLY**

- (a) Disconnect the connector and vacuum hoses from the VSV.
- (b) Remove the venturi assembly and gasket.
- (c) Remove the two bolts and wire support.

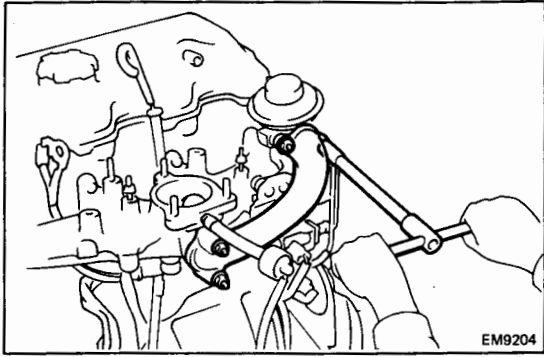

**11. (Austria)
REMOVE EGR VALVE, PIPE, VALVE ADAPTOR AND
CONTROL VALVE ASSEMBLY**

(a) Remove the four nuts, air pipe (LN only), EGR valve adaptor and two gaskets.

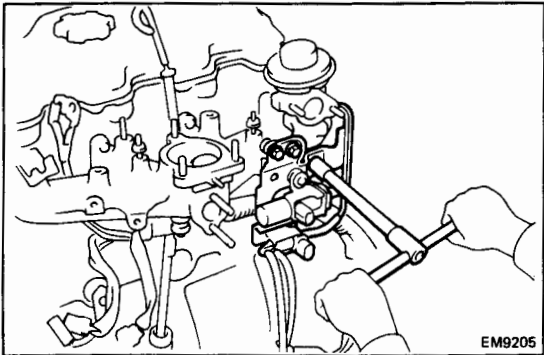

(b) Disconnect the connectors from the VSV and EVRV.

(c) Remove the three bolts and EGR control valve assembly.

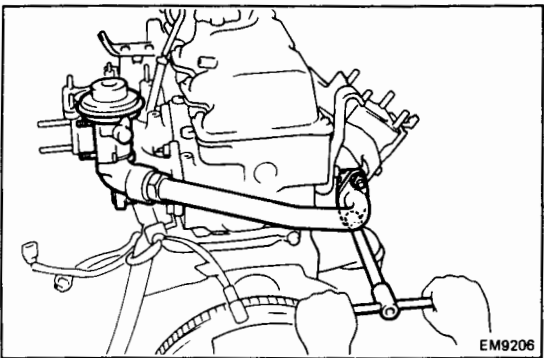

(d) Remove the two nuts, EGR valve with the pipe and gasket.

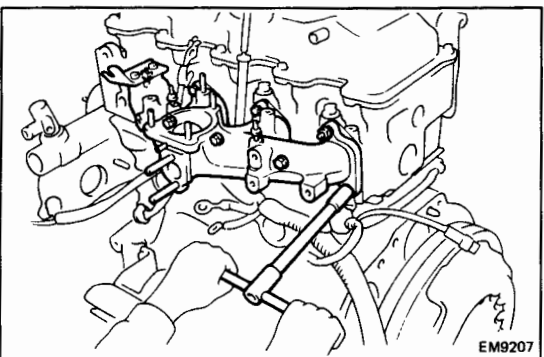

12. REMOVE INTAKE MANIFOLD

(a) Remove the nut and insulator of the glow plug resistor.

(b) Remove the six bolts, two nuts, intake manifold and gasket.

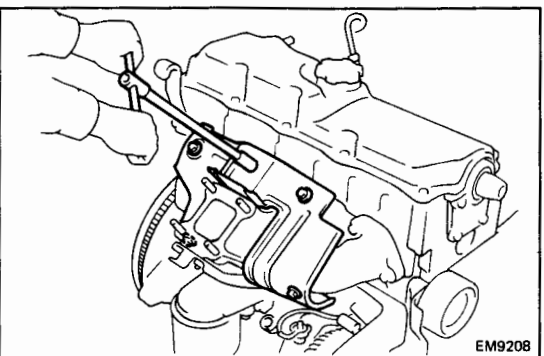

13. REMOVE EXHAUST MANIFOLD

(a) Remove the four bolts, nut and two heat insulators.

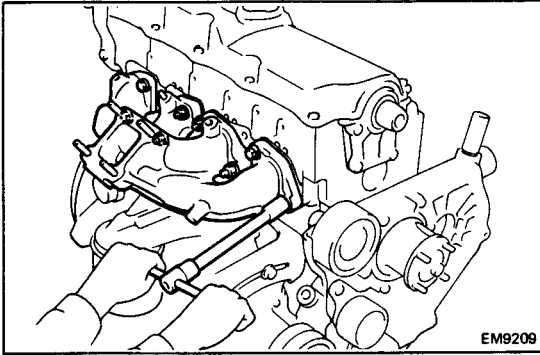

- (b) Remove the four bolts, four nuts, exhaust manifold and gasket.

14. REMOVE RH ENGINE HANGER

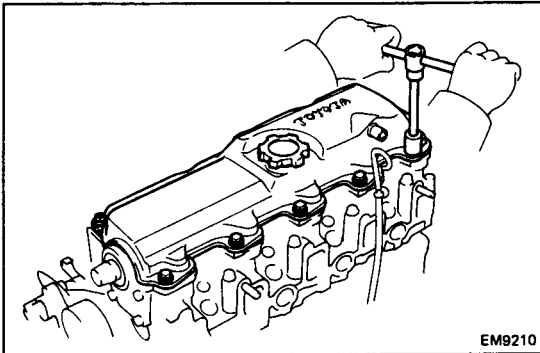

15. REMOVE CYLINDER HEAD COVER

- Remove the eight bolts, two nuts, cylinder head cover and gasket.

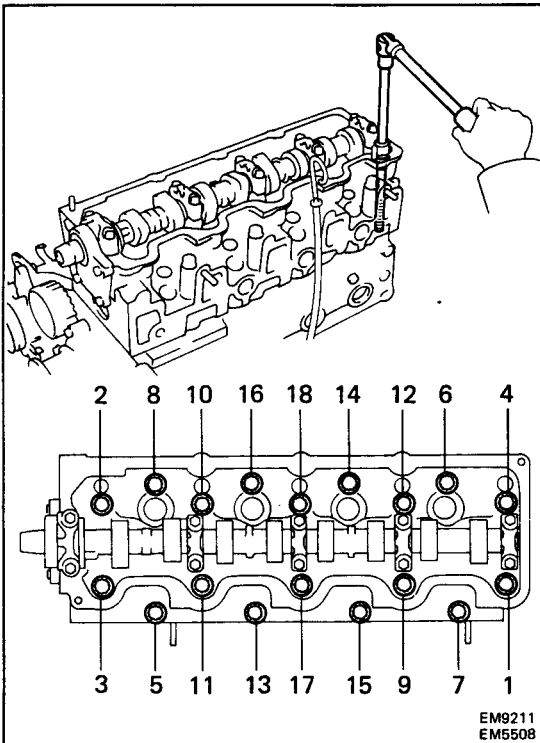

16. REMOVE CYLINDER HEAD

- (a) Uniformly loosen and remove the eighteen cylinder head bolts in several passes in the sequence shown.

NOTICE: Head warpage or cracking could result from removing bolts in incorrect order.

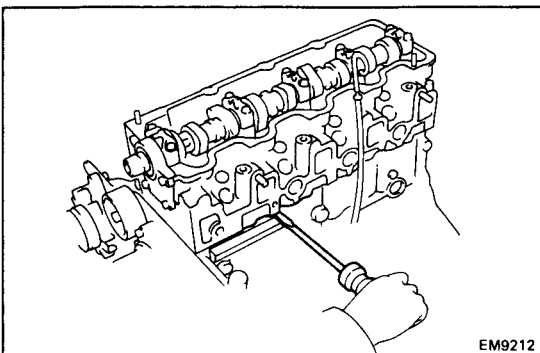

- (b) Lift the cylinder head from the dowels on the cylinder block and place the head on wooden blocks on a bench.

HINT: If the cylinder head is difficult to lift off, pry with a screwdriver between the cylinder head and block.

NOTICE: Be careful not to damage the cylinder head and cylinder block surfaces of cylinder head gasket side.

DISASSEMBLY OF CYLINDER HEAD

(See page EM-35)

INSPECTION, CLEANING AND REPAIR OF CYLINDER HEAD COMPONENTS**INSPECT CAMSHAFTS AND BEARINGS****B. Inspect cam lobes**

Using a micrometer, measure the cam lobe height.

Standard cam lobe height:

Intake	2L-T	53.450 – 53.470 mm (2.1043 – 2.1051 in.)
	3L	54.290 – 54.310 mm (2.1374 – 2.1382 in.)
Exhaust		54.990 – 55.010 mm (2.1650 – 2.1657 in.)

Minimum cam lobe height:

Intake	2L-T	52.95 mm (2.0846 in.)
	3L	53.79 mm (2.1177 in.)
Exhaust		54.49 mm (2.1453 in.)

If the cam lobe height is smaller than the minimum, replace the camshaft.

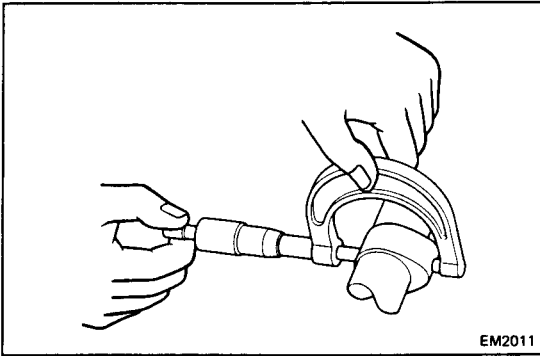

EM2011

ASSEMBLY OF CYLINDER HEAD

(See page EM-35)

INSTALL HALF CIRCULAR PLUG

- Remove any old packing (FIPG) material.
- Apply seal packing to the half circular plug as shown.

Seal packing: Part No. 08826-00080 or equivalent

- Install the half circular plug to the cylinder head.

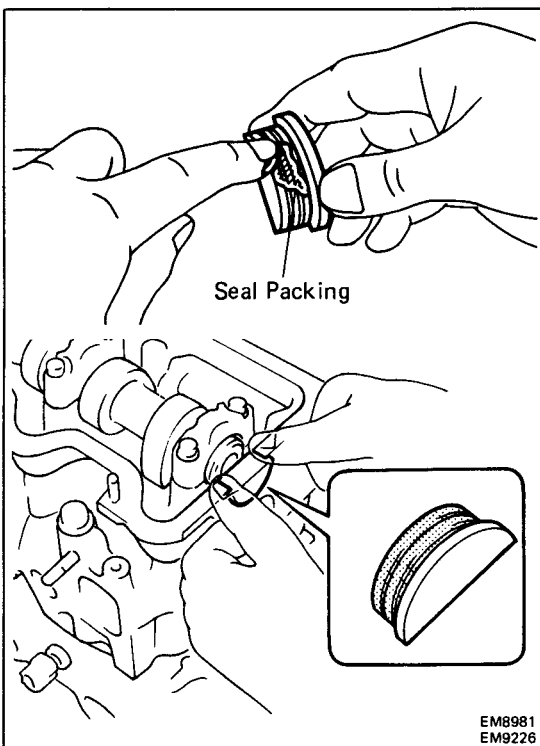
EM8981
EM9226

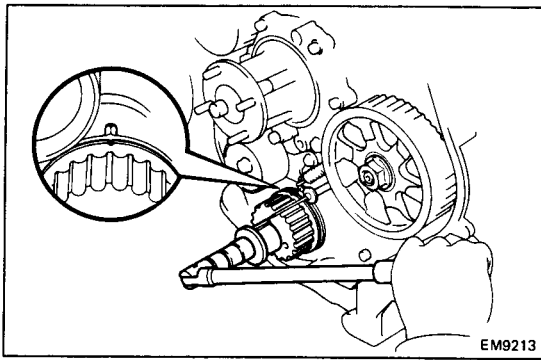

INSTALLATION OF CYLINDER HEAD

(See page EM-35)

1. CHECK PISTON PROTRUSION AND SELECT CYLINDER HEAD GASKET

A. Check protrusions of No. 1 and No. 4 pistons

(a) Align the timing marks of the crankshaft timing pulley and timing belt case.

(b) Place a dial indicator on the cylinder block, and set the dial indicator needle on the piston measuring point.

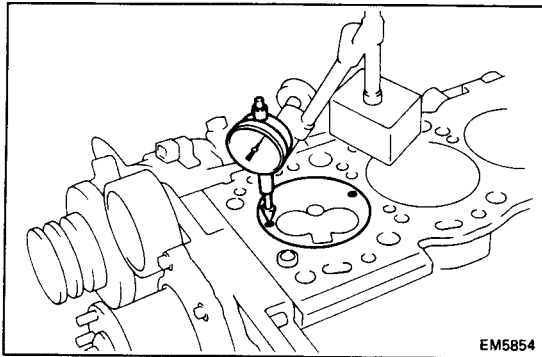

(c) Find where the piston head protrudes most by slowly turning the crankshaft clockwise and counterclockwise.

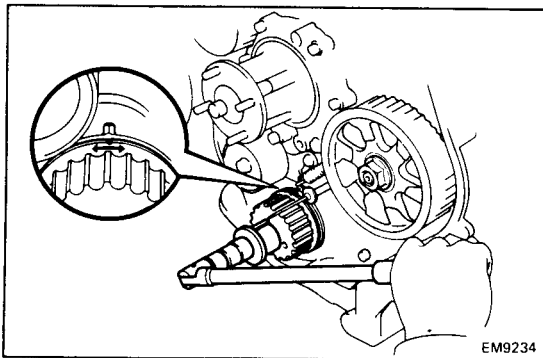

(d) Set the dial indicator at 0 mm (0 in.).

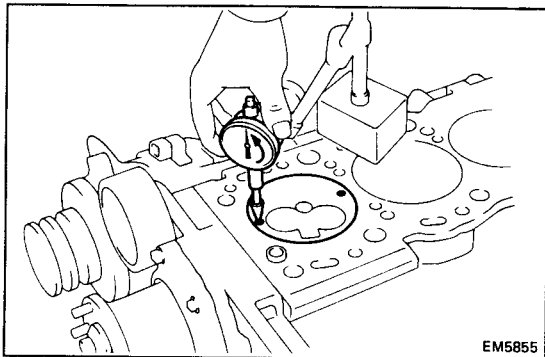

(e) Measure the piston protrusion from the cylinder block by sliding the dial indicator.

**Protrusion: 0.68 – 0.97 mm
(0.0268 – 0.0382 in.)**

HINT: For each piston, measure the piston protrusion at two measuring points.

(When removing piston and connecting rod assembly)

If the protrusion is not as specified, remove the piston and connecting rod assembly and reinstall it.

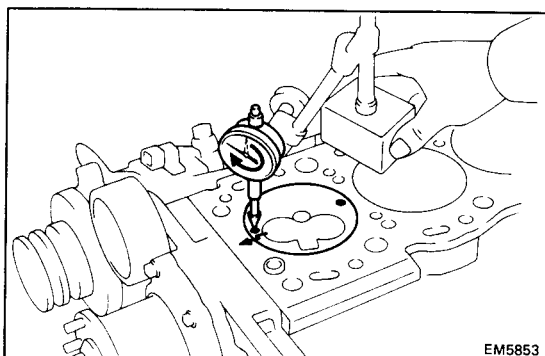

B. Check protrusions of No. 2 and No. 3 pistons

- (a) Turn the crankshaft 1/2 of a revolution (180°).
- (b) Measure the piston protrusions.
(See procedure steps A (b) to (e))

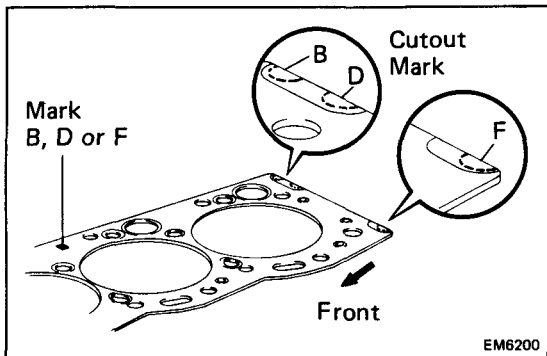

C. Select new cylinder head gasket

HINT: There are three sizes of new cylinder head gasket, marked either "B", "D" or "F", or indicated by a cutout mark.

New cylinder head gasket thickness:

- Mark B 1.40 – 1.50 mm
(0.0551 – 0.0591 in.)
- Mark D 1.50 – 1.60 mm
(0.0591 – 0.0630 in.)
- Mark F 1.60 – 1.70 mm
(0.0630 – 0.0669 in.)

When selecting a new cylinder head gasket, use the largest value from the eight measurements made of the piston protrusion.

HINT: There are 6 types of cylinder head gasket (marks A to F) installed at the factory, but only 3 types for supply parts (mark B, D and F), so when replacing the gasket, choose from one of the 3 types above.

Piston protrusion mm (in.)	Gasket size
0.68 – 0.77 (0.0268 – 0.0303)	Use B
0.78 – 0.87 (0.0307 – 0.0343)	Use D
0.88 – 0.97 (0.0316 – 0.0382)	Use F

2. SET NO. 1 CYLINDER TO TDC/COMPRESSION

HINT: Set the No. 1 cylinder to TDC/compression to avoid interference with the piston top and valve head.

- (a) (Camshaft Position)
Set the camshaft by turning the hexagonal wrench head portion, facing the key groove upward.

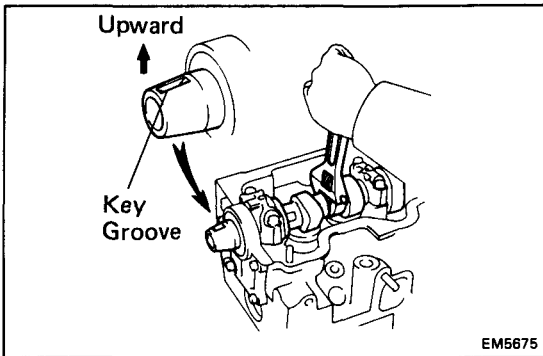

- (b) (Crankshaft Position)
Using the crankshaft pulley bolt, align the timing marks of the timing pulley and timing belt case by turning the crankshaft.

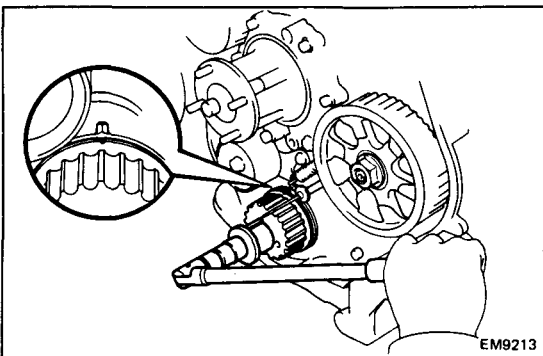

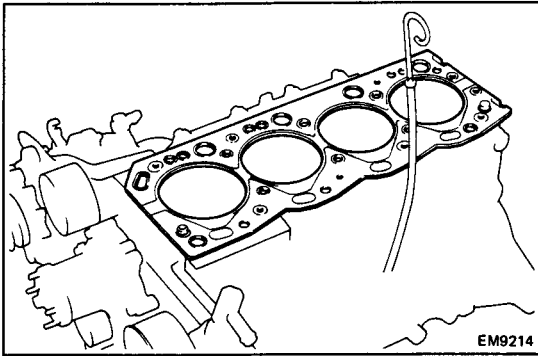

3. INSTALL CYLINDER HEAD

A. Place cylinder head on cylinder block

- (a) Place a new cylinder head gasket in position on the cylinder block.

NOTICE: Be careful of the installation direction.

- (b) Place the cylinder head in position on the cylinder head gasket.

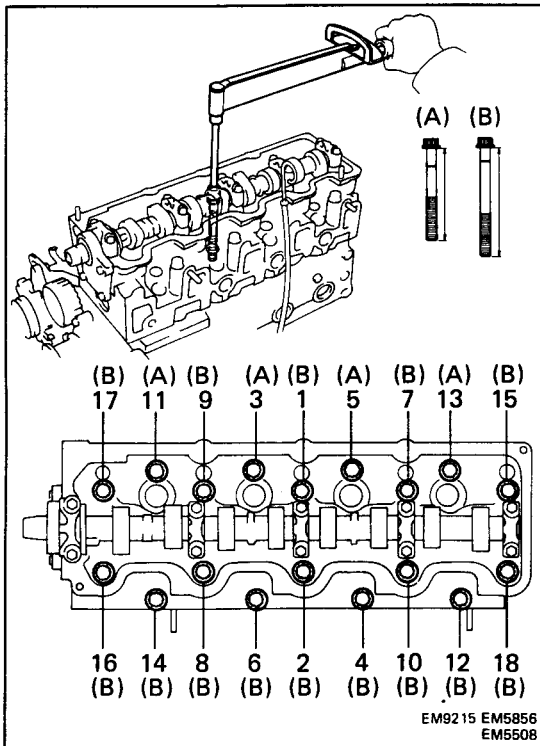

B. Install cylinder head bolts

HINT:

- The cylinder head bolts are tightened in three progressive steps.
 - If any of bolts break or deform, replace them.
- (a) Apply a light coat of engine oil on the threads and under the heads of the cylinder head bolts.
- (b) First, install and uniformly tighten the eighteen cylinder head bolts in several passes in the sequence shown.

Torque: 800 kg-cm (58 ft-lb, 78 N·m)

HINT: The bolt lengths for bolt types A and B shown in the illustration are:

A 107 mm (4.12 in.)

B 127 mm (5.00 in.)

If any one of the bolts does not meet the torque specification, replace the bolt.

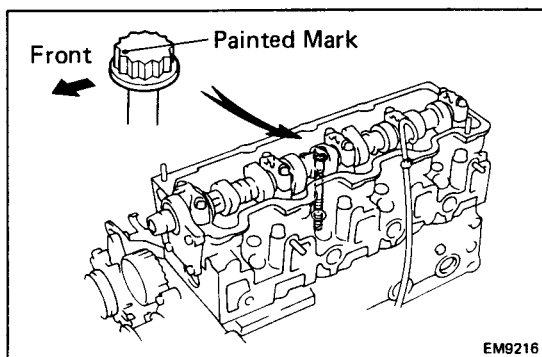

- (c) Mark the front of the cylinder head bolt with paint.

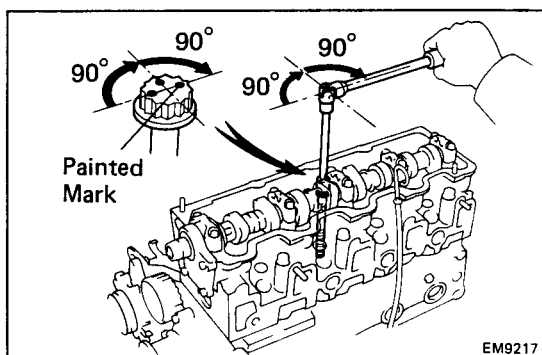

- (d) Second, retighten the cylinder head bolts 90° in the numerical order shown.

- (e) Third, retighten cylinder head bolts by an additional 90°.

- (f) Check that the painted mark is now facing rearward.

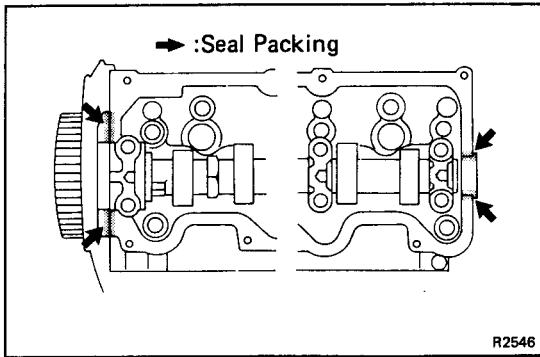

4. INSTALL CYLINDER HEAD COVER

- (a) Apply seal packing to the cylinder heads as shown in the illustration.

Seal packing: Part No. 08826-00080 or equivalent

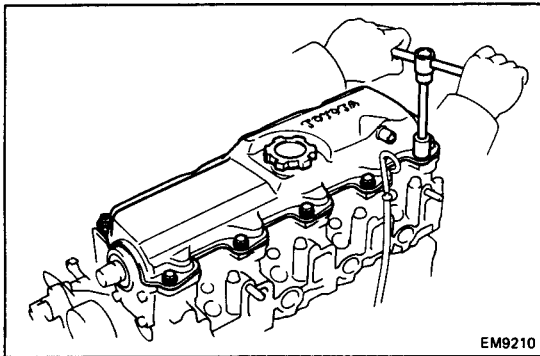

- (b) Install the gasket to the cylinder head cover.

- (c) Install the cylinder head cover with the eight bolts and two nuts.

Torque: 50 kg-cm (43 in.-lb, 4.9 N·m)

5. INSTALL RH ENGINE HANGER

Torque: 380 kg-cm (27 ft-lb, 37 N·m)

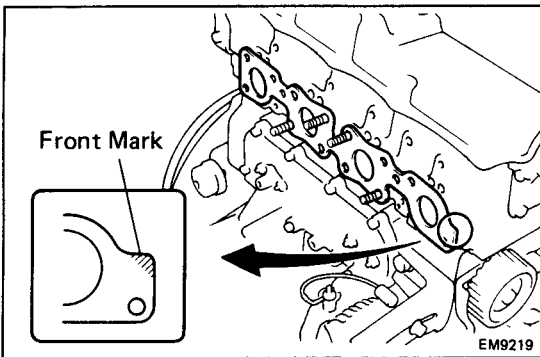

6. INSTALL EXHAUST MANIFOLD

- (a) Install a new gasket in direction as shown in the illustration.

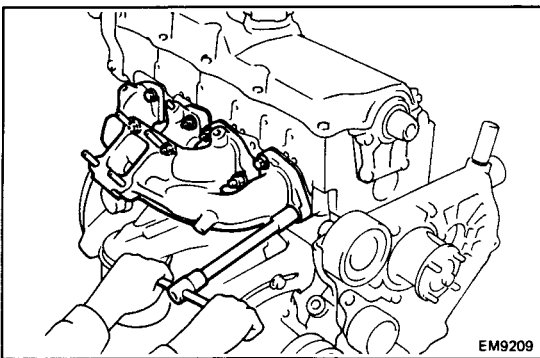

- (b) Install the exhaust manifold with the four nuts and four bolts.

Torque: 530 kg-cm (38 ft-lb, 52 N·m)

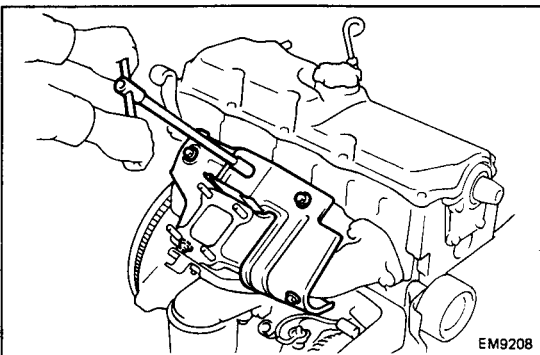

- (c) Install the two heat insulators with the four bolts and nut.

Torque: 120 kg-cm (9 ft-lb, 12 N·m)

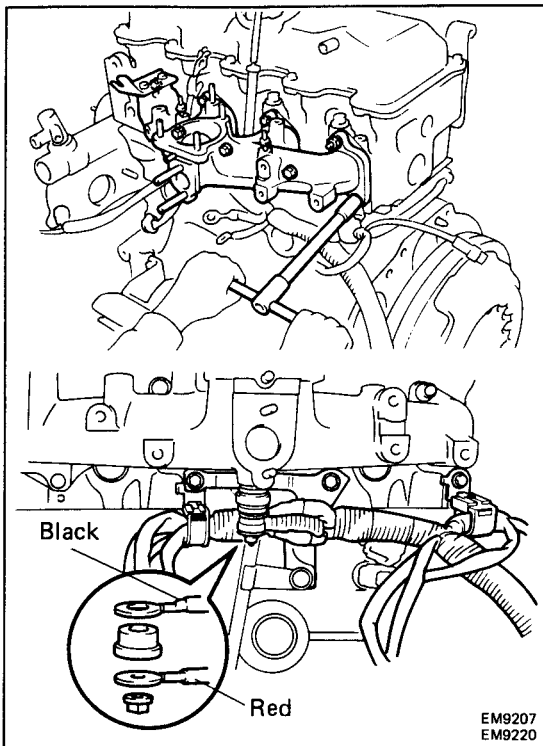

7. INSTALL INTAKE MANIFOLD

- (a) Install a new gasket and the intake manifold with the six bolts and two nuts.

Torque: 240 kg-cm (17 ft-lb, 24 N-m)

HINT: Torque the three bolts on the bottom of the manifold together with the oil level gauge guide support and the clamp for the engine wires, as shown in the illustration.

- (b) Install the insulator and nut to the glow plug resistor.

HINT: Install the insulator and engine wire terminals as shown in the illustration.

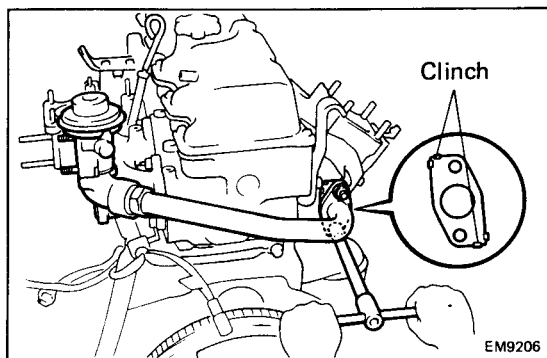

8. (Austria) INSTALL EGR VALVE, PIPE, VALVE ADAPTOR AND CONTROL VALVE ASSEMBLY

- (a) Place a new gasket in position on the intake manifold.

- (b) Install the EGR valve and pipe with the two nuts.

Torque: 130 kg-cm (9 in.-lb, 13 N-m)

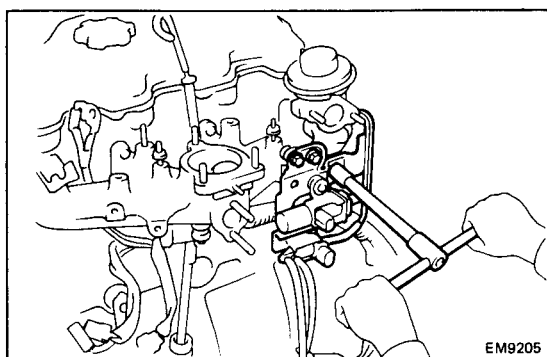

- (c) Install the EGR control valve assembly with the three bolts.

- (d) Connect the connectors to the VSV and EVRV.

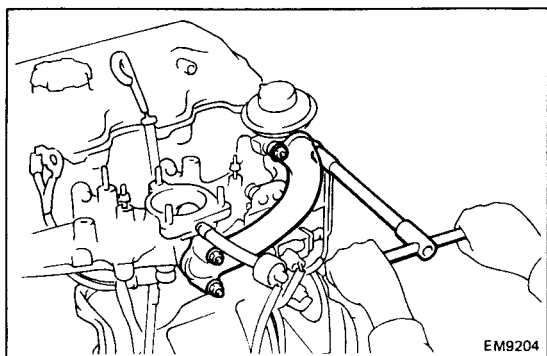

- (e) Install two new gaskets, the EGR valve adaptor and air pipe (LN only) with the four nuts.

Torque: 195 kg-cm (14 ft-lb, 19 N-m)

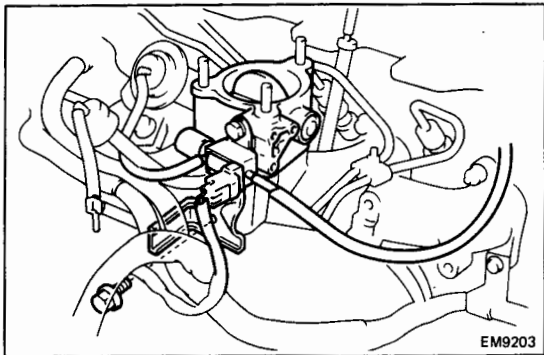

9. (LN)
INSTALL VENTURI ASSEMBLY
- Install the wire support with the two bolts.
 - Install a new gasket and the venturi assembly.
 - Connect the connector and vacuum hoses to the VSV.

10. **INSTALL LH ENGINE HANGER**
 Torque: 380 kg-cm (27 ft-lb, 37 N-m)



11. **INSTALL WATER OUTLET AND OUTLET HOUSING ASSEMBLY**
- Install a new gasket, the water outlet and outlet housing assembly with the three bolts.
- Torque: 195 kg-cm (14 ft-lb, 19 N-m)
- Connect the by-pass hose to the thermo wax of the injection pump.
 - Connect the water temperature switch connector.

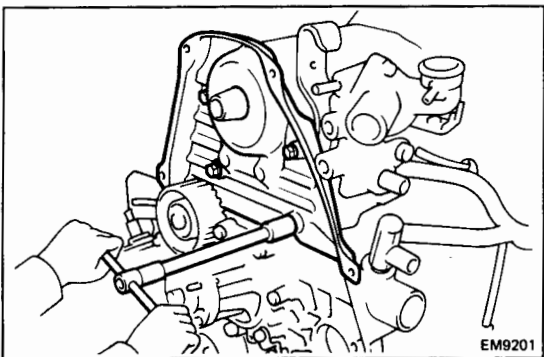

12. **INSTALL NO. 2 TIMING BELT COVER**
 Install the timing belt cover with the four bolts.
 Torque: 185 kg-cm (13 ft-lb, 18 N-m)

13. **INSTALL CAMSHAFT TIMING PULLEY**
14. **INSTALL INJECTION NOZZLES**
15. **INSTALL INJECTION PUMP**
 (See steps 2 to 11 on pages FU-46 and 47)
16. **INSTALL TIMING BELT**
 (See steps 12 to 18 on page FU-48)
17. **INSTALL TURBOCHARGER**
 (See steps 3 to 8 on pages TC-13 and 14)
18. **FILL WITH ENGINE COOLANT** (See page CO-5)
19. **START ENGINE AND CHECK FOR LEAKS**
20. **RECHECK ENGINE COOLANT LEVEL AND OIL LEVEL**

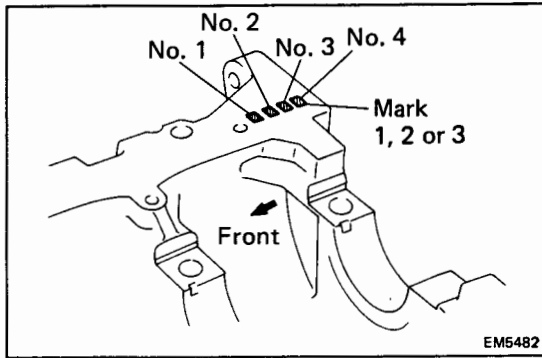

EM5482

CYLINDER BLOCK

INSPECTION OF CYLINDER BLOCK

INSPECT CYLINDER BORE DIAMETER

HINT: There are three sizes of the standard cylinder bore diameter, marked "1", "2" and "3" accordingly. The mark is stamped on the lower left rear of the cylinder block.

Using a cylinder gauge, measure the cylinder bore diameter at positions A, B and C in the thrust axial directions.

Standard diameter:

2L-T	STD mark "1"	92.000 – 92.010 mm (3.6220 – 3.6224 in.)
	STD mark "2"	92.010 – 92.020 mm (3.6224 – 3.6228 in.)
	STD mark "3"	92.020 – 92.030 mm (3.6228 – 3.6232 in.)
3L	STD mark "1"	96.000 – 96.010 mm (3.7795 – 3.7799 in.)
	STD mark "2"	96.010 – 96.020 mm (3.7799 – 3.7803 in.)
	STD mark "3"	96.020 – 96.030 mm (3.7803 – 3.7807 in.)

Maximum diameter:

2L-T	STD	92.23 mm (3.6311 in.)
	O/S 0.50	92.73 mm (3.6508 in.)
3L	STD	96.23 mm (3.7886 in.)
	O/S 0.50	96.73 mm (3.8083 in.)

If the diameter is greater than maximum, rebore all four cylinders. If necessary, replace the cylinder block.

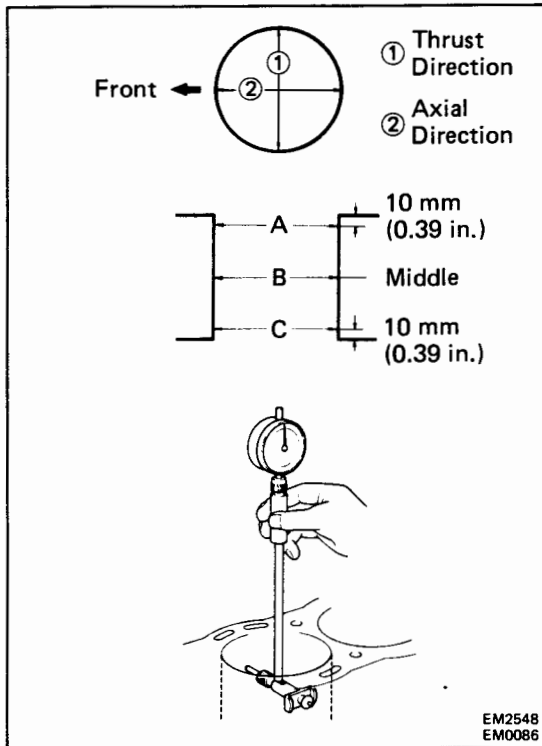
EM2548
EM0086

INSPECTION OF PISTON AND CONNECTING ROD ASSEMBLIES

1. INSPECT PISTON DIAMETER AND OIL CLEARANCE

HINT: There are three sizes of the standard piston diameter, marked "1", "2" and "3" accordingly. The mark is stamped on the top of the piston.

- (a) Using a micrometer, measure the piston diameter at right angles to the piston pin center line, the indicated distance from the piston head.

Distance:

2L-T	58.27 – 58.33 mm (2.2941 – 2.2965 in.)
3L	56.27 – 56.33 mm (2.2153 – 2.2177 in.)

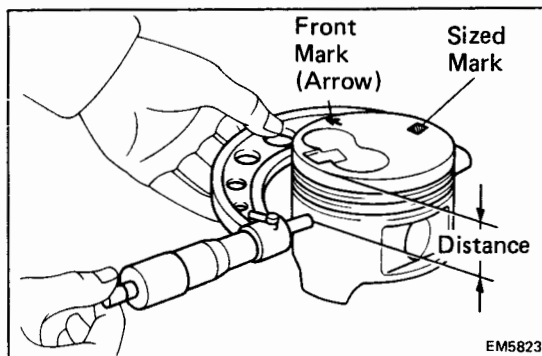

EM5823

Piston diameter:

2L-T STD mark "1"	91.940 – 91.950 mm (3.6197 – 3.6201 in.)
STD mark "2"	91.950 – 91.960 mm (3.6201 – 3.6205 in.)
STD mark "3"	91.960 – 91.970 mm (3.6205 – 3.6209 in.)
O/S 0.50	92.440 – 92.470 mm (3.6394 – 3.6405 in.)

Piston diameter:

3L STD mark "1"	95.940 – 95.950 mm (3.7772 – 3.7776 in.)
STD mark "2"	95.950 – 95.960 mm (3.7776 – 3.7779 in.)
STD mark "3"	95.960 – 95.970 mm (3.7779 – 3.7783 in.)
O/S 0.50	96.440 – 96.470 mm (3.7968 – 3.7980 in.)

- (b) Measure the cylinder bore diameter in the thrust directions. (See page EM-46)
- (c) Subtract the piston diameter measurement from the cylinder bore diameter measurement.

Standard oil clearance: 0.050 – 0.070 mm
(0.0020 – 0.0028 in.)

Maximum oil clearance: 0.14 mm (0.0055 in.)

If the oil clearance is greater than maximum, replace all four pistons and rebore all four cylinders. If necessary, replace the cylinder block.

HINT (Use cylinder block subassembly): When installing a standard piston, install one with the same number mark as the standard bore diameter mark on the cylinder block.

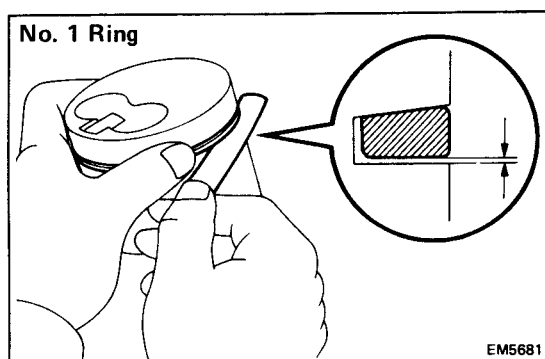
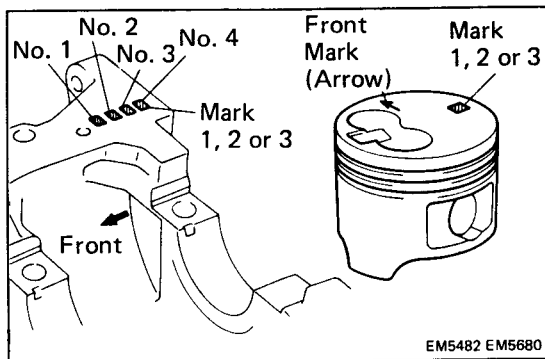

2. INSPECT CLEARANCE BETWEEN WALL OF RING GROOVE AND NEW PISTON RING

(No. 1 Ring)

Install a No. 1 piston ring to the piston. Using a feeler gauge, measure the clearance between the piston ring and wall of the piston ring groove.

Standard ring groove clearance:

No. 1 0.028 – 0.077 mm (0.0011 – 0.0030 in.)

Maximum ring groove clearance: 0.20 mm (0.008 in.)

If the clearance is greater than maximum, replace the piston.

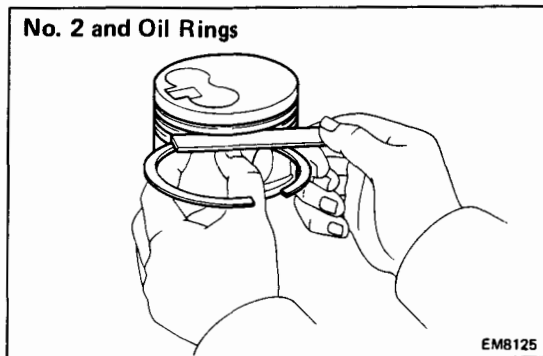
**(No.2 and Oil Rings)**

Using a feeler gauge, measure the clearance between new piston ring and the wall of the piston ring groove.

Standard ring groove clearance:

No. 2	2L-T	0.070 – 0.115 mm (0.0028 – 0.0045 in.)
	3L	0.060 – 0.105 mm (0.0024 – 0.0041 in.)
Oil		0.030 – 0.070 mm (0.0012 – 0.0028 in.)

Maximum ring groove clearance: 0.20 mm (0.008 in.)

If the clearance is greater than maximum, replace the piston.

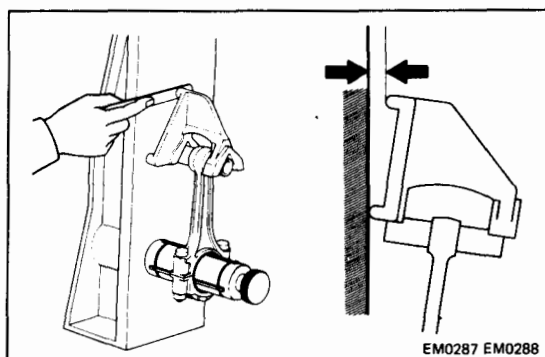
**3. INSPECT CONNECTING ROD****A. Inspect connecting rod alignment**

Using a rod aligner, check the connecting rod alignment.

- Check for bending.

Maximum bending:

0.05 mm (0.0020 in.) per 100 mm (3.94 in.)

If bent is greater than maximum, replace the connecting rod assembly.

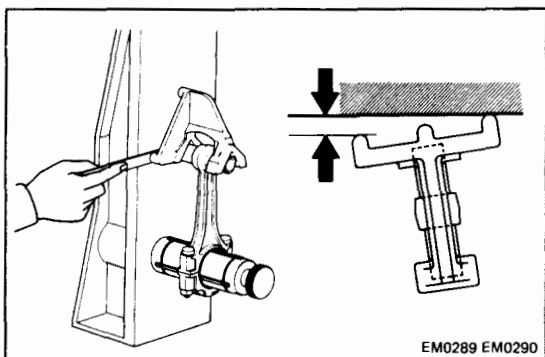

- Check for twist.

Maximum twist:

0.15 mm (0.0059 in.) per 100 mm (3.94 in.)

If twist is greater than maximum, replace the connecting rod assembly.

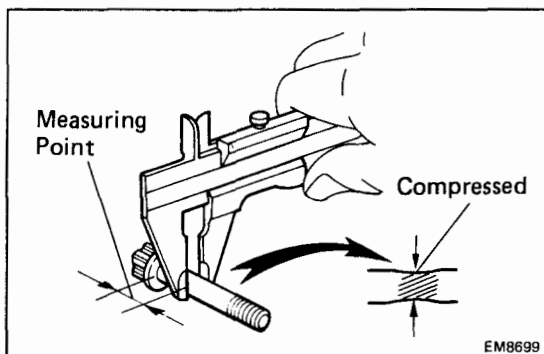
**B. Inspect connecting rod bolts**

Using vernier calipers, measure the minimum diameter of the compressed bolt at the measuring point.

**Standard diameter: 8.400 – 8.600 mm
(0.3307 – 0.3386 in.)**

Minimum diameter: 8.20 mm (0.3228 in.)

If the diameter is less than minimum, replace the connecting rod bolt.

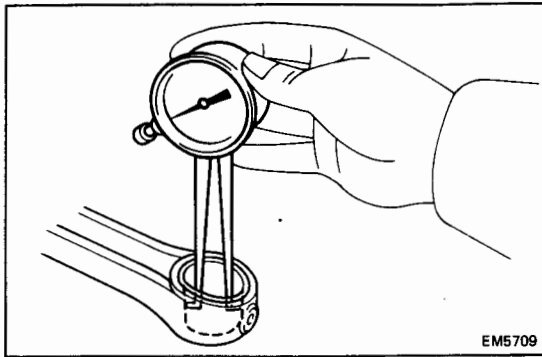
**C. Inspect piston pin oil clearance**

- (a) Using a caliper gauge, measure the inside diameter of the connecting rod bushing.

Bushing inside diameter:

29.008 – 29.020 mm (1.1420 – 1.1425 in.)

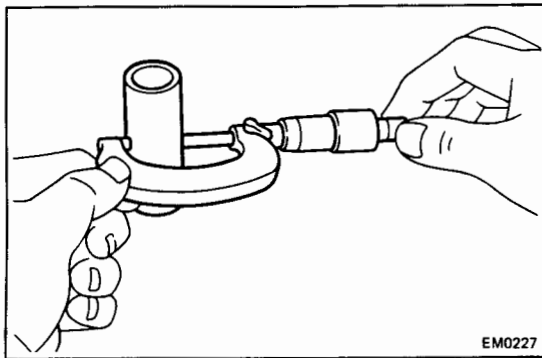

- (b) Using a micrometer, measure the piston pin diameter.

Piston pin diameter:

29.000 – 29.012 mm (1.1417 – 1.1422 in.)

- (c) Subtract the piston pin diameter measurement from the bushing inside diameter measurement.

Standard oil clearance: 0.004 – 0.012 mm
(0.0002 – 0.0005 in.)

Maximum oil clearance: 0.05 mm (0.0020 in.)

BORING OF CYLINDERS**HINT:**

- Bore all four cylinders for the oversized piston outside diameter.
- Replace the piston rings with ones to match the oversized pistons.

1. KEEP OVERSIZED PISTONS

Oversized (O/S 0.50) piston diameter:

2L-T 92.440 – 92.470 mm (3.6394 – 3.6405 in.)

3L 96.440 – 96.470 mm (3.7968 – 3.7980 in.)

2. CALCULATE AMOUNT TO BORE CYLINDER

- (a) Using a micrometer, measure the piston diameter at right angles to the piston pin center line, the indicated distance from the piston head.

Distance:

2L-T 58.27 – 58.33 mm (2.2941 – 2.2965 in.)

3L 56.27 – 56.33 mm (2.2153 – 2.2177 in.)

- (b) Calculate the amount each cylinder is to be rebored as follows:

Size to be rebored = P + C – H

P = Piston diameter

C = Piston oil clearance

0.05 – 0.07 mm (0.0020 – 0.0028 in.)

H = Allowance for honing

0.02 mm (0.0008 in.) or less

3. BORE AND HONE CYLINDERS TO CALCULATED DIMENSIONS

Maximum honing: 0.02 mm (0.0008 in.)

NOTICE: Excess honing will destroy the finished roundness.

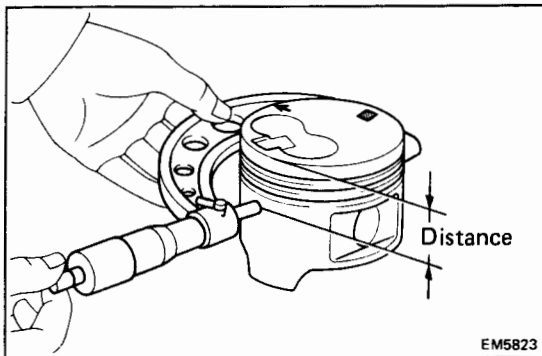

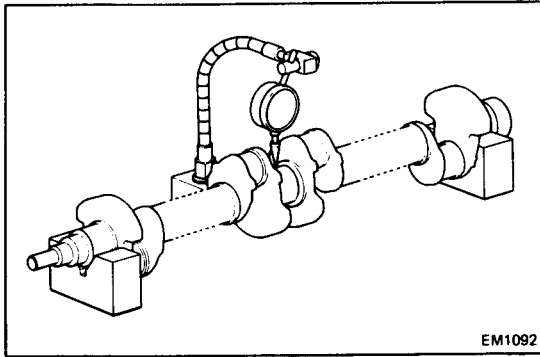

EM1092

INSPECTION AND REPAIR OF CRANKSHAFT

1. INSPECT CRANKSHAFT FOR RUNOUT

- (a) Place the crankshaft on V-blocks.
- (b) Using a dial indicator, measure the circle runout at the center journal.

Maximum circle runout: 0.06 mm (0.0024 in.)

If the circle runout is greater than maximum, replace the crankshaft.

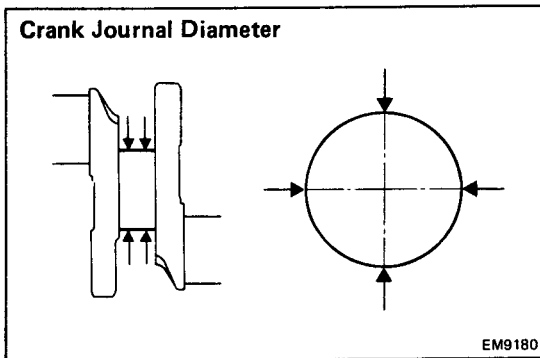

EM9180

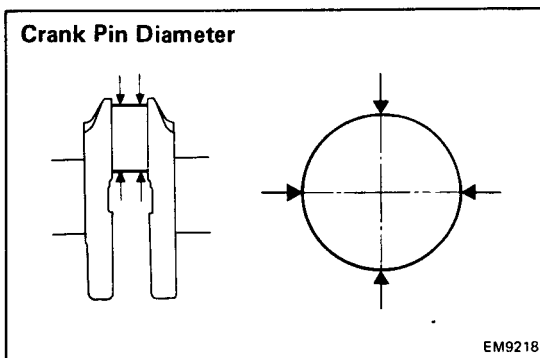

EM9218

2. INSPECT MAIN JOURNALS AND CRANK PINS

- (a) Using a micrometer, measure the diameter of each main journal and crank pin.

Main journal diameter:

STD	61.985 – 62.000 mm (2.4403 – 2.4409 in.)
U/S 0.25	61.745 – 61.755 mm (2.4309 – 2.4313 in.)
U/S 0.50	61.495 – 61.505 mm (2.4211 – 2.4215 in.)

Crank pin diameter:

STD	54.988 – 55.000 mm (2.1649 – 2.1654 in.)
U/S 0.25	54.745 – 54.755 mm (2.1553 – 2.1557 in.)
U/S 0.50	54.495 – 54.505 mm (2.1455 – 2.1459 in.)

If the diameter is not as specified, check the oil clearance.

- (b) Check each main journal and crank pin for taper and out-of-round as shown.

**Maximum taper and out-of-round: 0.02 mm
(0.0008 in.)**

If the taper or out-of-round is greater than maximum, grind or replace the crankshaft.

3. IF NECESSARY, GRIND AND HONE MAIN JOURNALS AND/OR CRANK PINS

Grind and hone the main journals and/or crank pins to the finished undersized diameter (See procedure step 2).

Install new main journal and/or crank pin undersized bearings.

ASSEMBLY OF CYLINDER BLOCK

The connecting rod cap nut tightening torque has been changed as follows:

Torque:

Previous	1st	550 kg-cm (40 ft-lb, 54 N·m)
	2nd	90° turns
		↓
New	1st	350 kg-cm (25 ft-lb, 34 N·m)
	2nd	120° turns

TURBOCHARGER SYSTEM

	Page
DESCRIPTION	TC-2
PRECAUTIONS	TC-4
TROUBLESHOOTING	TC-5
TURBOCHARGER ELECTRICAL SYSTEM	
DIAGNOSIS	TC-7
TURBOCHARGER	TC-8

TC

DESCRIPTION

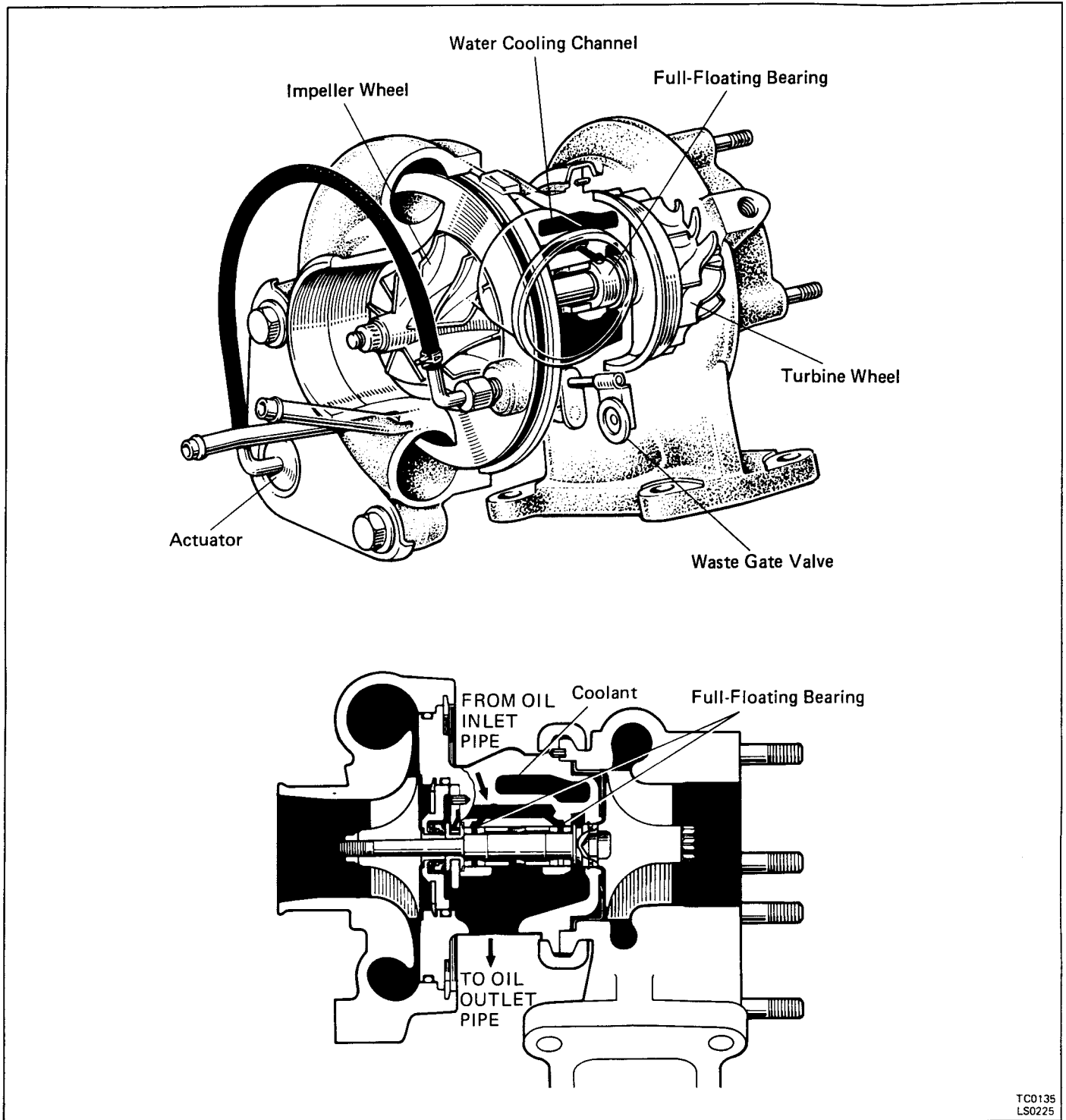
TC0135
LS0225

Systems which increase the amount of air sent to the engine are either turbocharger type (using exhaust gas to turn the turbine) or supercharger type (using the engine crankshaft, etc. to mechanically turn the pump, etc.). For LAND CRUISER and 4RUNNER 2L-T engine, the turbocharger type has been adopted.

The turbocharger is a device which increases engine output by introducing a greater amount of

air to the engine. This allows a proportional increase in the fuel that can be burned and hence raises the potential power output.

In other words, by installing a special turbocharger and providing a higher air than usual, engine output can be increased by increasing the average combustion pressure without increasing the engine speed.

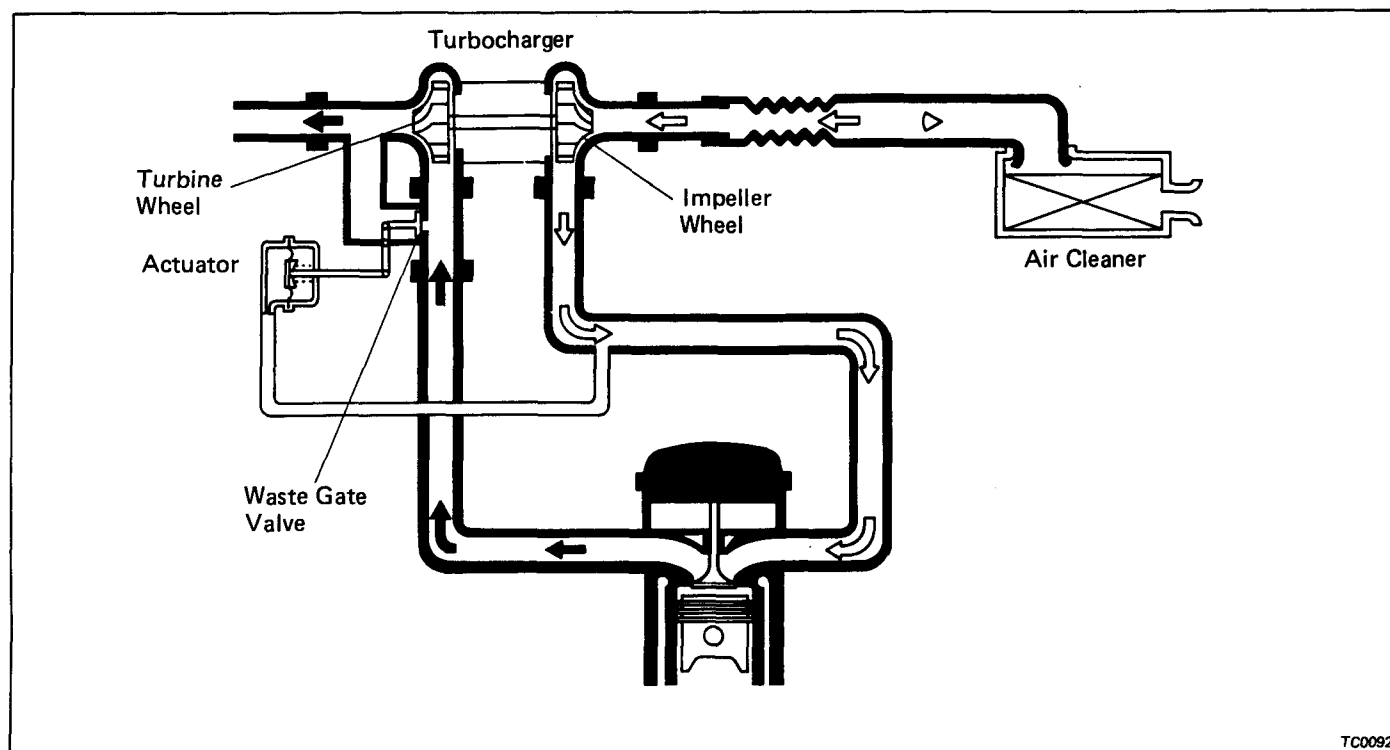

TC0092

Operation of Turbocharger

Exhaust gas acts on the turbine wheel inside the turbine housing, causing it to revolve. When the turbine wheel revolves, the impeller wheel which is located on the same shaft also revolves, compressing the intake air which has passed through the air cleaner. When expelled from the compressor housing the compressed air is supplied to the cylinders. When the engine speed increases, the exhaust gas volume increases and the turbine wheel revolutions increase (approx. 20,000 – 115,000 rpm), thus the turbocharged air pressure grows greater and engine output increases.

Waste Gate Valve

If the turbocharged air pressure exceeds the prescribed air pressure, the flow of exhaust gas by-passes the turbine, controlling turbine wheel revolutions and turbocharged air pressure. This by-pass valve which controls the quantity of exhaust gas flowing to the turbine is called the waste gate valve. When the charged air pressure exceeds the prescribed pressure, the actuator operates, the waste gate valve opens and part of the exhaust gas by-passes the turbine. This causes a drop in the turbine revolution rate and controls the charged air pressure within the prescribed limits.

PRECAUTIONS

1. Do not stop the engine immediately after pulling a trailer or high speed or uphill driving. Idle the engine for 20 — 120 seconds, depending on the severity of the driving condition.
2. Avoid sudden racing or acceleration immediately after starting a cold engine.
3. If the turbocharger is defective and must be replaced, first check for the cause of the defect in reference to the following items and replace parts if necessary:
 - Engine oil level and quality
 - Conditions under which the turbocharger was used
 - Oil lines leading to the turbocharger

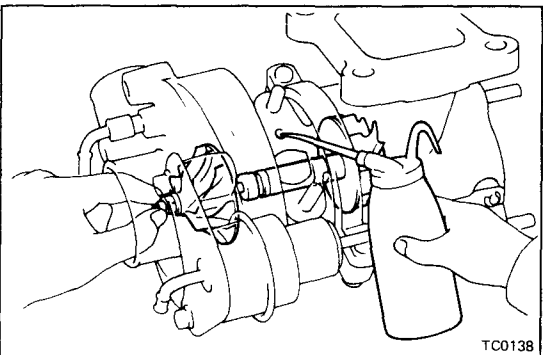
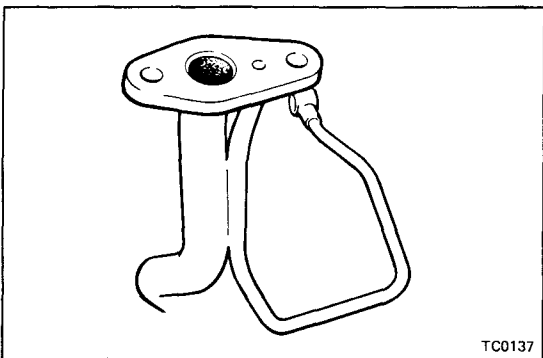
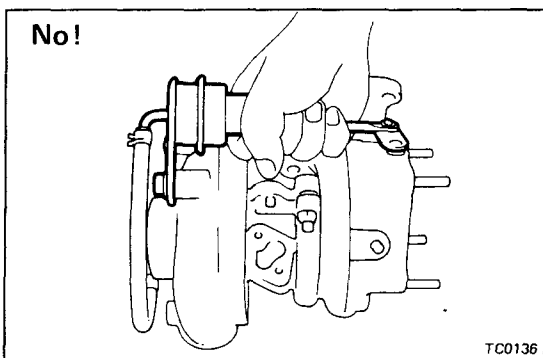

4. Use caution when removing and reinstalling the turbocharger assembly. Do not drop it or bang it against anything or grasp it by easily-deformed parts, such as the actuator or rod, when moving it.
5. Before removing the turbocharger, plug the intake and exhaust ports and oil inlet to prevent entry of dirt or other foreign material.
6. If replacing the turbocharger, check for accumulation of sludge particles in the oil pipes and, if necessary, replace the oil pipes.
7. Completely remove the gasket adhered to the lubrication oil pipe flange and turbocharger oil flange.
8. If replacing bolts or nuts, do so only with the specified new ones to guard against breakage or deformation.
9. If replacing the turbocharger, put 20 cc (1.2 cu in.) of oil into the turbocharger oil inlet and turn the impeller wheel by hand to spread oil to the bearing.
10. If overhauling or replacing the engine, cut the fuel supply after reassembly and crank the engine for 30 seconds to distribute oil throughout the engine. Allow the engine to idle for 60 seconds.

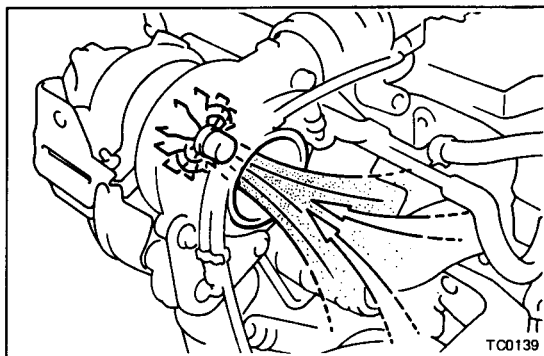

11. If the engine is running with the air cleaner, case cover and hose removed, entry of foreign particles will damage the wheels which run at extremely high speed.

TROUBLESHOOTING

HINT: Before troubleshooting the turbocharger, first check the engine itself. (Valve clearance, engine compression, injection timing etc.)

INSUFFICIENT ACCELERATION, LACK OF POWER OR EXCESSIVE FUEL CONSUMPTION

(Possible Cause)	(Check Procedure and Correction Method)
1. TURBOCHARGING PRESSURE TOO LOW	Check turbocharging pressure. (See page TC-8) Turbocharging pressure: 0.61 – 0.81 kg/cm ² (8.7 – 11.5 psi, 60 – 79 kPa) If the pressure is below specification, begin diagnosis from item 2.
2. RESTRICTED INTAKE AIR SYSTEM	Check intake air system, and repair or replace parts as necessary. (See page TC-8)
3. LEAK IN INTAKE AIR SYSTEM	Check intake air system, and repair or replace parts as necessary. (See page TC-8)
4. RESTRICTED EXHAUST SYSTEM	Check exhaust system, and repair or replace parts as necessary. (See page TC-8)
5. LEAK IN EXHAUST SYSTEM	Check exhaust system, and repair or replace parts as necessary. (See page TC-8)
6. ERRATIC TURBOCHARGER OPERATION	Check rotation of impeller wheel. If it does not turn or turns with a heavy drag, replace the turbocharger assembly. Check plays of turbine shaft. (See page TC-12) Axial play: 0.13 mm (0.0051 in.) or less Radial play: 0.18 mm (0.0071 in.) or less If not within specification, replace the turbocharger assembly.

ABNORMAL NOISE

(Possible Cause)**(Check Procedure and Correction Method)**

**1. TURBOCHARGER INSULATOR
RESONANCE**

Check for loose, improperly installed or deformed insulator mounting bolts and nuts, and repair or replace as necessary.

**2. EXHAUST PIPE LEAKING OR
VIBRATING**

Check for exhaust pipe deformation, loose mounting bolts or a damaged gasket, and repair or replace as necessary.

**3. ERRATIC TURBOCHARGER
OPERATION**

Refer to item 6 of INSUFFICIENT ACCELERATION, LACK OF POWER OR EXCESSIVE FUEL CONSUMPTION.

EXCESSIVE OIL CONSUMPTION OR WHITE EXHAUST

(Possible Cause)**(Check Procedure and Correction Method)**

FAULTY TURBOCHARGER OIL SEAL

Check for oil leakage in exhaust system.

- Remove the turbine elbow from the turbocharger and check for excessive carbon deposits on the turbine wheel. Excessive carbon deposits would indicate a faulty turbocharger.

Check for oil leakage in intake air system.

- Check plays of turbine shaft, and replace the turbocharger if necessary. (See page TC-12)

Axial play: 0.13 mm (0.0051 in.) or less

Radial play: 0.18 mm (0.0071 in.) or less

TURBOCHARGER ELECTRICAL SYSTEM DIAGNOSIS

TROUBLESHOOTING OF TURBOCHARGER INDICATOR LIGHT AND WARNING LIGHT OPERATION

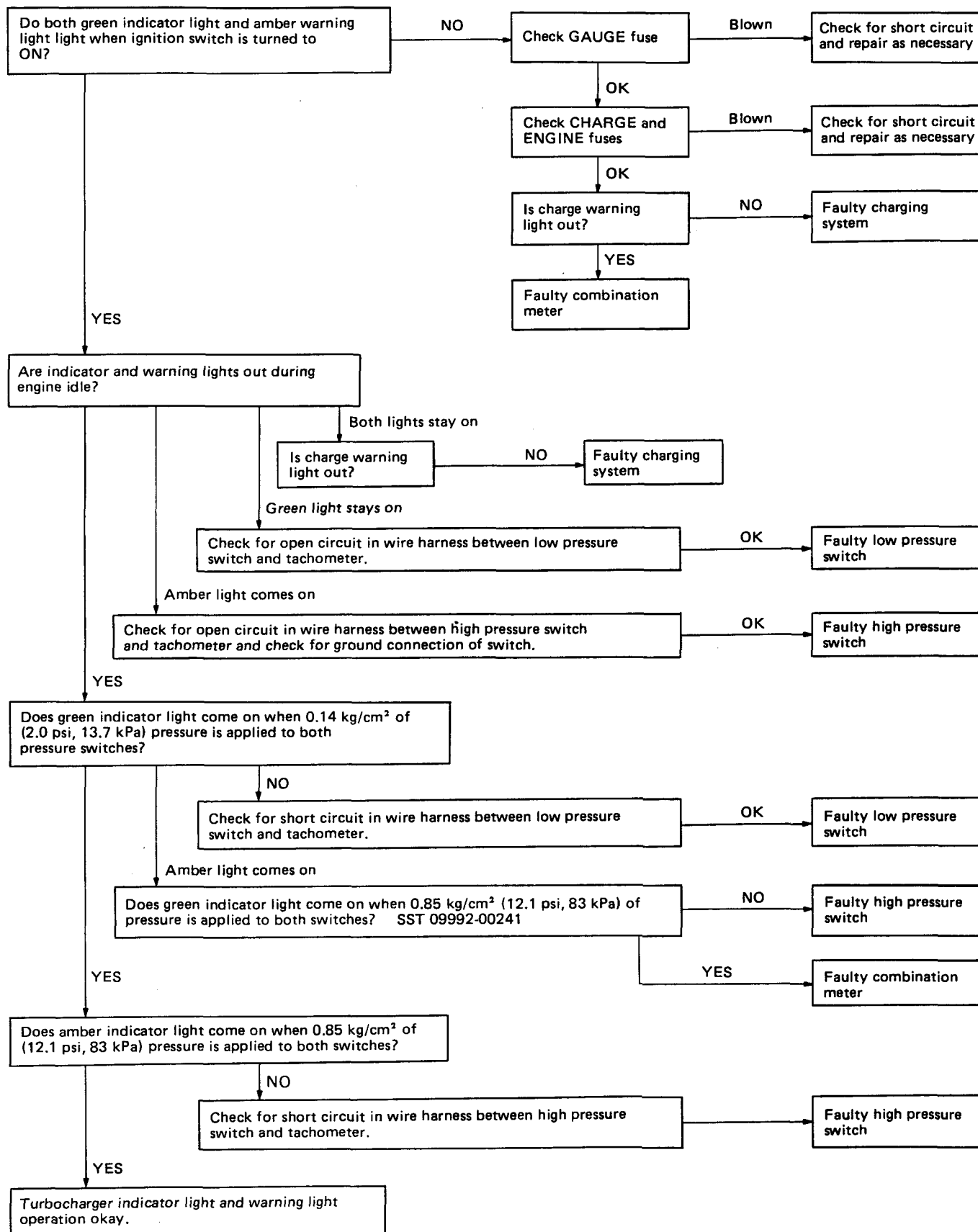

TURBOCHARGER

ON-VEHICLE INSPECTION OF TURBOCHARGER

1. INSPECT INTAKE AIR SYSTEM

Check for leakage or clogging between the air cleaner and turbocharger inlet and between the turbocharger outlet and cylinder head.

- Clogged air cleaner Clean or replace the element
- Hoses collapsed or deformed Check each connection and repair
- Cracks in components Check and replace

2. INSPECT EXHAUST SYSTEM

Check for leakage or clogging between the cylinder head and turbocharger inlet and between the turbocharger outlet and exhaust pipe.

- Deformed components Repair or replace
- Foreign material in passages Remove
- Leakage from components Repair or replace
- Cracks in components Check and replace

3. CHECK TURBOCHARGING PRESSURE

- (a) Warm up the engine.
- (b) Connect a 3-way union to the intake pipe pressure hose and install SST (turbocharger pressure gauge) to it.

SST 09992-00241

- (b) Press in the clutch pedal, then press the accelerator pedal down as far as it will go. Measure the turbocharging pressure at 2,400 rpm or more.

**Standard pressure: 0.61 – 0.81 kg/cm²
(8.7 – 11.5 psi, 60 – 79 kPa)**

If the pressure is less than specification, check the intake air and exhaust systems for leakage. If there is no leakage, replace the turbocharger assembly.

If the pressure is above specification, check if the actuator hose is disconnected or cracked. If not, replace the turbocharger assembly.

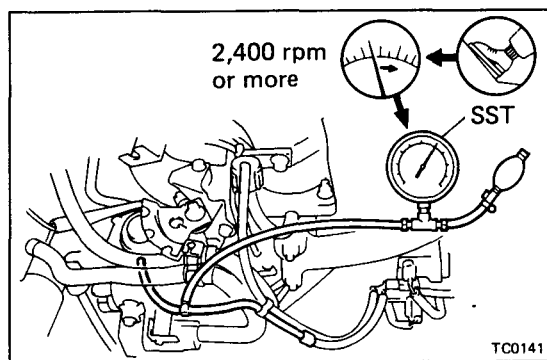

4. INSPECT IMPELLER WHEEL ROTATION

- (a) Disconnect the air cleaner hose.
- (b) Grasp the edge of the impeller wheel and turn it. Check that it turns smoothly.

If it does not turn or if it turns with a drag, replace the turbocharger assembly.

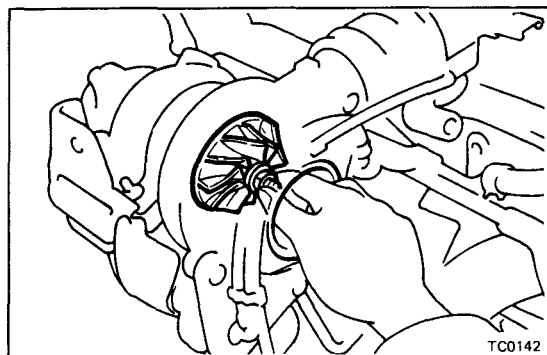

COMPONENTS

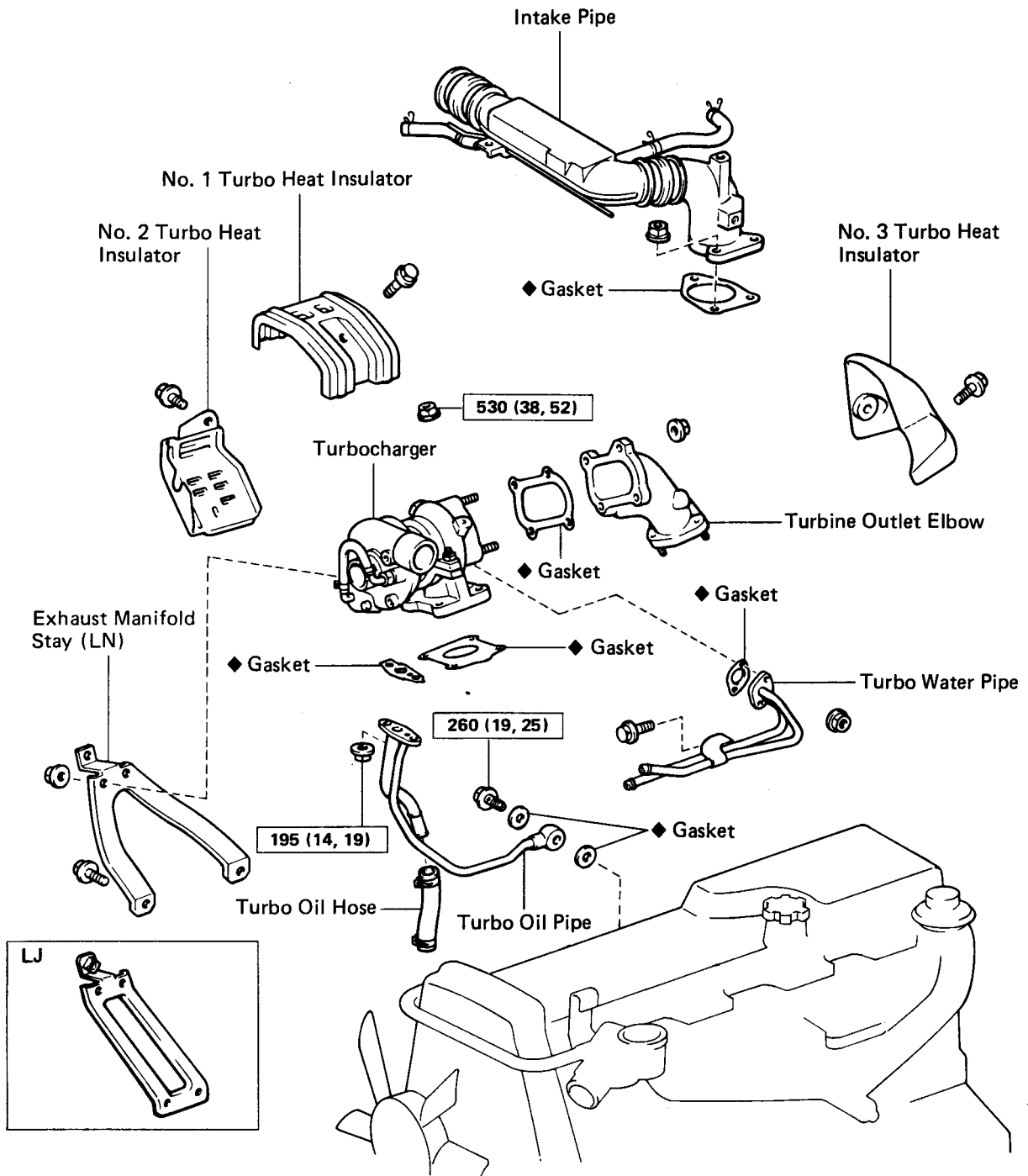

kg-cm (ft-lb, N·m) : Specified torque

◆ Non-reusable part

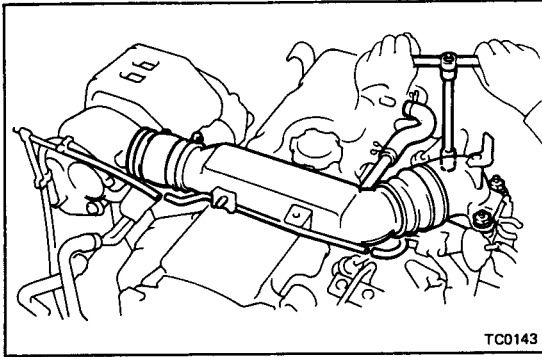

REMOVAL OF TURBOCHARGER

(See page TC-9)

1. DRAIN ENGINE COOLANT (See page CO-4)
2. REMOVE INTAKE PIPE
 - (a) Disconnect the vacuum hoses for the boost compensator.
 - (b) Disconnect the air hose clamp bolt.
 - (c) Remove the three nuts, intake pipe and gasket.
3. DISCONNECT WATER BY-PASS HOSES

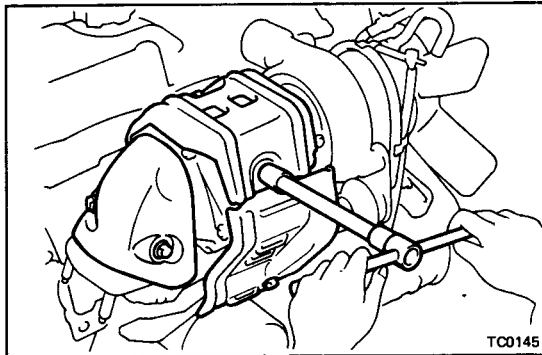
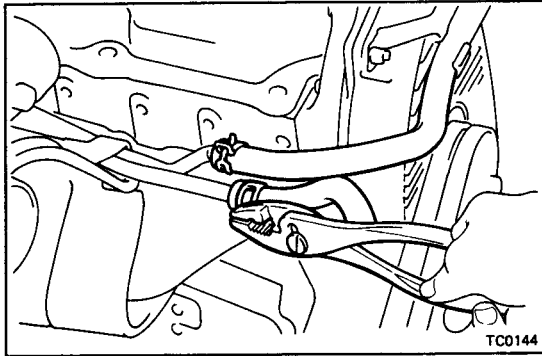

4. REMOVE TURBO HEAT INSULATORS

Remove the four bolts and three heat insulators.

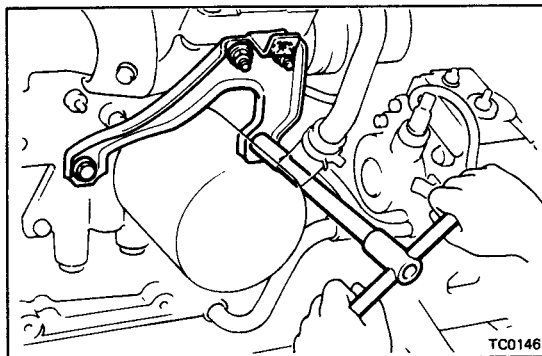

5. REMOVE EXHAUST MANIFOLD STAY

Remove the two bolts, two nuts and exhaust manifold stay.

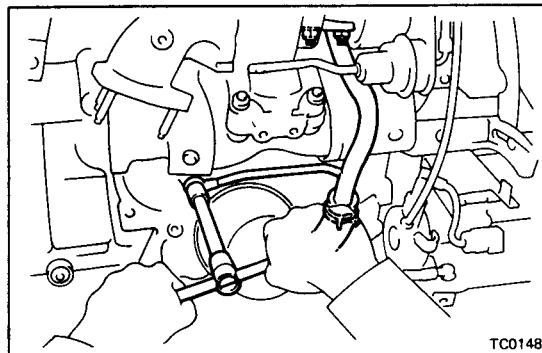

6. REMOVE TURBO OIL PIPE
 - (a) Remove the union bolt and two gaskets holding the turbo oil pipe to the cylinder block.
 - (b) Disconnect the turbo oil hose.
 - (c) Remove the two nuts, turbo oil pipe and gasket.

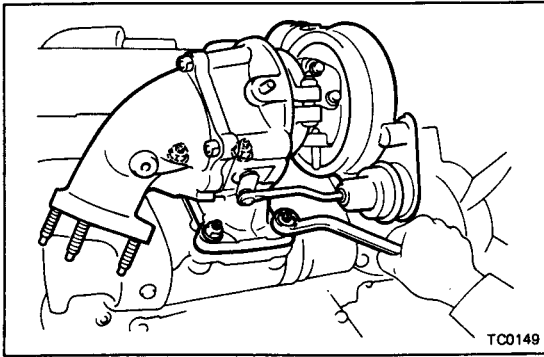

7. REMOVE TURBOCHARGER FROM EXHAUST MANIFOLD

Remove the four nuts, turbocharger and gasket.

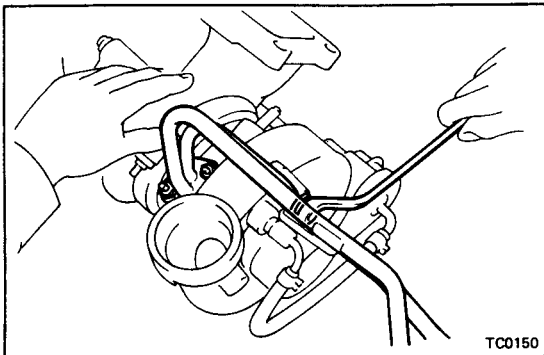

8. REMOVE TURBO WATER PIPE

Remove the bolt and two nuts, turbo water pipe and gasket.

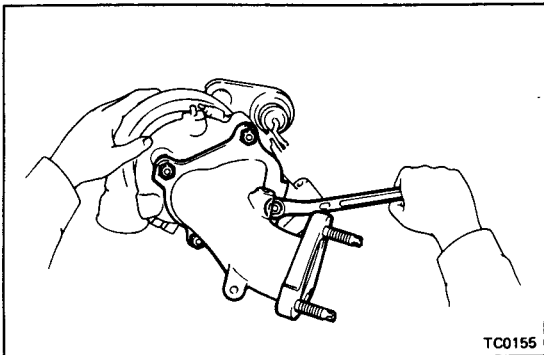

9. REMOVE TURBINE OUTLET ELBOW

Remove the four nuts, turbine outlet elbow and gasket.

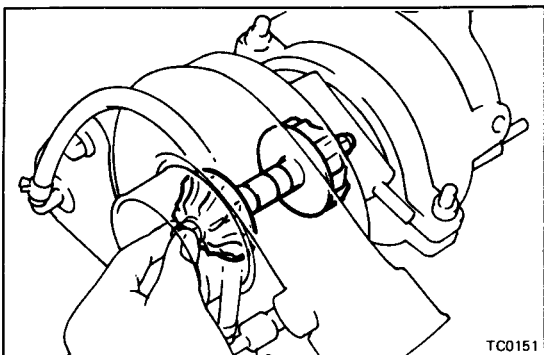

INSPECTION OF TURBOCHARGER

1. INSPECT IMPELLER WHEEL ROTATION

Grasp the edge of the turbine wheel and turn it. Check that the impeller wheel turns smoothly.

If the impeller wheel does not turn or if it turns with a drag, replace the turbocharger assembly.

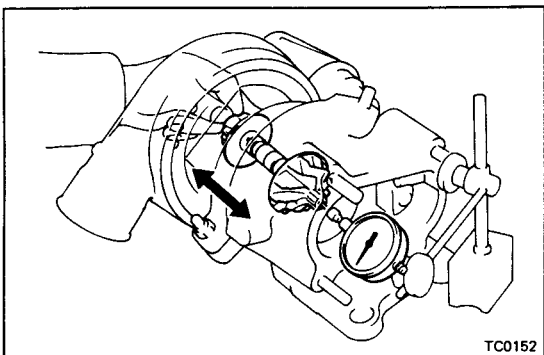

2. INSPECT AXIAL PLAY OF IMPELLER WHEEL

Insert a dial indicator into the intake side, hold the turbine wheel edge by hand and check the axial play.

Axial play: 0.13 mm (0.0051 in.) or less

If the axial play is not as specified, replace the turbocharger assembly.

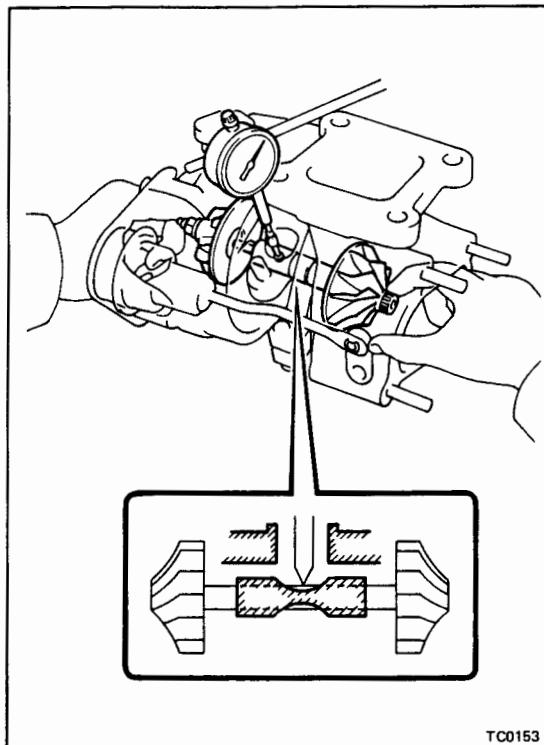

TC0153

3. INSPECT RADIAL PLAY OF TURBINE SHAFT

- (a) From the oil outlet hole, insert the dial indicator through the hole in the spacer bearing and set it in the center of the turbine shaft.
- (b) Moving the turbine shaft in a radial direction, measure the radial play of the shaft.

Radial play: 0.18 mm (0.0071 in.) or less

If the radial play is not as specified, replace the turbocharger assembly.

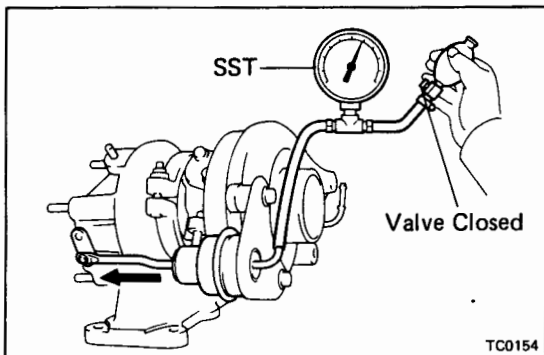

TC0154

4. INSPECT ACTUATOR OPERATION

- (a) Disconnect the actuator hose.
- (b) Using SST (turbocharger pressure gauge), apply approx. 0.81 kg/cm² (11.5 psi, 79 kPa) of pressure to the actuator and check that the rod moves.

SST 09992-00241

If the rod does not move, replace the turbocharger assembly.

NOTICE: Never apply more than 0.95 kg/cm² (13.5 psi, 94 kPa) of pressure to the actuator.

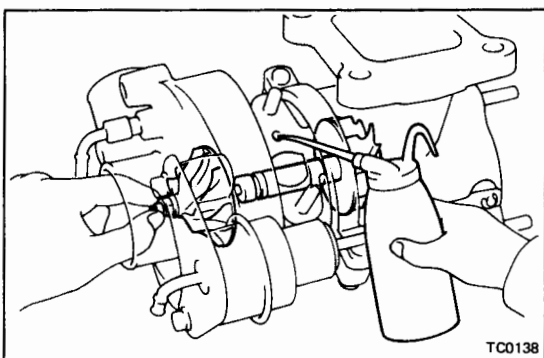

TC0138

INSTALLATION OF TURBOCHARGER

(See page TC-9)

NOTICE: After replacing the turbocharger assembly, pour approx. 20 cc (1.2 cu in.) of new oil into the oil inlet and turn the impeller wheel by hand to splash oil on the bearing.

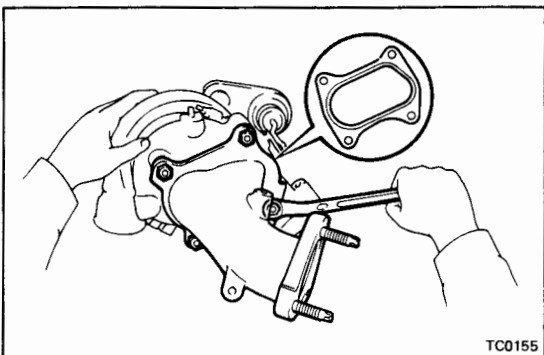

TC0155

1. INSTALL TURBINE OUTLET ELBOW

Install a new gasket and the turbine outlet elbow with the four nuts.

Torque: 260 kg-cm (19 ft-lb, 25 N·m)

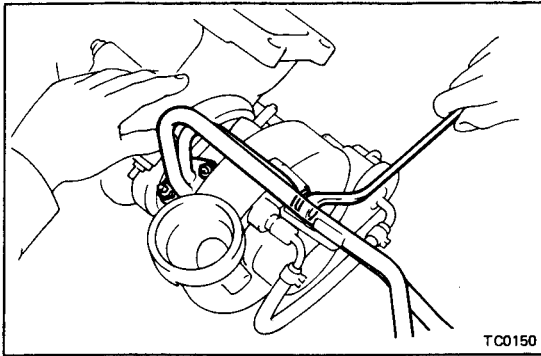

2. INSTALL TURBO WATER PIPE

Install a new gasket and the water pipe with the two nuts and bolt.

Torque: 80 kg-cm (69 in.-lb, 7.8 N-m)

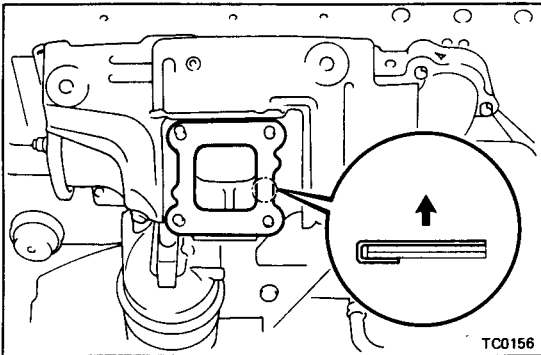

3. INSTALL TURBOCHARGER TO EXHAUST MANIFOLD

(a) Install a new gasket to the exhaust manifold.

(b) Install the turbocharger with the four nuts.

Torque: 530 kg-cm (38 ft-lb, 52 N-m)

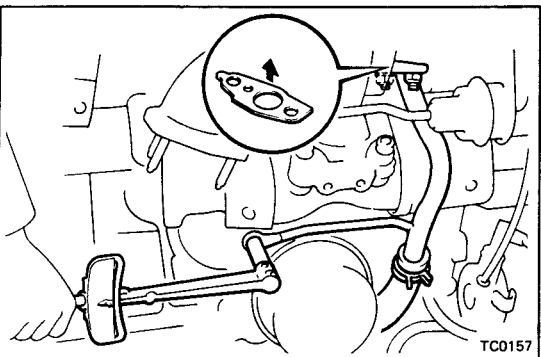
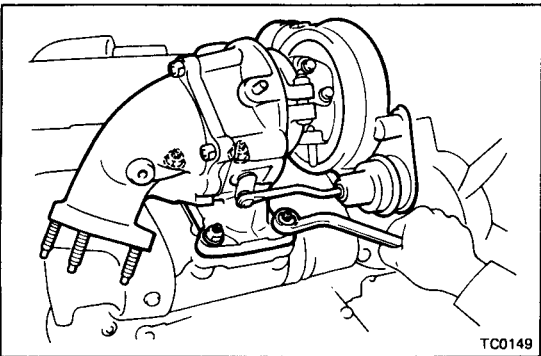

4. INSTALL TURBO OIL PIPE

(a) Install a new gasket and the turbo oil pipe with the two nuts.

Torque: 195 kg-cm (14 ft-lb, 19 N-m)

(b) Connect the turbo oil hose.

(c) Install two new gaskets and the union bolt of the turbo oil pipe.

Torque: 260 kg-cm (19 ft-lb, 25 N-m)

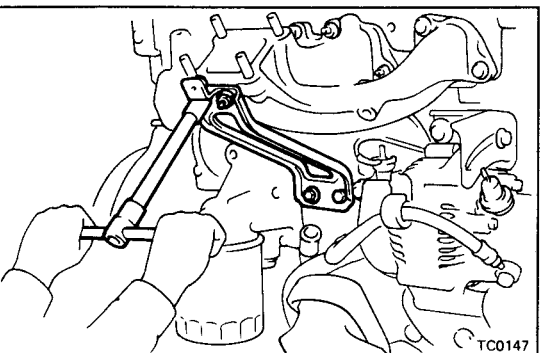

5. INSTALL EXHAUST MANIFOLD STAY

Install the exhaust manifold stay with the two bolts and two nuts.

Torque: 195 kg-cm (14 ft-lb, 19 N-m)

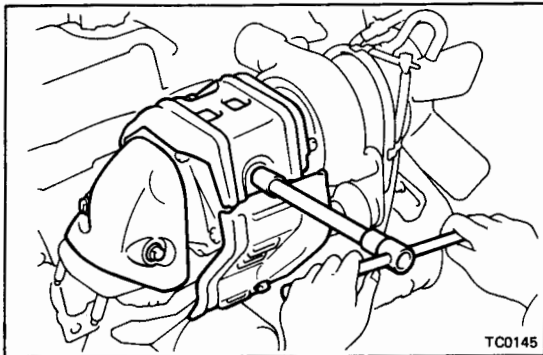
**6. INSTALL TURBOCHARGER HEAT INSULATOR**

Install the three heat insulators with the four bolts.

Torque: 120 kg-cm (9 ft-lb, 12 N·m)

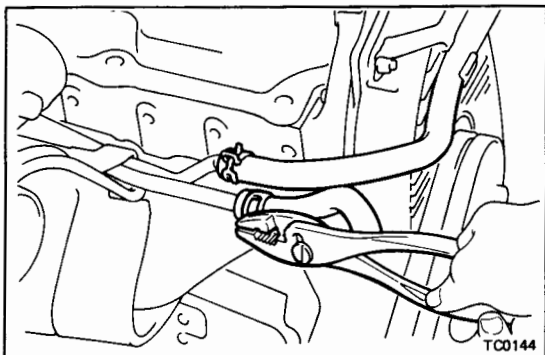
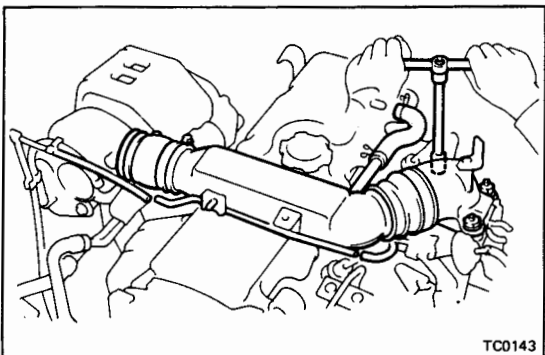
**7. CONNECT WATER BY-PASS HOSES****8. INSTALL INTAKE PIPE**

(a) Connect the air hose and install a new gasket and the intake pipe with the three nuts.

Torque: 120 kg-cm (9 ft-lb, 12 N·m)

(b) Connect boost compensator vacuum hoses.

9. FILL ENGINE WITH COOLANT (See page CO-5)**10. START ENGINE AND CHECK FOR LEAKS****11. CHECK ENGINE OIL LEVEL**

FUEL SYSTEM

REFER TO 2L, 3L ENGINE REPAIR MANUAL
(Pub. No. RM123E)

NOTE: The following pages contain only the points which differ from the above listed manual.

	Page
FUEL HEATER SYSTEM (LJ)	FU-2
INJECTION PUMP	FU-3

FU

FUEL HEATER SYSTEM (LJ) SYSTEM CIRCUIT

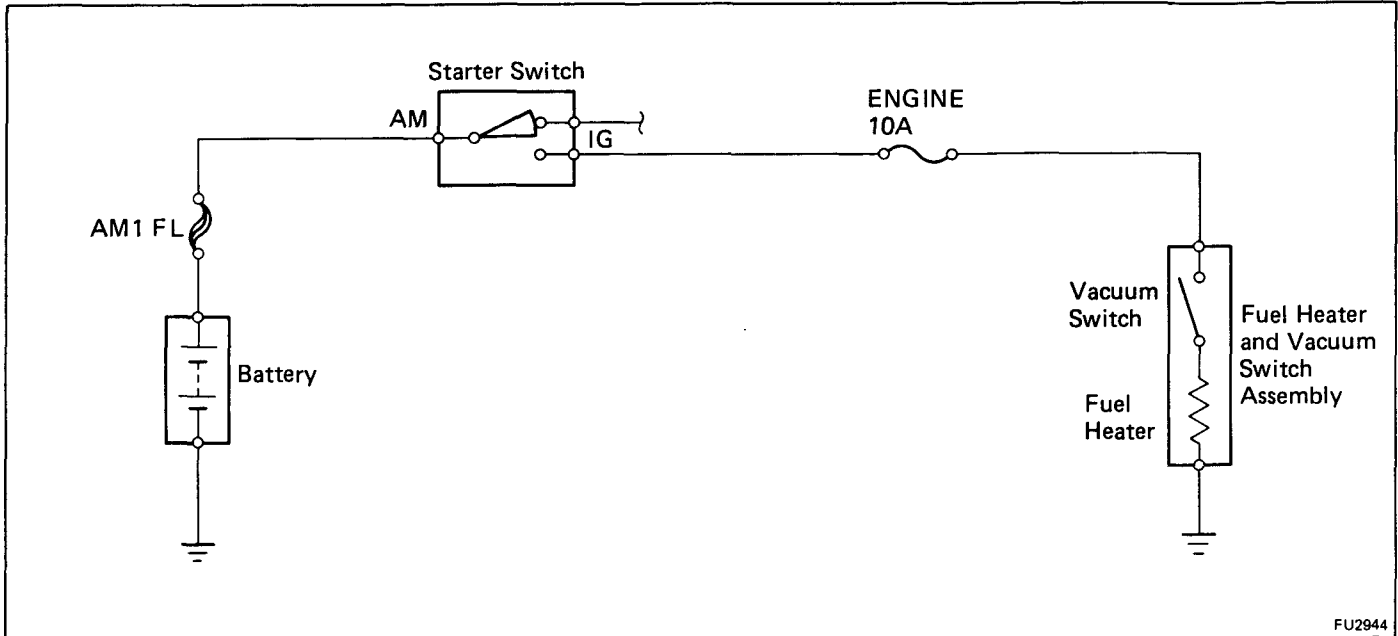

FU2944

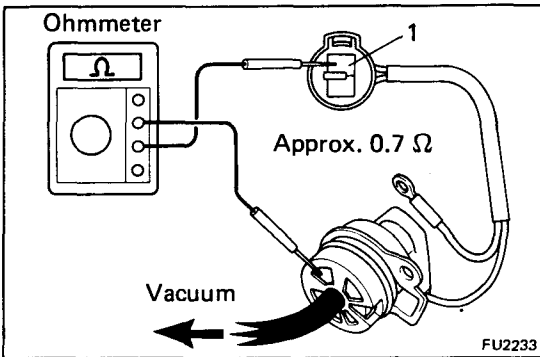

INSPECTION OF COMPONENTS

Fuel Heater

INSPECT FUEL HEATER

- (a) Apply a vacuum of 285 ± 50 mmHg (11.22 ± 1.97 in.Hg, 38.0 ± 6.7 kPa) or more to the vacuum switch port.
- (b) Using an ohmmeter, measure the resistance between terminal 1 and the switch body.

Resistance: Approx. 0.7Ω at 20°C (68°F)

If the resistance is not as specified, replace the fuel heater and vacuum switch assembly.

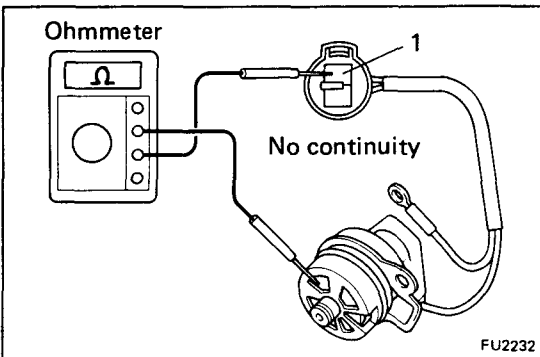

Vacuum Switch

1. INSPECT SWITCH CONTINUITY

Using an ohmmeter, check that there is no continuity between terminal 1 and the switch body.

If continuity is not as specified, replace the fuel heater and vacuum switch assembly.

2. INSPECT SWITCH OPERATION

- (a) Apply a vacuum of 285 ± 50 mmHg (11.22 ± 1.97 in.Hg, 38.0 ± 6.7 kPa) or more to the vacuum switch port.
- (b) Using an ohmmeter, check that there is continuity between terminal 1 and the switch body.

If operation is not as specified, replace the fuel heater and vacuum switch assembly.

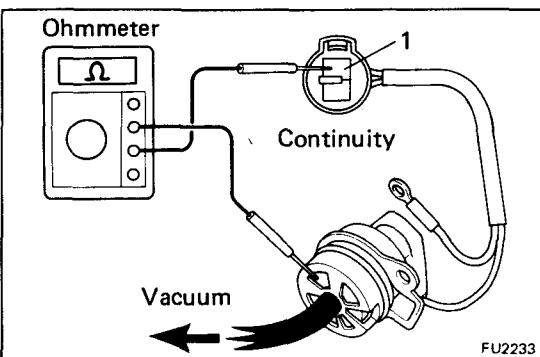

INJECTION PUMP

REMOVAL OF INJECTION PUMP

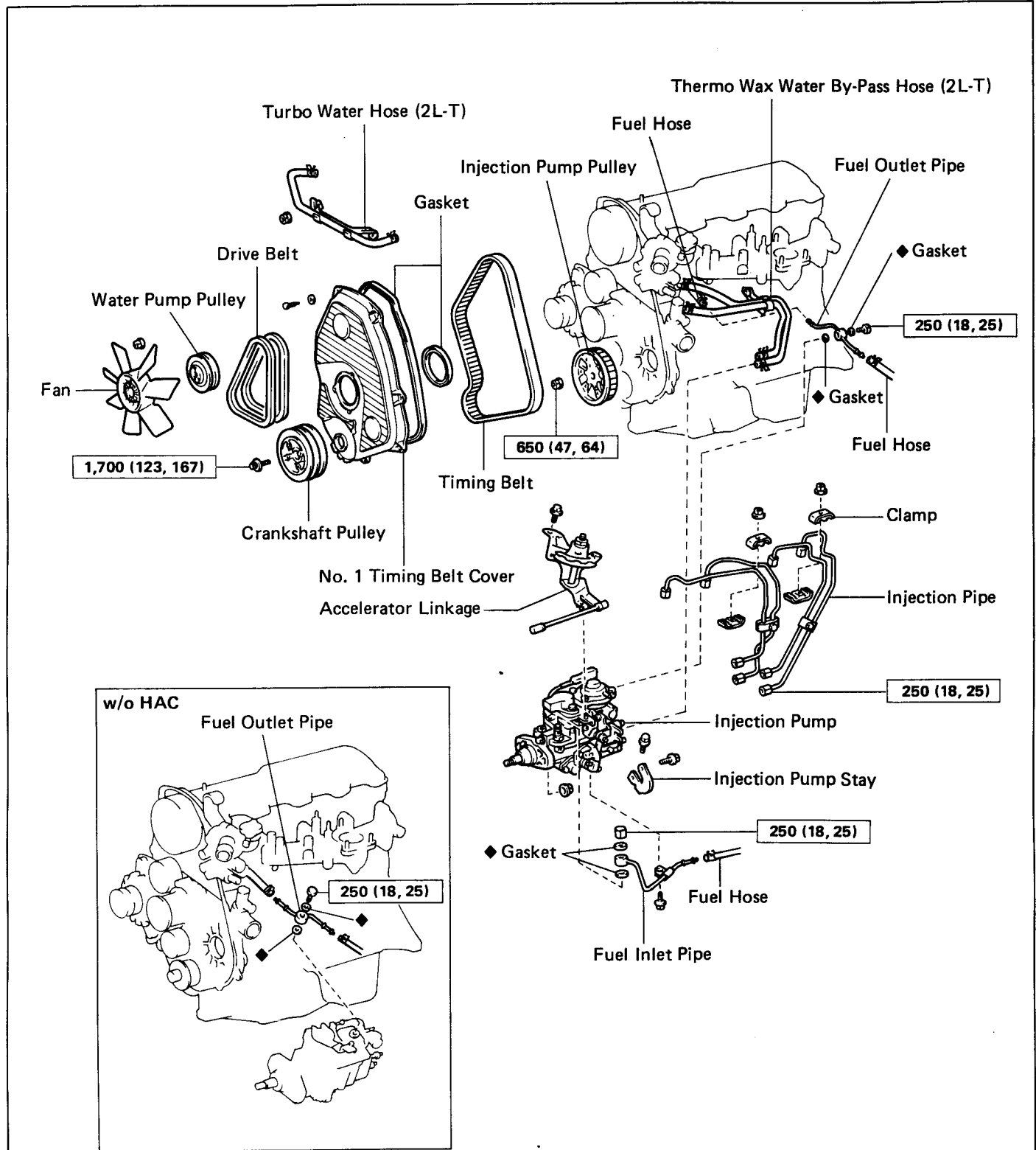

kg-cm (ft-lb, N-m) : Specified torque

◆ Non-reusable part

1. (2L-T)
DRAIN ENGINE COOLANT (See page CO-4)
2. (2L-T)
REMOVE TURBO WATER HOSE
3. REMOVE DRIVE BELTS, FAN AND WATER PUMP PULLEY
4. REMOVE CRANKSHAFT PULLEY
5. REMOVE NO. 1 TIMING BELT COVER
6. SET NO. 1 CYLINDER TO TDC/COMPRESSION
7. REMOVE TIMING BELT
8. REMOVE INJECTION PUMP DRIVE PULLEY
9. REMOVE ACCELERATOR LINKAGE
10. (2L-T)
DISCONNECT BOOST COMPENSATOR HOSE
11. (w/ A/C)
DISCONNECT A/C IDLE-UP VACUUM HOSE
12. (2L-T)
DISCONNECT WATER BY-PASS HOSES FROM THERMO WAX
13. DISCONNECT INJECTION PUMP CONNECTOR(S)
14. DISCONNECT FUEL HOSES FROM INJECTION PUMP

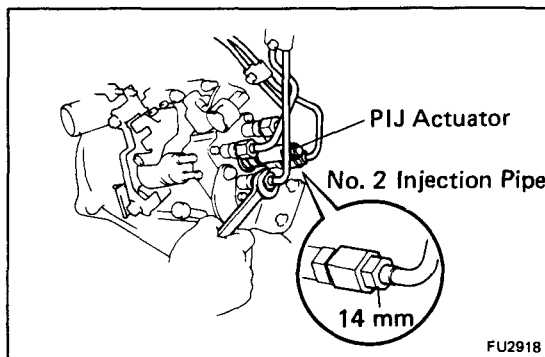

15. REMOVE INJECTION PIPES

- (a) Loosen the union nuts of the injection pipes from the injection nozzles.
- (b) Loosen the union nuts of the injection pipes from the injection pump.
- (c) Remove the four clamps and injection pipes.

NOTICE: On vehicles with PIJ (2L-T Austria), do not interfere with the PIJ actuator with the spanner. Use a 14 mm spanner when loosening the union nut of the No. 2 injection pipe.

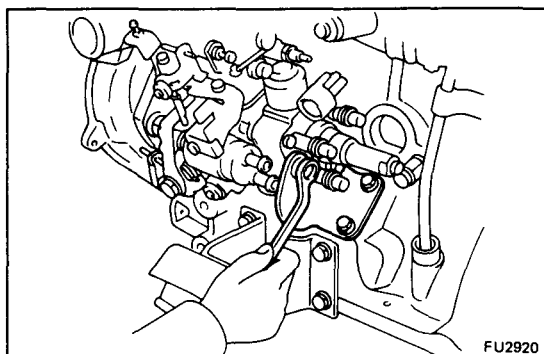

16. REMOVE INJECTION PUMP

- (a) Remove the four bolts and pump stay.

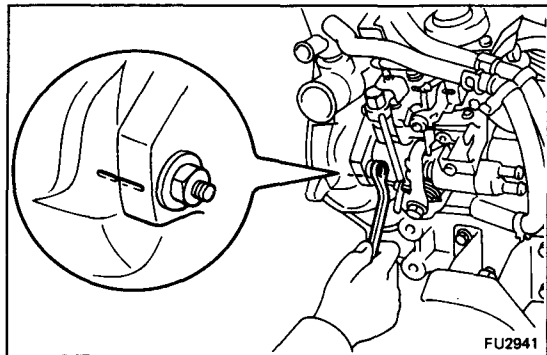

(b) Before removing the injection pump, check if the period lines are aligned.

If not, place new matchmarks for reinstallation.

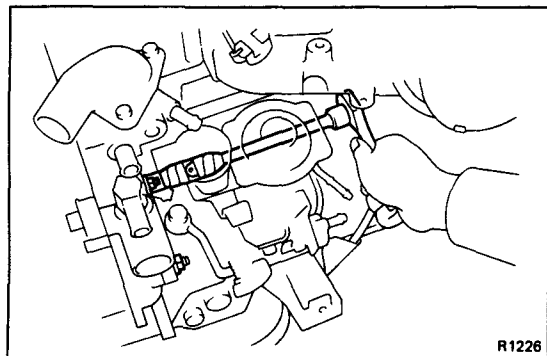

(c) Remove the two nuts and injection pump.

NOTICE:

- Do not hold or carry the injection pump by the adjusting lever.
- Do not put the injection pump (2L-T and w/ HAC) at an angle more than 45° from the horizontal.

17. REMOVE FUEL INLET AND OUTLET PIPES FROM INJECTION PUMP

COMPONENTS

2L-T

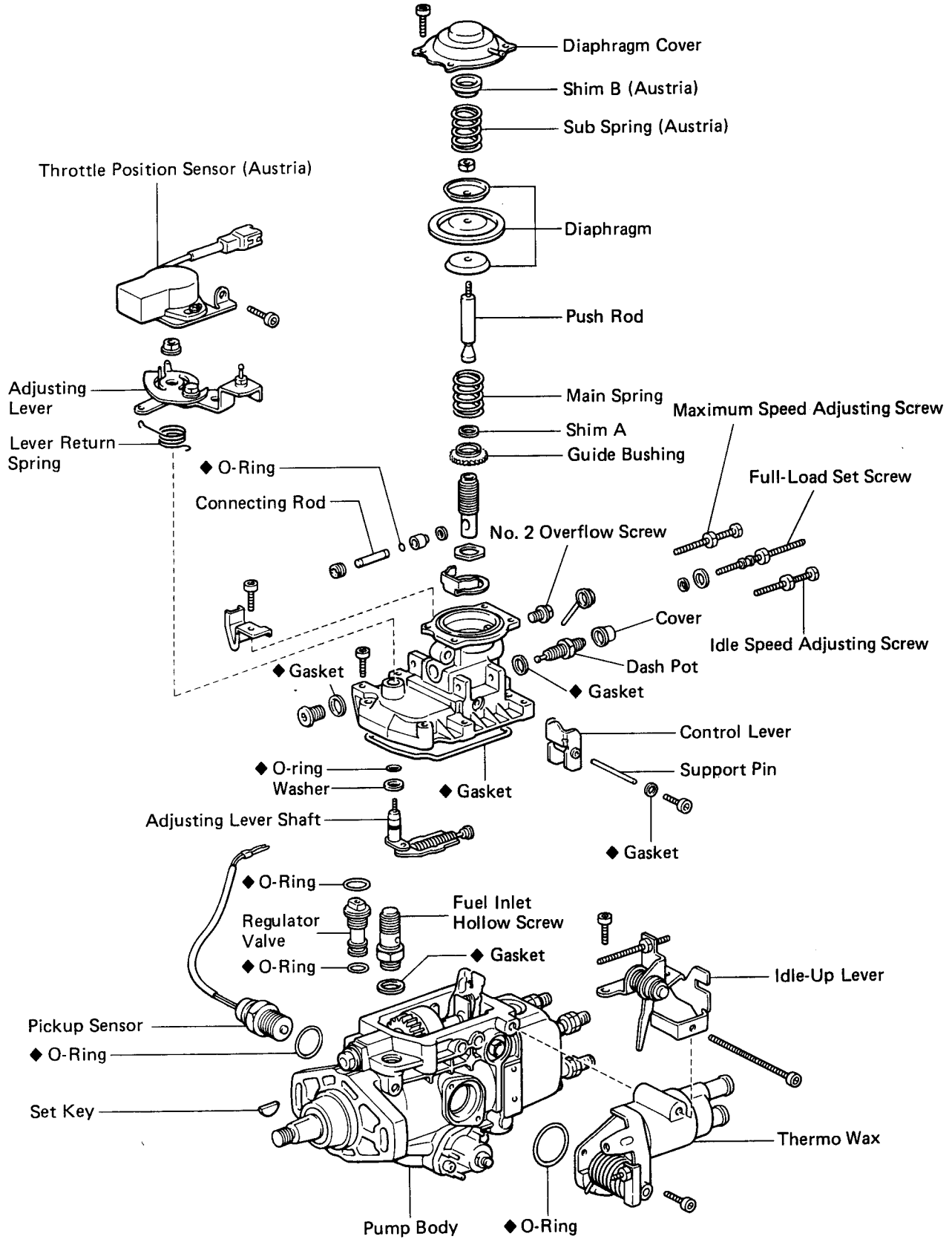

◆ Non-reusable part

COMPONENTS (Cont'd)

3L

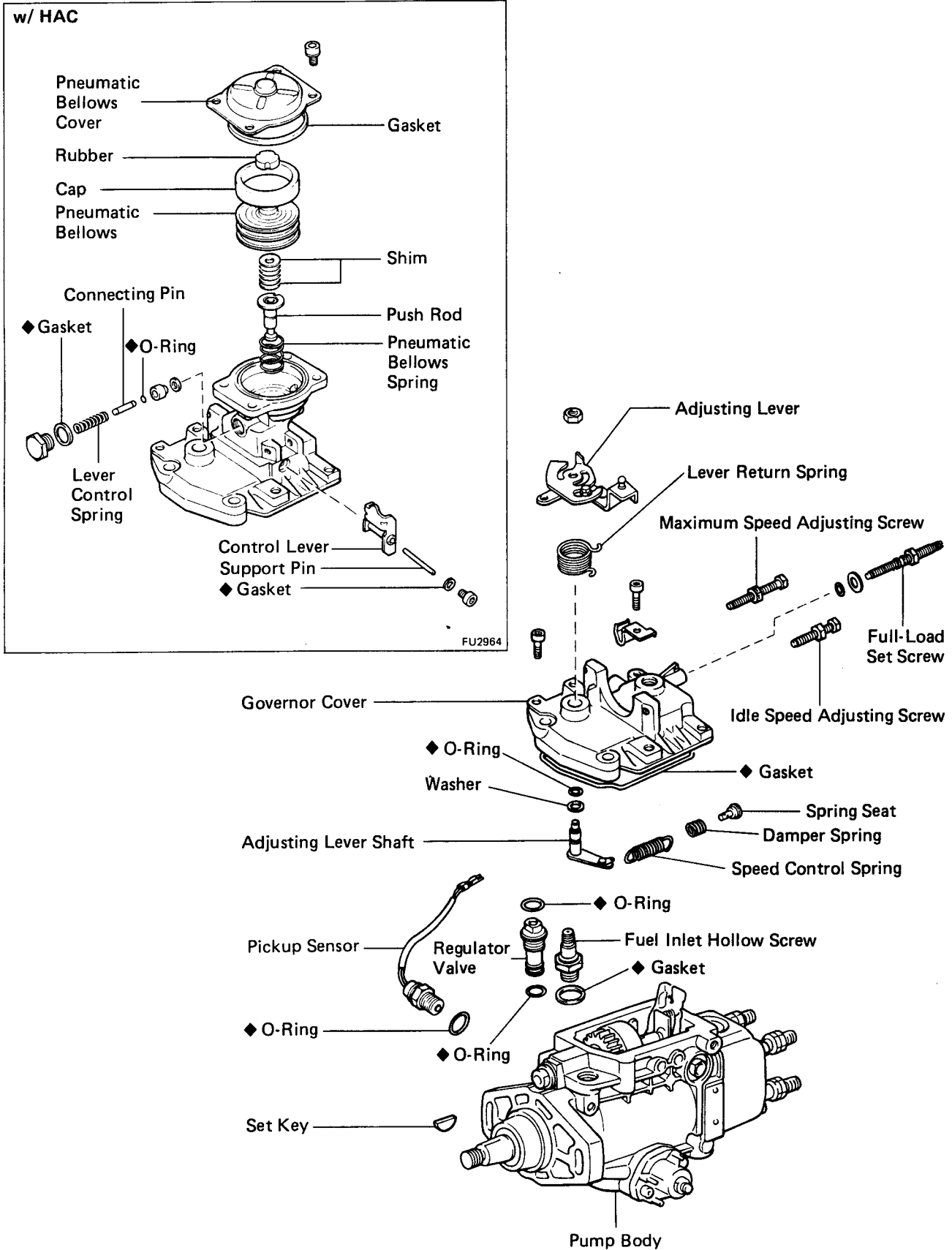

◆ Non-reusable part

FU2922

COMPONENTS (Cont'd)

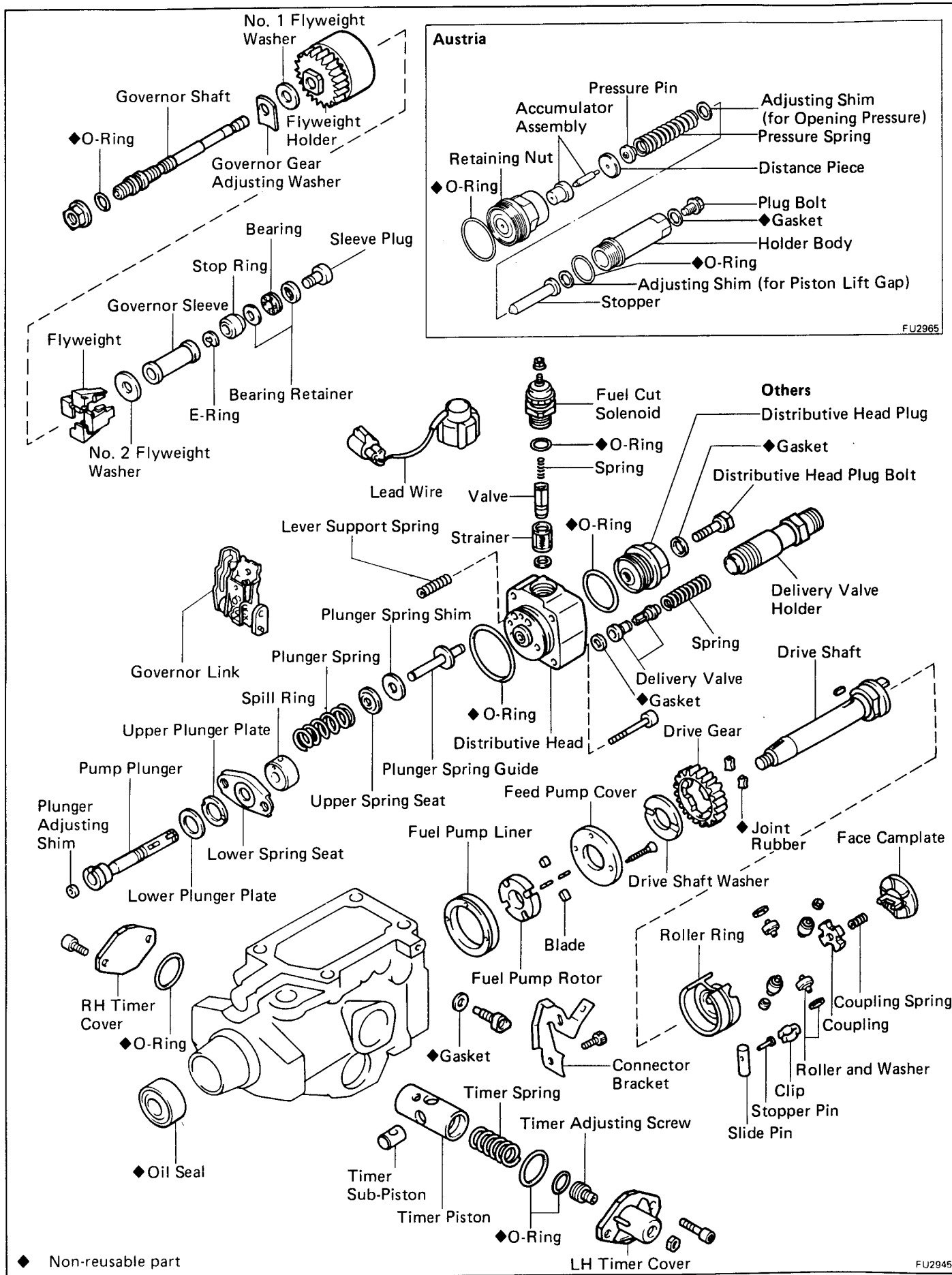

FU2965

FU2945

◆ Non-reusable part

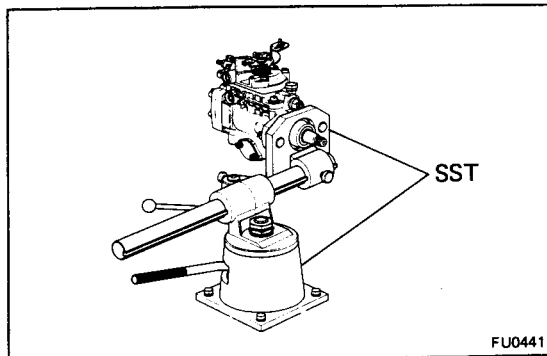

DISASSEMBLY OF INJECTION PUMP

(See pages FU-6 to 8)

1. MOUNT PUMP ASSEMBLY TO SST (STAND)
SST 09241-76022 and 09245-54010
2. REMOVE SET KEY OF DRIVE PULLEY FROM DRIVE SHAFT
3. (w/ A/C)
REMOVE IDLE-UP ACTUATOR

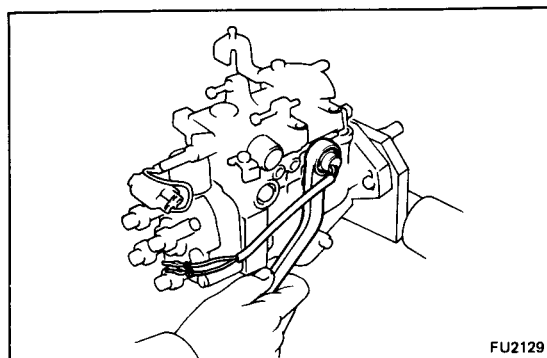

4. (w/ Tachometer)
REMOVE PICKUP SENSOR
 - (a) Disconnect the lead wires from the connector.
 - (b) Remove the pickup sensor and O-ring.

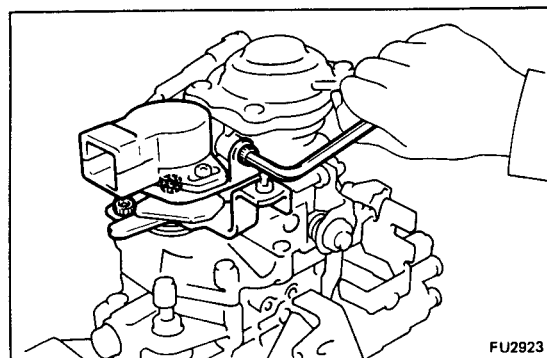

5. (2L-T Austria)
REMOVE THROTTLE POSITION SENSOR
Using a 5 mm hexagonal wrench, remove the three bolts and throttle position sensor.

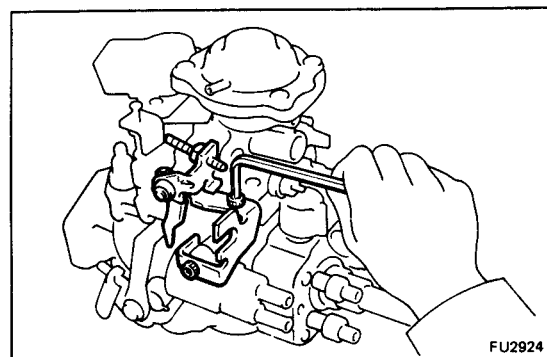

6. (2L-T)
REMOVE IDLE-UP LEVER
Using a 5 mm hexagonal wrench, remove the three bolts and idle-up lever.

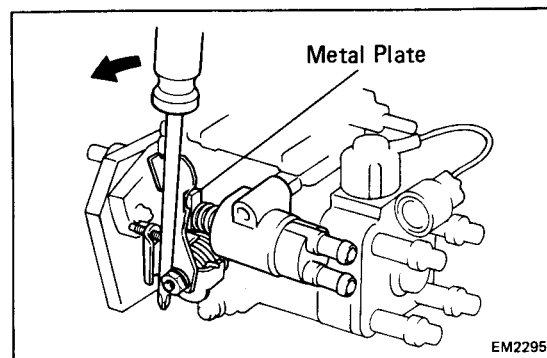

7. (2L-T)
REMOVE THERMO WAX
 - (a) Using a screwdriver, turn the cold starting lever counterclockwise approx. 20°.
 - (b) Put a metal plate (thickness of 8.5 – 10 mm (0.335 – 0.394 in.)) between the cold starting lever and thermo wax plunger.

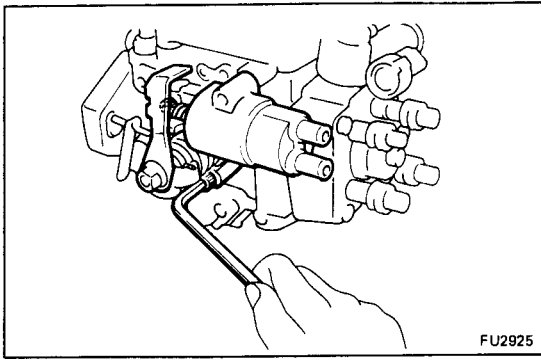

- (c) Using a 5 mm hexagonal wrench, remove the two bolts, thermo wax and O-ring.

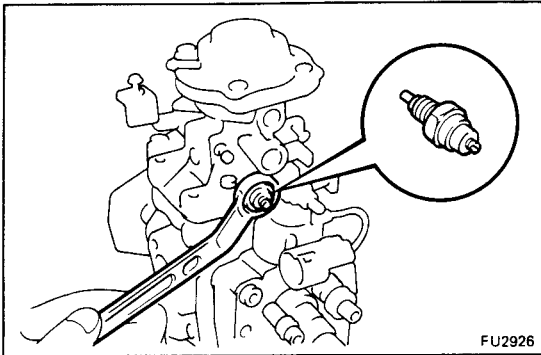

8. (2L-T)
REMOVE DASH POT
Remove the dash pot and gasket.

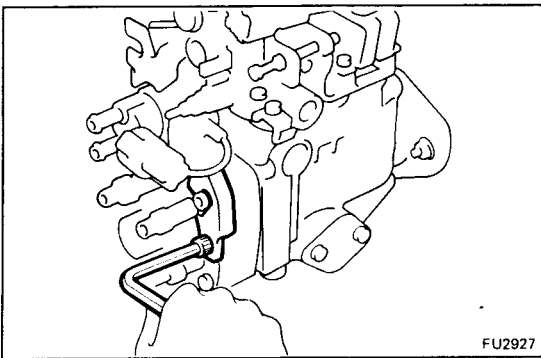

9. **REMOVE FUEL CUT SOLENOID**
- Using a 6 mm hexagonal wrench, remove the bolt and connector bracket.
 - Disconnect the lead wire connector from the bracket.
 - Disconnect the dust cover from the fuel cut solenoid.
 - Remove the nut, lead wire and dust cover.

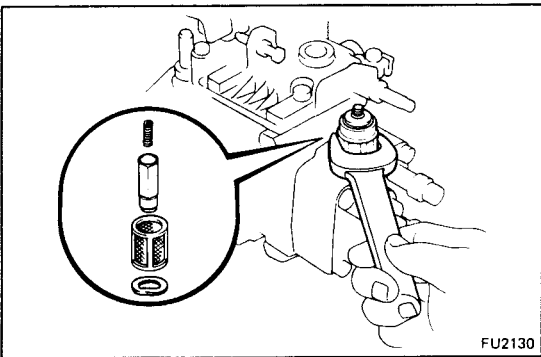

- (e) Remove the fuel cut solenoid, O-ring, spring, valve, strainer and wave washer.

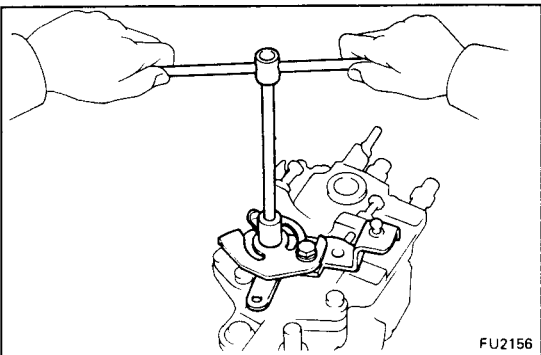

10. **REMOVE ADJUSTING LEVER**
Remove the bolt, nut, adjusting lever and return spring.

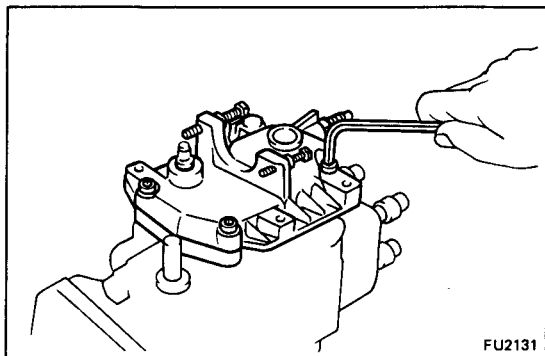

11. REMOVE GOVERNOR COVER

- (a) (2L-T and w/ HAC)
Remove the idle speed adjusting screw.
- (b) Using a 5 mm hexagonal wrench, remove the four bolts.

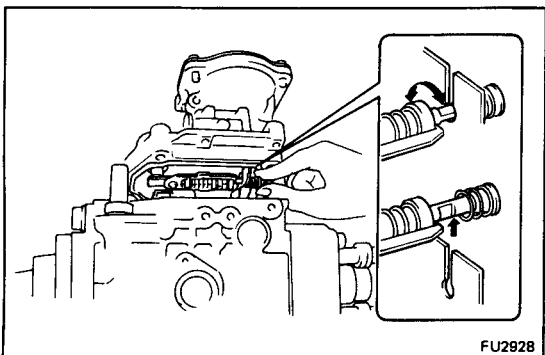

- (c) (2L-T)
Disconnect the adjusting shaft assembly from the governor link and remove the governor cover and gasket.

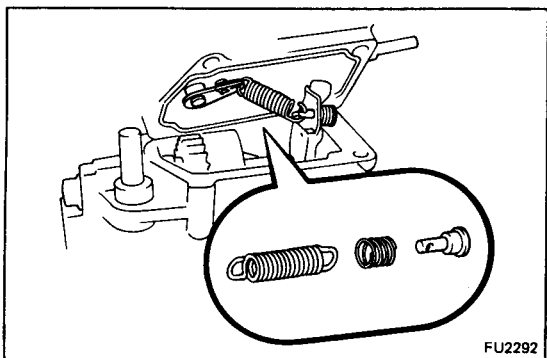

- (d) (3L)
Disconnect the speed control spring from the spring seat, and remove the spring seat, damper spring, speed control spring, governor cover, adjusting lever shaft assembly and gasket.

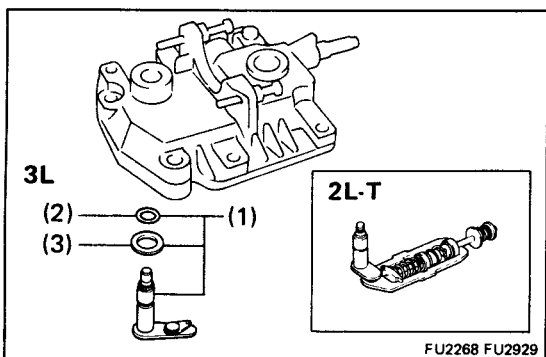

12. REMOVE GOVERNOR ADJUSTING LEVER SHAFT FROM GOVERNOR COVER

Remove the following parts from the governor cover.

- (1) Adjusting lever shaft, O-ring and washer assembly
- (2) O-ring
- (3) Washer

13. (2L-T) DISASSEMBLE BOOST COMPENSATOR

A. Remove boost compensator diaphragm

- (a) Using a 5 mm hexagonal wrench, remove the four bolts, and diaphragm cover.

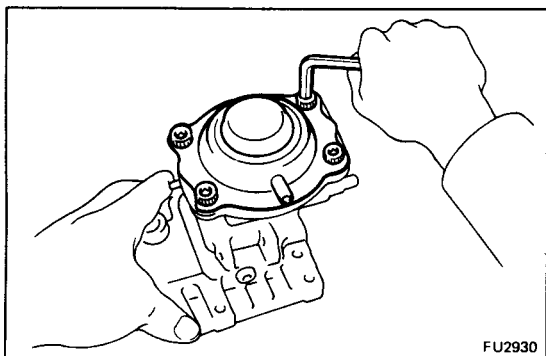

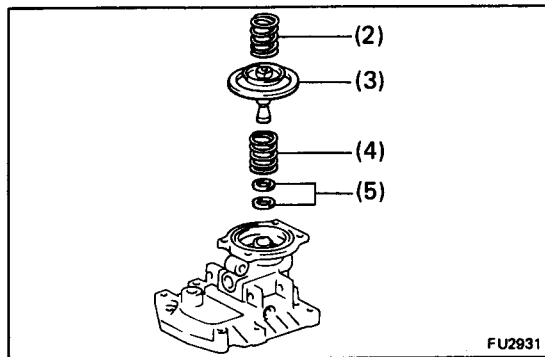

- (b) Place the matchmarks on the diaphragm and governor cover.
- (c) Remove the following parts:
 - (1) Boost compensator shim B (Austria only)
 - (2) Sub spring (Austria only)
 - (3) Diaphragm and push rod
 - (4) Main spring
 - (5) Boost compensator shim A

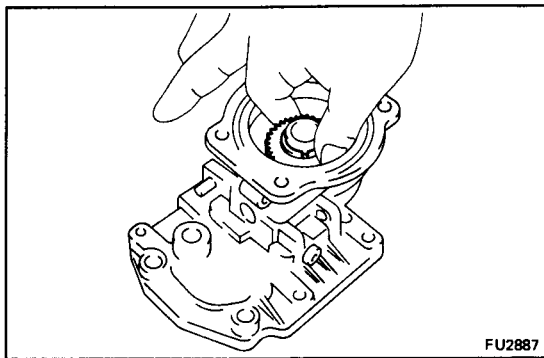

B. Remove guide bushing

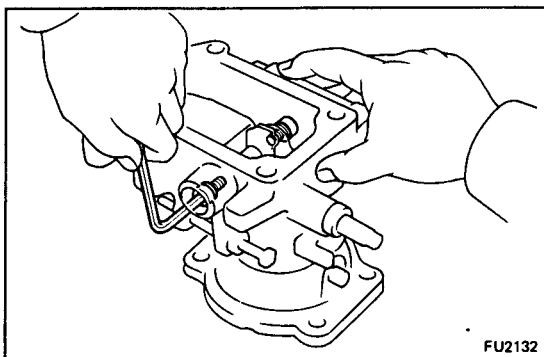

C. Remove control lever

- (a) Using a 4 mm hexagonal wrench, remove the two bolts and gaskets.

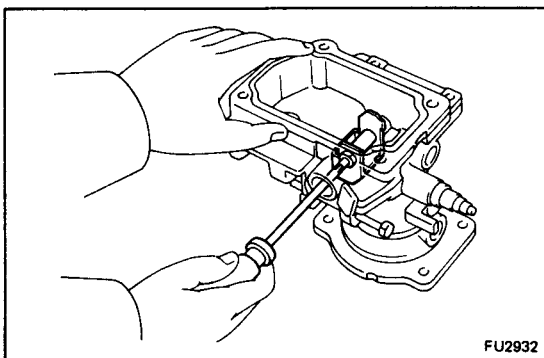

- (b) Using a small screwdriver, push out the support pin and remove the control lever.

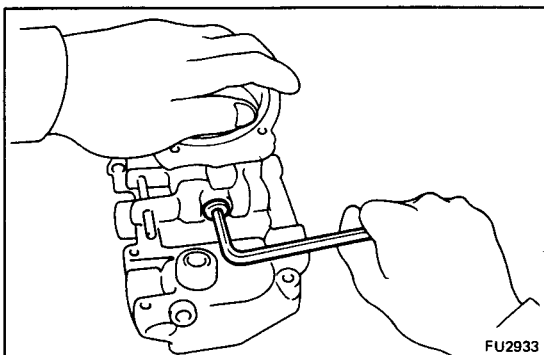

- (c) Using a 4 mm hexagonal wrench, remove the plug and gasket.

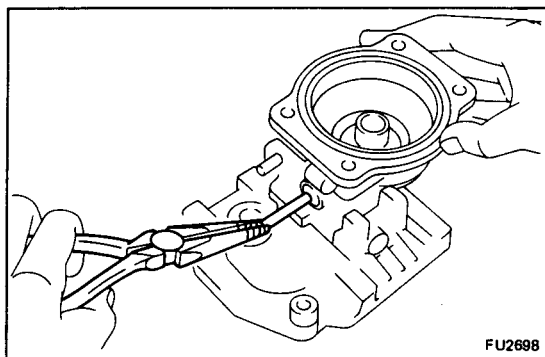

(d) Using needle nose pliers, remove the connecting pin.
NOTICE: Be careful not to damage the connecting pin.
 Tape the tip of the pliers.

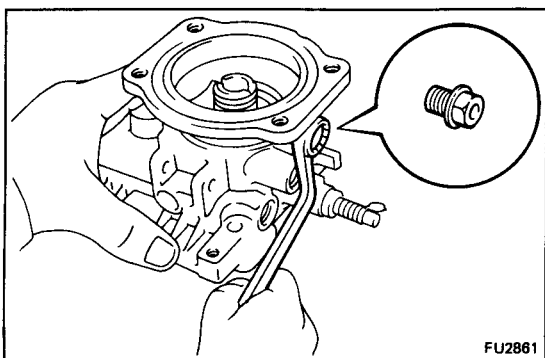

D. Remove No. 2 overflow screw
 Remove the cover and No. 2 overflow screw.

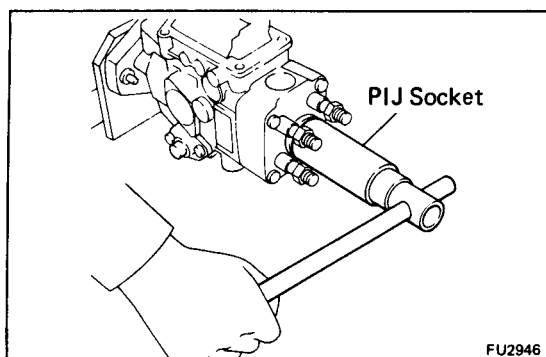

14. (2L-T Austria)
REMOVE PILOT INJECTION (PIJ) ACTUATOR
 Using the PIJ socket, remove the PIJ actuator.
 Part No. 95096-10380 (NIPPONDENSO)

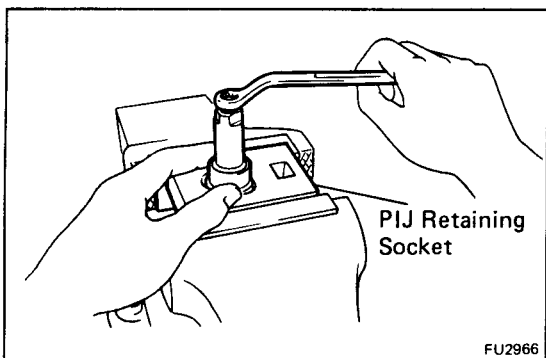

15. (2L-T Austria)
PIJ INJECTION PRESSURE TEST
 (a) Using the PIJ retaining socket, remove the plug bolt and gasket.
 Part No. 95096-10390 (NIPPONDENSO)

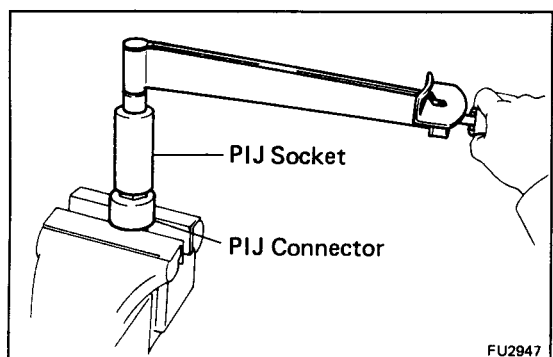

(b) Using the PIJ socket, install the PIJ actuator on the PIJ connector, and torque.
 Part No. 95096-10380 and 95096-10400 (NIPPONDENSO)
Torque: 675 kg-cm (49 ft-lb, 66 N-m)

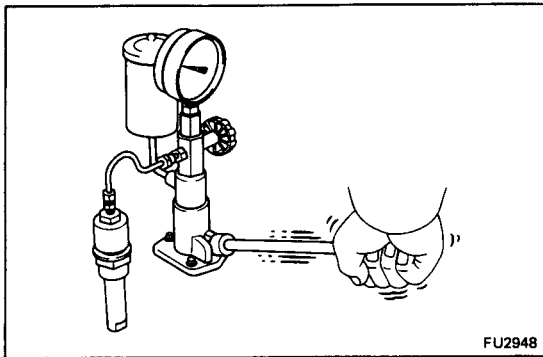

(c) Install the PIJ actuator to the injection hand tester and pump the tester handle a few times.

HINT: After the PIJ valve opens (making a clicking sound as the pressure is raised), wait until injection occurs (the pressure gradually decreases and stops at a certain pressure), then raise the pressure again.

(d) Pump the tester handle slowly and observe the pressure gauge.

HINT: Increase the pressure at a steady pace so that the PIJ opens at the end of one stroke.

(e) Read the pressure gauge just as the injection pressure begins to drop.

**Opening pressure: 123 – 127 kg/cm²
(1,749 – 1,806 psi)
(12,054 – 12,446 kPa)**

If the opening pressure is not as specified, disassemble the PIJ actuator and change the adjusting shim on the top of the pressure spring.

Adjusting shim thickness					mm (in.)
0.500 (0.0197)	1.025 (0.0404)	1.300 (0.0512)	1.575 (0.0620)	1.850 (0.0728)	2.250 (0.0886)
0.550 (0.0217)	1.050 (0.0413)	1.325 (0.0522)	1.600 (0.0630)	1.875 (0.0738)	2.300 (0.0906)
0.600 (0.0236)	1.075 (0.0423)	1.350 (0.0531)	1.625 (0.0640)	1.900 (0.0748)	2.350 (0.0925)
0.650 (0.0256)	1.100 (0.0433)	1.375 (0.0541)	1.650 (0.0650)	1.925 (0.0758)	2.400 (0.0945)
0.700 (0.0276)	1.125 (0.0443)	1.400 (0.0551)	1.675 (0.0659)	1.950 (0.0768)	2.450 (0.0965)
0.750 (0.0295)	1.150 (0.0453)	1.425 (0.0561)	1.700 (0.0669)	1.975 (0.0778)	2.500 (0.0984)
0.800 (0.0315)	1.175 (0.0463)	1.450 (0.0571)	1.725 (0.0679)	2.000 (0.0787)	
0.850 (0.0335)	1.200 (0.0472)	1.475 (0.0581)	1.750 (0.0689)	2.050 (0.0807)	
0.900 (0.0354)	1.225 (0.0482)	1.500 (0.0591)	1.775 (0.0699)	2.100 (0.0827)	
0.950 (0.0374)	1.250 (0.0492)	1.525 (0.0600)	1.800 (0.0709)	2.150 (0.0846)	
1.000 (0.0394)	1.275 (0.0502)	1.550 (0.0610)	1.825 (0.0719)	2.200 (0.0866)	

HINT:

- Varying the adjusting shim thickness by 0.025 mm (0.0010 in.) changes the injection pressure by about 2.7 kg/cm² (38.4 psi, 245 kPa).
- For the second measurement or more, wait until the PIJ has injected first (the pressure drops to a certain level).

**16. (2L-T Austria)
DISASSEMBLE PILOT INJECTION (PIJ) ACTUATOR**

(a) Using the PIJ body socket and PIJ retaining socket, remove the retaining nut.

Part No. 95096-10390 and 95096-10400 (NIPPONDENSO)

NOTICE: Do not drop the accumulator.

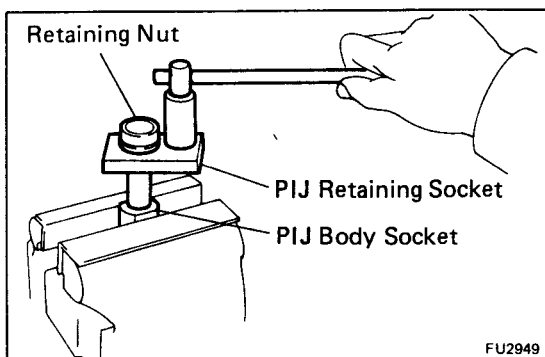

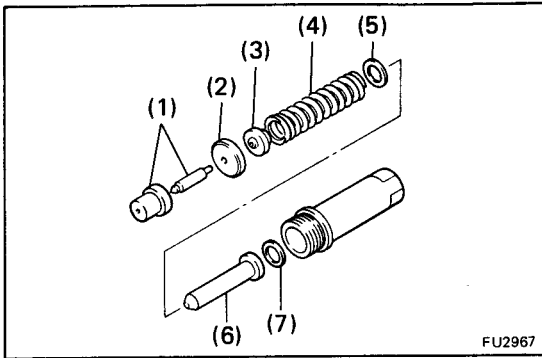

(b) Remove the following parts from the holder body.

- (1) Accumulator assembly
- (2) Distance piece
- (3) Pressure pin
- (4) Pressure spring
- (5) Adjusting shim (for opening pressure)
- (6) Stopper
- (7) Adjusting shim (for piston lift gap)

HINT: The shims in (5) and (7) are the same shape so keep them separate to distinguish between them.

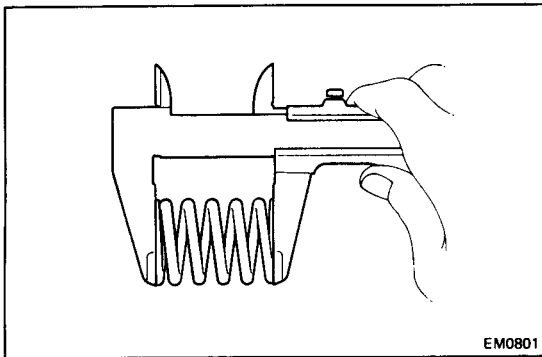

INSPECTION OF INJECTION PUMP COMPONENTS

1. INSPECT SPRING LENGTH

Using vernier calipers, measure the free length of each spring.

Spring free length:

Delivery valve spring	24.4 mm (0.961 in.)
Plunger spring	30.0 mm (1.181 in.)
Coupling spring	16.0 mm (0.630 in.)
Pneumatic bellows spring (w/ HAC)	35.0 mm (1.378 in.)

Boost compensator main spring

2L-T (Austria) 24.1 mm (0.949 in.)

2L-T (Others) 19.4 mm (0.764 in.)

Boost compensator sub spring (2L-T Austria)

22.3 mm (0.878 in.)

If the free length is not as specified, replace the spring(s).

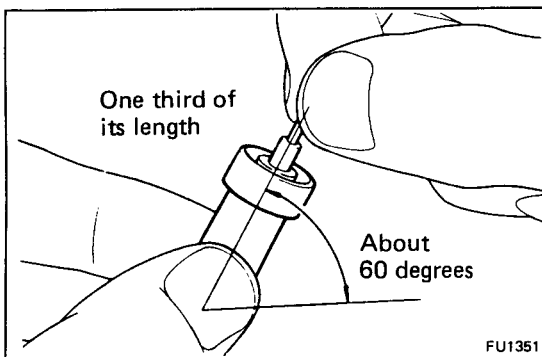

2. (2L-T Austria) INSPECT ACCUMULATOR ASSEMBLY

(a) Wash the accumulator in clean diesel oil.

NOTICE: Do not touch the accumulator mating surfaces with your fingers.

(b) Tilt the accumulator guide about 60 degrees and pull the piston out about one third of its length.

(c) When released, the piston should sink down into the guide vent smoothly by its own weight.

(d) Repeat this test, rotating the piston slightly each time.

If the piston does not sink freely, replace the accumulator assembly.

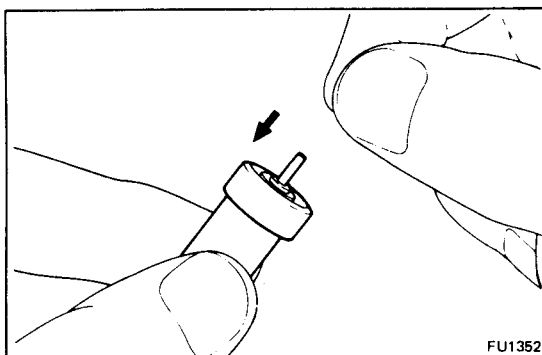

ASSEMBLY OF INJECTION PUMP

(See pages FU-6 to 8)

1. ADJUST PLUNGER SPRING SHIM

(a) Install the following parts to the distributive head:

- (1) Two plunger spring guides
- (2) Two upper spring seats
- (3) Two plunger springs
- (4) Lower spring seat
- (5) Upper plunger plate
- (6) Lower plunger plate
- (7) Pump plunger

HINT: Do not assemble the plunger spring shims at this time.

(b) Using vernier calipers, measure clearance A indicated in the illustration.

(c) Determine the plunger spring shim size by using the following formula and chart.

2L-T (Austria)

$$\text{New plunger spring shim thickness} = 6.1 - A$$

2L-T (Others) and 3L

$$\text{New plunger spring shim thickness} = 5.9 - A$$

A ... Measured plunger position

Plunger spring shim selection chart for 2L-T (Austria)

mm (in.)

Measured clearance	Shim thickness	Measured clearance	Shim thickness
More than 4.6 (0.181)	1.5 (0.059)	3.6 – 3.8 (0.142 – 0.150)	2.5 (0.098)
4.3 – 4.5 (0.169 – 0.177)	1.8 (0.071)	3.3 – 3.5 (0.130 – 0.138)	2.8 (0.110)
4.1 – 4.2 (0.161 – 0.165)	2.0 (0.079)	Less than 3.2 (0.126)	3.0 (0.118)
3.9 – 4.0 (0.154 – 0.157)	2.2 (0.087)	–	–

Plunger spring shim selection chart for 2L-T (Others) and 3L

mm (in.)

Measured clearance	Shim thickness	Measured clearance	Shim thickness
More than 5.3 (0.209)	0.5 (0.020)	4.3 – 4.5 (0.169 – 0.177)	1.5 (0.059)
5.0 – 5.2 (0.196 – 0.205)	0.8 (0.031)	4.0 – 4.2 (0.157 – 0.165)	1.8 (0.071)
4.8 – 4.9 (0.189 – 1.193)	1.0 (0.039)	Less than 3.9 (0.154)	2.0 (0.079)
4.6 – 4.7 (0.181 – 0.185)	1.2 (0.047)	–	–

HINT:

- For a measurement between listed sizes, use the next larger size. Ex. If thickness is 1.1 mm (0.043 in.) by calculation, use a 1.2 mm (0.047 in.) shim.
- Select two shims which have the same thickness.

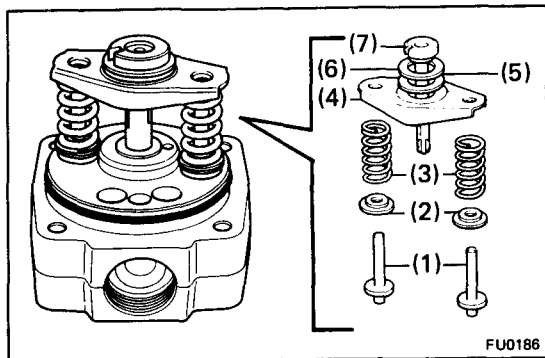

FU0186

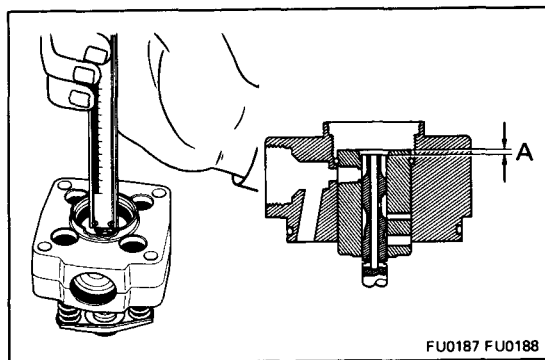

FU0187 FU0188

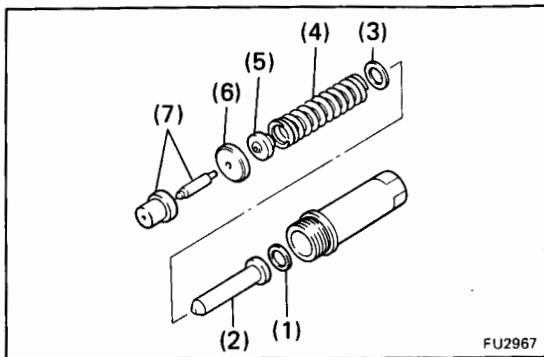

FU2967

2. (2L-T Austria)
ASSEMBLY AND ADJUSTING PILOT INJECTION (PIJ) ACTUATOR

- (a) Install the following parts to the holder body.
- (1) Adjusting shim (for piston lift gap)
 - (2) Stopper
 - (3) Adjusting shim (for opening pressure)
 - (4) Pressure spring
 - (5) Pressure pin
 - (6) Distance piece
 - (7) Accumulator assembly

NOTICE: Do not mix up the shims in (1) and (3) above.

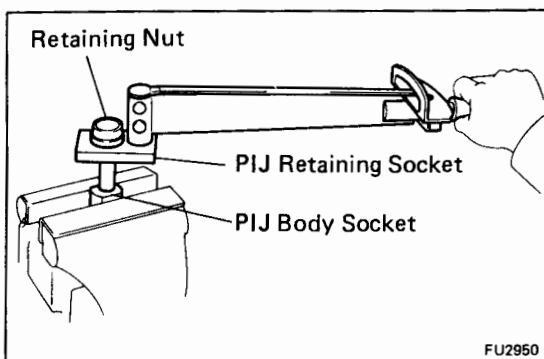

FU2950

- (b) Using the PIJ body socket and PIJ retaining socket, install the retaining nut.

Part No. 95096-10390 and 95096-10400 (NIPPONDENSO)

Torque: 675 kg-cm (49 ft-lb, 66 N-m)

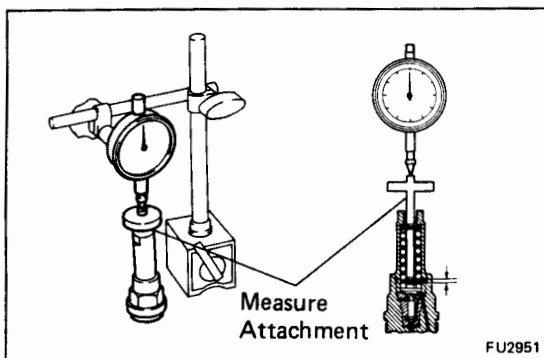

FU2951

- (c) Place the PIJ actuator and magnet stand on top of the surface plate, insert the measure attachment in the thread hole in the plug bolt, and set the dial gauge.

Part No. 95096-10420 (NIPPONDENSO)

- (d) Set the dial indicator scale to 0 mm (0 in.) on top of the measure attachment.

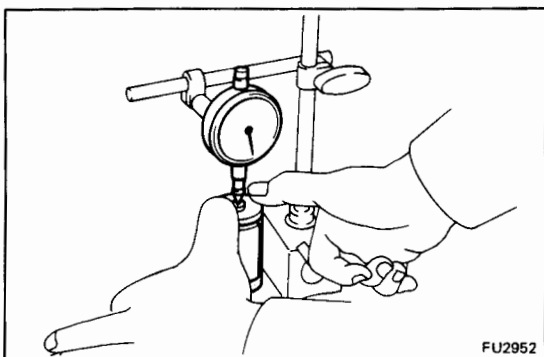

FU2952

- (e) Press down on the edges of the measure attachment and measure the piston lift gap.

**Piston lift gap: 0.175 – 0.475 mm
 (0.00689 – 0.01870 in.)**

If the piston lift gap is not as specified, change the shim.
 (See page FU-14)

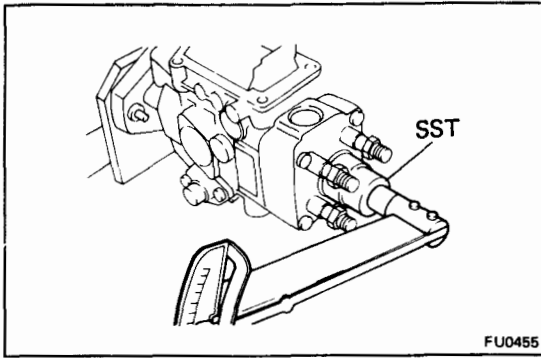

3. (2L-T Austria) CHECK PLUNGER STROKE

NOTICE: Perform this only when overhauling the injection pump itself.

(a) Using SST, install the conventional distributive head plug.

SST 09260-54012 (09262-54010)

Torque: 700 kg-cm (51 ft-lb, 69 N-m)

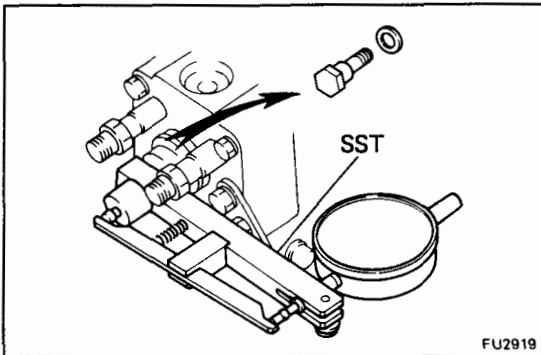

(b) Remove the plug bolt from the distributive head plug and gasket of the injection pump.

(c) Install SST (plunger stroke measuring tool) and a dial indicator to the plug bolt hole of distributive head plug.

SST 09275-54010

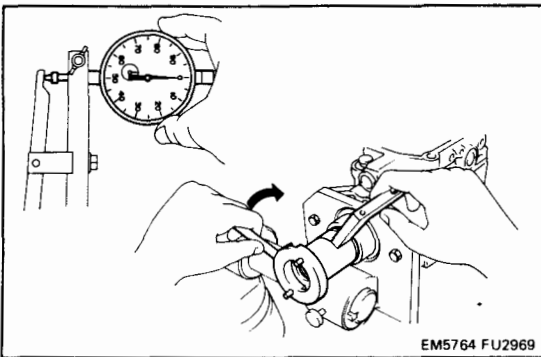

(d) Install the marking guide to the drive shaft, align the plunger with lower dead center and set the dial indicator at 0 mm (0 in.).

Part No. 95096-10430 (NIPPONDENSO)

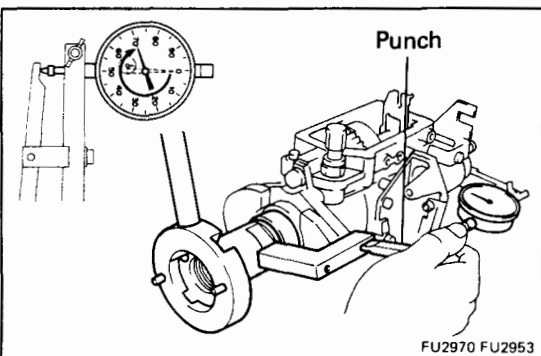

(e) Rotate the drive shaft in the pump rotation direction and use a punch to engrave the flange when the plunger lift (plunger stroke) is at maximum valve.

Part No. 95096-10440 (NIPPONDENSO)

Plunger stroke: 0.60 – 0.80 mm (0.0236 – 0.0315 in.)

NOTICE: If the old mark and new mark are located in different positions, file off the old mark.

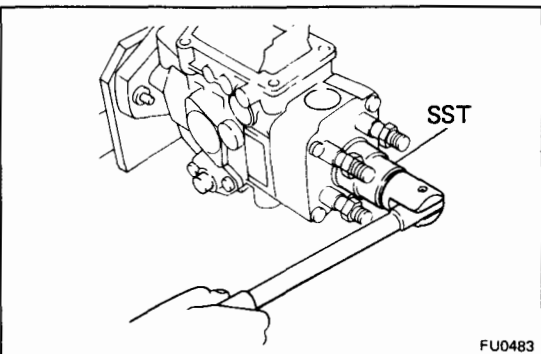

(f) Using SST, remove the distributive head plug.

SST 09260-54012 (09262-54010)

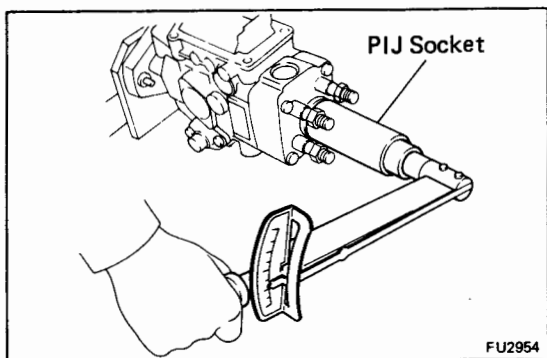

**4. (2L-T Austria)
INSTALL PILOT INJECTION (PIJ) ACTUATOR**

- (a) Install a new O-ring to the PIJ actuator.
- (b) Using the PIJ socket, install the PIJ actuator.

Part No. 95096-10380 (NIPPONDENSO)

Torque: 900 kg-cm (65 ft-lb, 88 N-m)

NOTICE: Check that the PIJ actuator and injection are clean and free of foreign material.

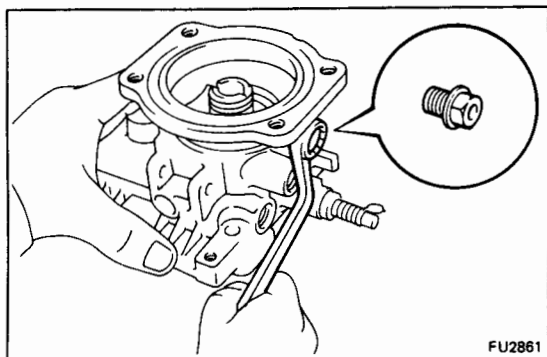

**5. (2L-T)
ASSEMBLE BOOST COMPENSATOR**

A. Install No. 2 overflow screw

Install the No. 2 overflow screw and cover.

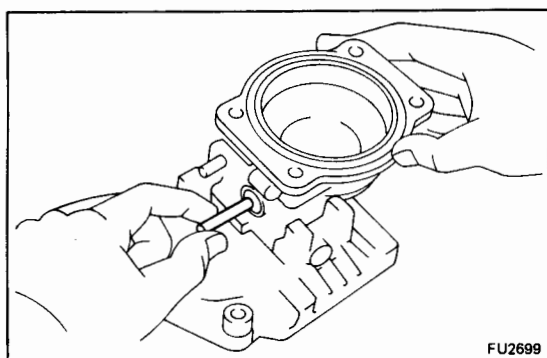

B. Install control lever

- (a) Insert the connecting pin into the governor cover.

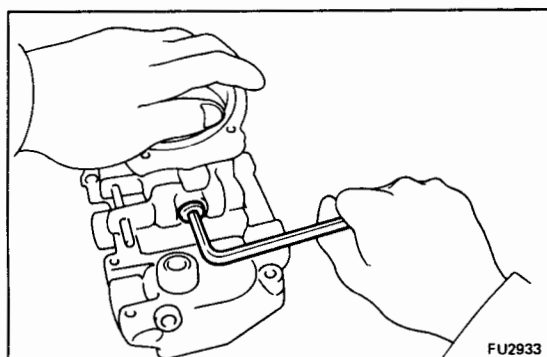

- (b) Using a 4 mm hexagonal wrench, install the plug with a new gasket.

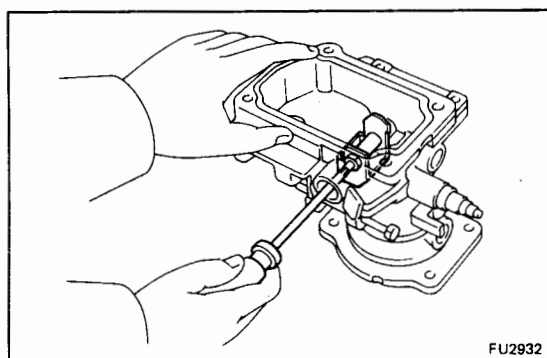

- (c) Using a small screwdriver, install the control lever with the support pin.

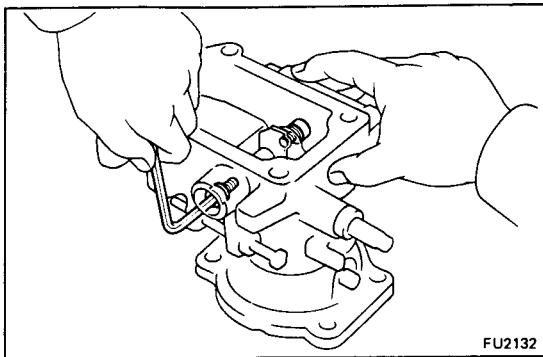

- (d) Using a 4 mm hexagonal wrench, install two new gas-kets and the two bolts.

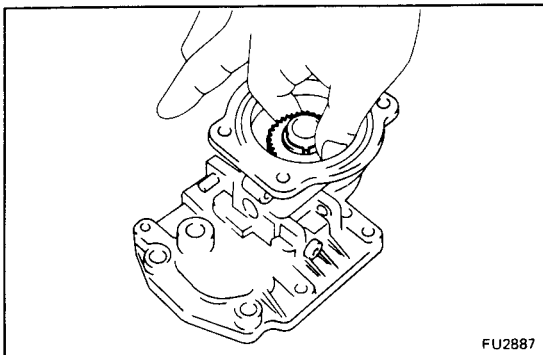

C. Install guide bushing

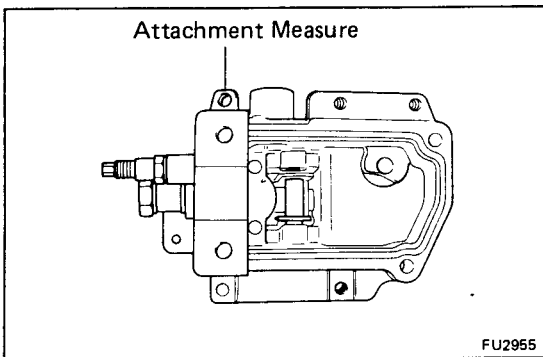

D. Install boost compensator diaphragm

- (a) Install the attachment measure to the governor cover. Part No. 95096-10330 (NIPPONDENSO)

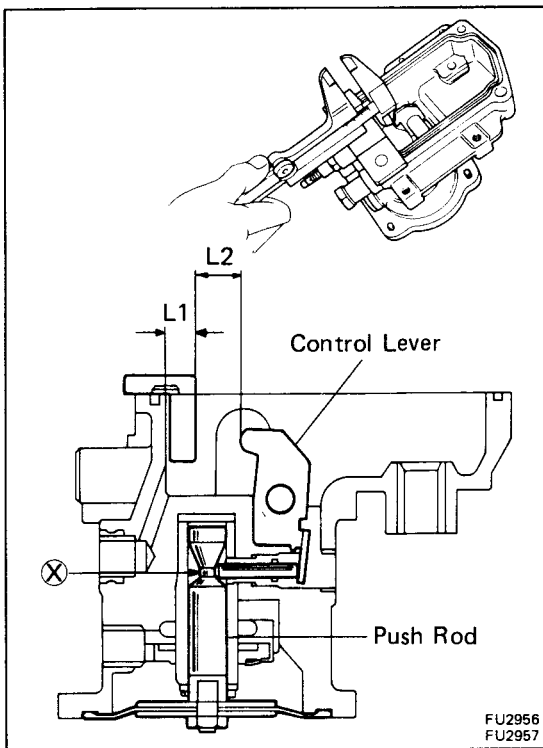

- (b) Measure the distance between the end surface of the control lever and the attachment measure.

- (1) Install the shim and diaphragm.

HINT: Do not assemble the spring.

- (2) With the push rod against the ⊗ surface (flat part), measure dimension "L2" with vernier calipers as shown.

Dimension "L2":

- Austria Approx. 10.75 mm (0.4232 in.)
Others Approx. 10.39 mm (0.4091 in.)

HINT: Dimension "L1" of attachment measure is 10 mm (0.39 in.).

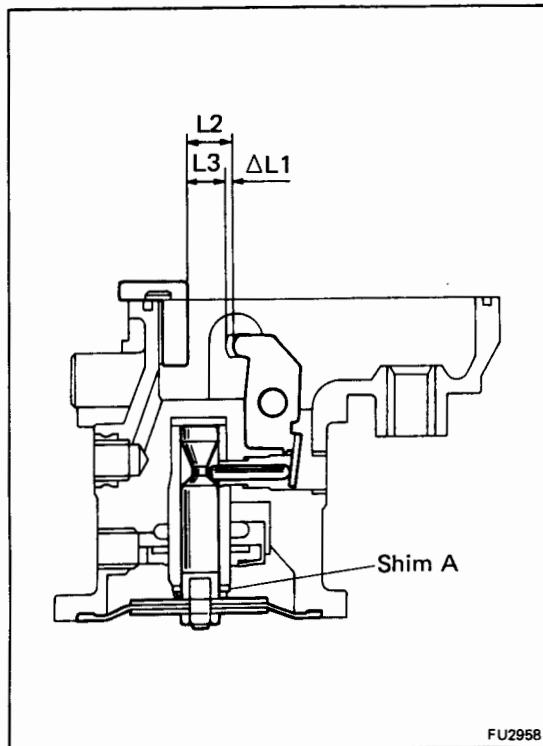

- (3) With the push rod pushed in to the maximum, measure dimension "L3" with vernier calipers as shown. Select shim A to adjust "ΔL1" obtained as the difference between "L3" and "L2" obtained in (2) above.

Difference "ΔL1":

Austria 0.67 – 0.97 mm (0.0264 – 0.0382 in.)
 Others 1.23 – 1.33 mm (0.0484 – 0.0524 in.)

Adjusting shim thickness:

- 1.1 mm (0.043 in.)
- 1.3 mm (0.051 in.)
- 1.5 mm (0.059 in.)
- 1.7 mm (0.067 in.)
- 1.9 mm (0.075 in.)
- 2.1 mm (0.083 in.)
- 2.3 mm (0.090 in.)
- 2.5 mm (0.098 in.)
- 2.7 mm (0.106 in.)
- 2.9 mm (0.114 in.)
- 3.1 mm (0.122 in.)
- 3.3 mm (0.130 in.)

- (4) Remove the diaphragm and push rod.

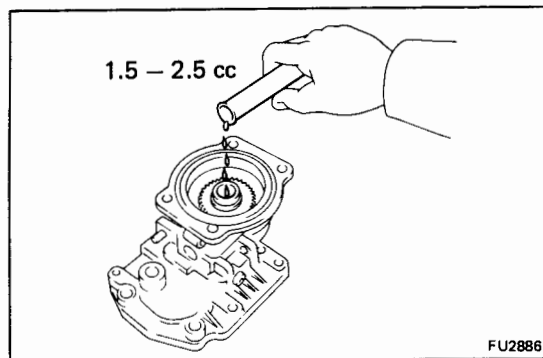

- (c) Insert 1.5 – 2.5 cc (0.09 – 0.15 cu in.) of engine oil into the bushing hole.

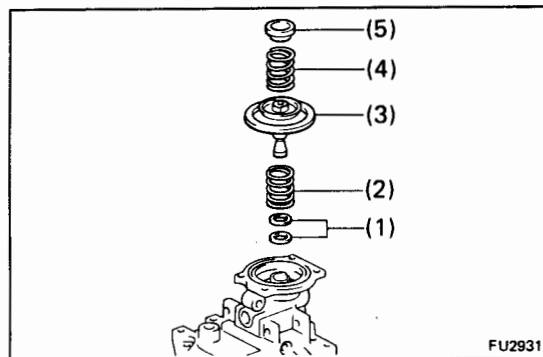

- (d) Install the following parts:

- (1) Boost compensator shim A
- (2) Main spring
- (3) Diaphragm and push rod
- (4) Sub spring (Austria only)
- (5) Boost compensator shim B (Austria only)

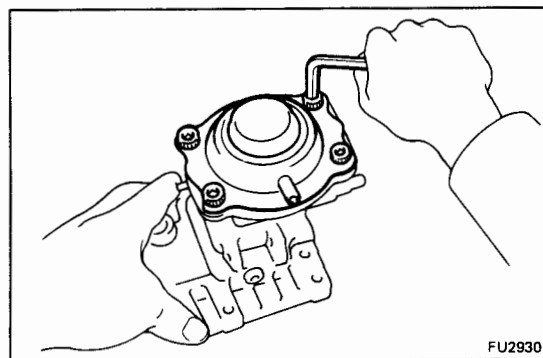

- (e) Using a 5 mm hexagonal wrench, install the four bolts and governor cover.

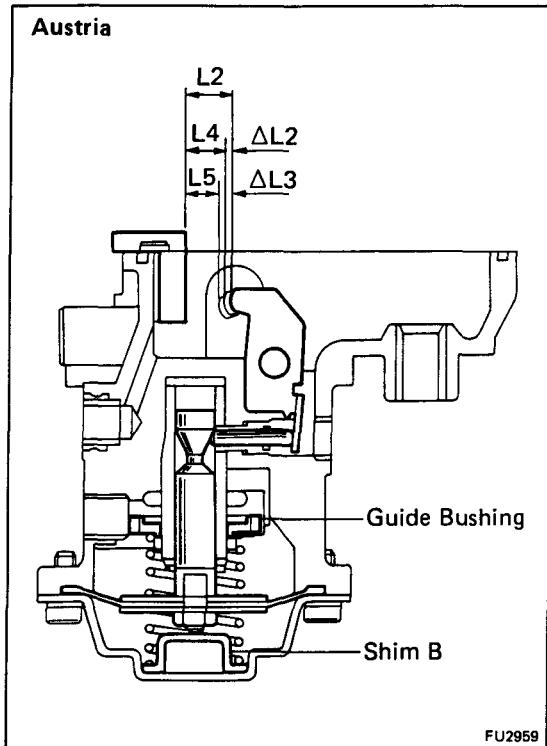

- (f) Measure the distance between the control lever end surface and the attachment measure.

(Austria)

- (1) Measure dimension "L4" with vernier calipers as shown.

Adjust the difference " $\Delta L2$ " between "L2" measured in (b) and "L4" by rotating the guide bushing.

Difference " $\Delta L2$ ": 1.30 – 1.50 mm (0.0512 – 0.0591 in.)

- (2) Apply 350 mmHg (13.8 in.Hg, 46.7 kPa) of absolute pressure to the boost compensator and measure dimension "L5" with vernier calipers as shown. Select shim B to adjust " $\Delta L3$ " obtained as the difference between "L5" and "L2" measured in (b).

Difference " $\Delta L3$ ": 1.70 – 1.94 mm (0.0669 – 0.0764 in.)

Adjusting shim thickness: 12.90 mm (0.508 in.)

13.15 mm (0.518 in.)

13.40 mm (0.528 in.)

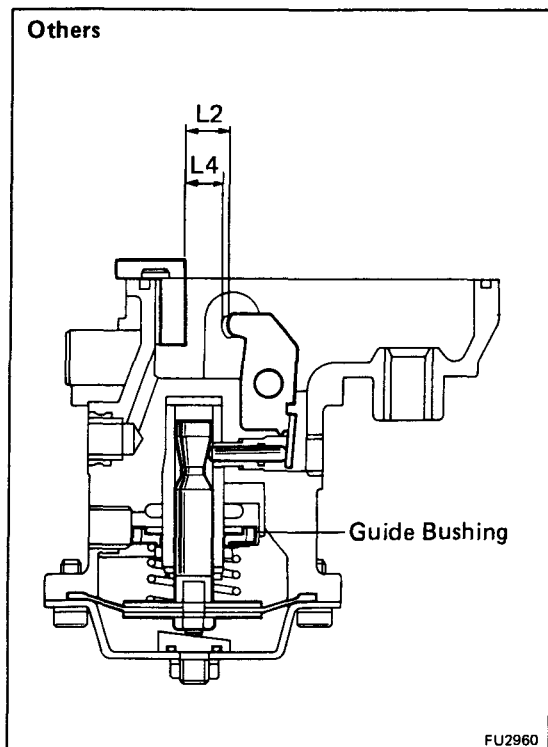

(Others)

Apply 0.27 kg/cm² (3.8 psi, 26 kPa) of pressure to the boost compensator and measure dimension "L4" with vernier calipers as shown.

Adjust "L4" by rotating the guide bushing.

Dimension "L4": 9.85 – 9.95 mm (0.3878 – 0.3917 in.)

- (g) Remove the attachment measure.

Part No. 95096 – 10030 (NIPPONDENSO)

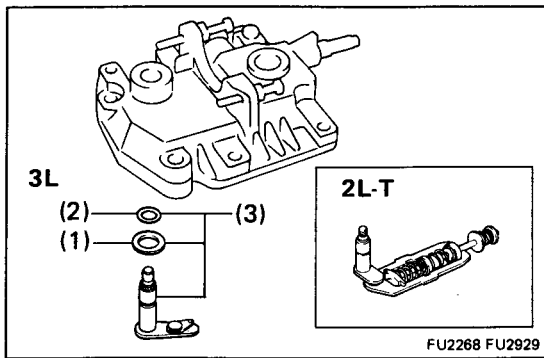

6. INSTALL ADJUSTING LEVER SHAFT TO GOVERNOR SHAFT

Install the following parts to the governor cover:

- (1) Plate washer
- (2) New O-ring
- (3) Adjusting lever shaft, O-ring and plate washer assembly

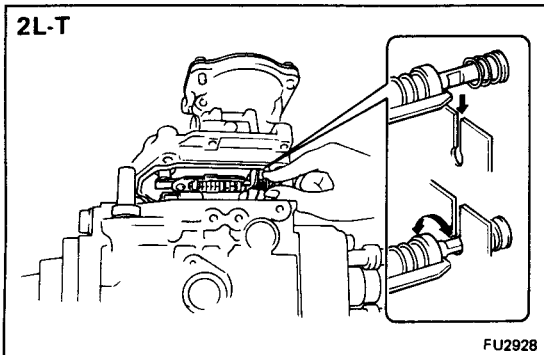

7. INSTALL GOVERNOR COVER

(a) Install a new gasket to the groove of the governor cover.

(b) (2L-T)
Connect the adjusting lever shaft to the governor link and twist the shaft lightly.

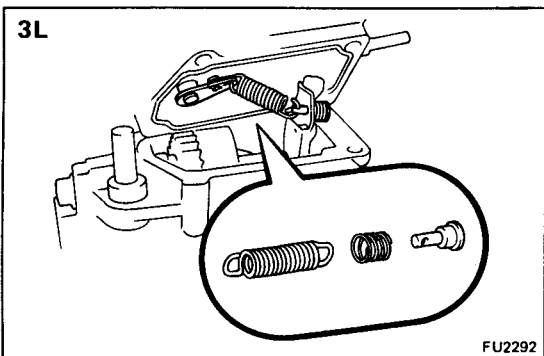

(c) (3L)
Install the speed control spring to the adjusting lever shaft.

(d) (3L)
Install the damper spring and spring seat, and connect the speed control spring to the spring seat.

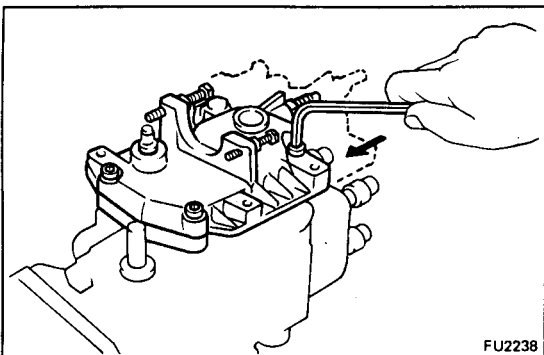

(e) Using a 5 mm hexagonal wrench, install the governor cover with the four bolts.

Torque: 85 kg-cm (74 in.-lb, 8.3 N-m)

HINT: Use the bolt which is 35 mm (1.38 in.) length.

(f) (2L-T and w/ HAC)
Install the idle speed adjusting screw.

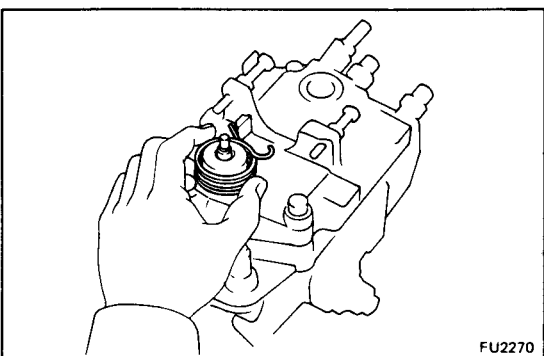

8. INSTALL ADJUSTING LEVER

(a) Place the return spring on the governor cover.

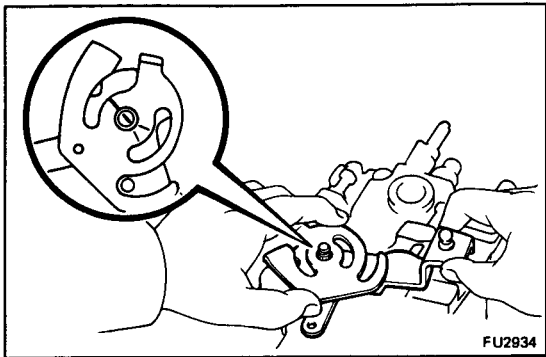

- (b) Hook the return spring to the adjusting lever, and turn and place the adjusting lever on the governor shaft.
- (c) Align the lines of the adjusting lever shaft and adjusting lever.

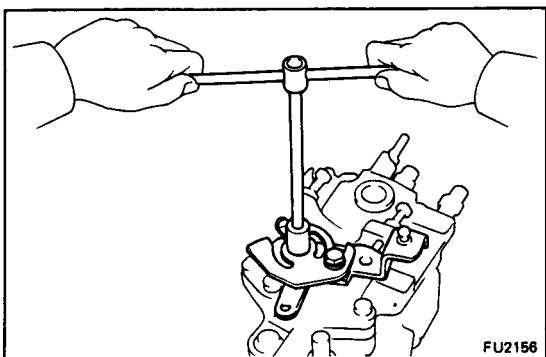

- (d) Install the adjusting lever with the nut.

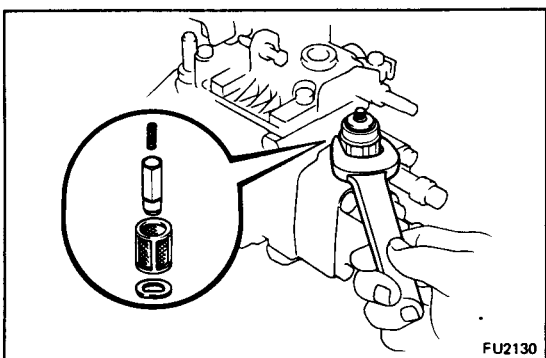

9. INSTALL FUEL CUT SOLENOID

- (a) Install a new O-ring on the fuel cut solenoid.
- (b) Install the strainer, valve, spring, a new gasket and the fuel cut solenoid.

Torque: 225 kg-cm (16 ft-lb, 22 N-m)

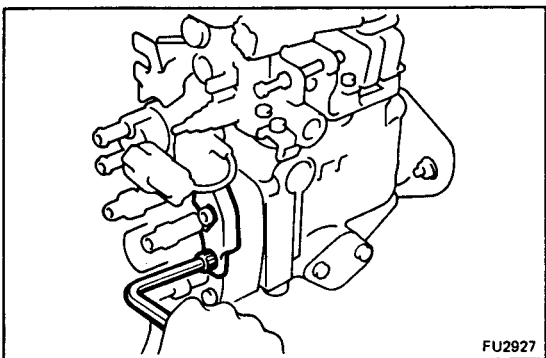

- (c) Install the lead wire to the fuel cut solenoid with the nut.
- (d) Install the dust cover to the fuel cut solenoid.
- (e) Install the lead wire connector to bracket.
- (f) Using a 6 mm hexagonal wrench, install the connector bracket with the bolt.

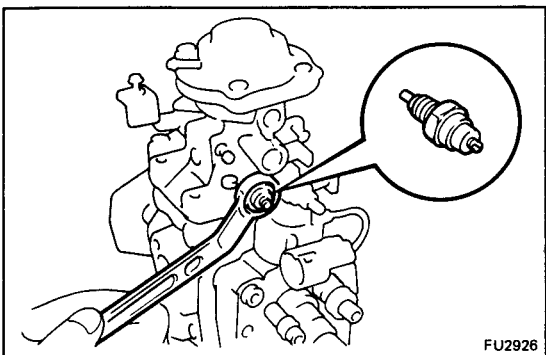

10. (2L-T) INSTALL DASH POT

Install a new gasket and the dash pot.

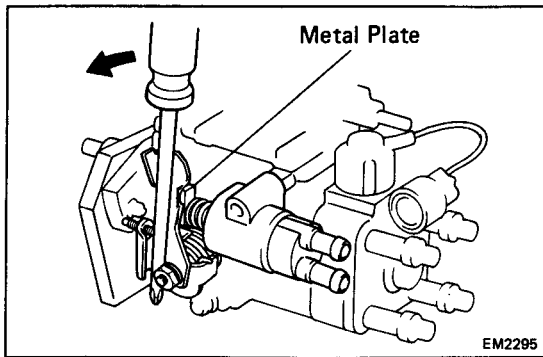

**11. (2L-T)
INSTALL THERMO WAX**

- (a) Using a screwdriver, turn the cold starting lever counterclockwise approx. 20°.
- (b) Put a metal plate (thickness of 8.5 – 10 mm (0.335 – 0.384 in.)) between the cold starting lever and thermo wax plunger.

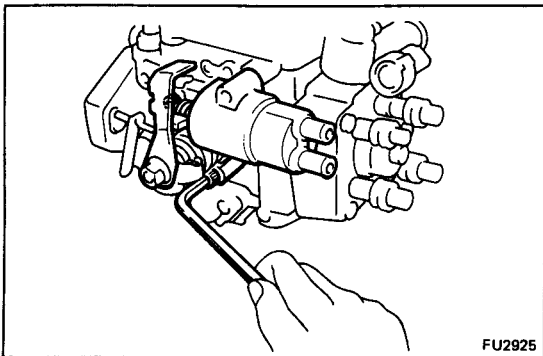

- (c) Install a new O-ring to the pump body.
- (d) Using a 5 mm hexagonal wrench, install the thermo wax with the two bolts.

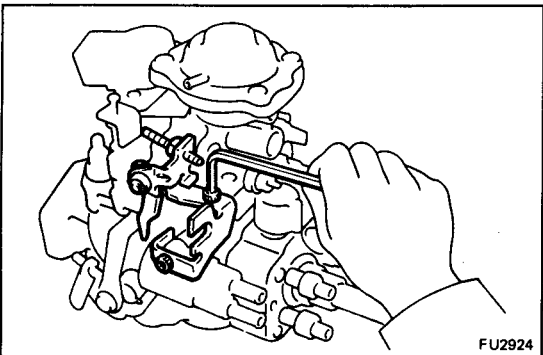

**12. (2L-T)
INSTALL IDLE-UP LEVER**

Using a 5 mm hexagonal wrench, install the idle-up lever with the three bolts.

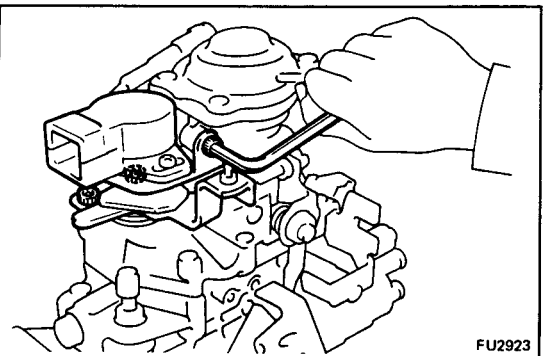

**13. (2L-T Austria)
INSTALL AND CHECK THROTTLE POSITION SENSOR**

- (a) Using a 5 mm hexagonal wrench, install the throttle position sensor with the three bolts.

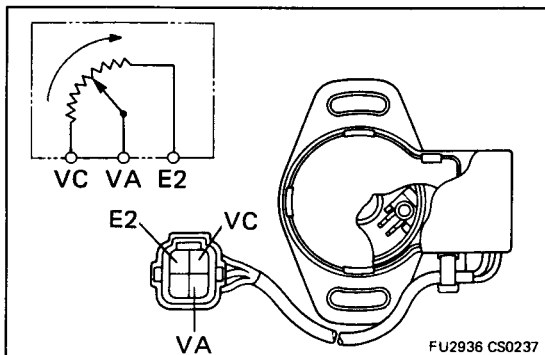

- (b) Using an ohmmeter, check that there is continuity between the terminals VC and E2.

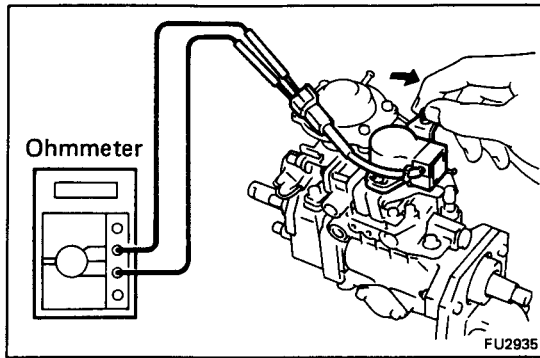

- (c) Using an ohmmeter, measure the resistance between terminals VA and E2.

Resistance: As the opening angle of the adjusting lever increases, the resistance should continue to decrease.

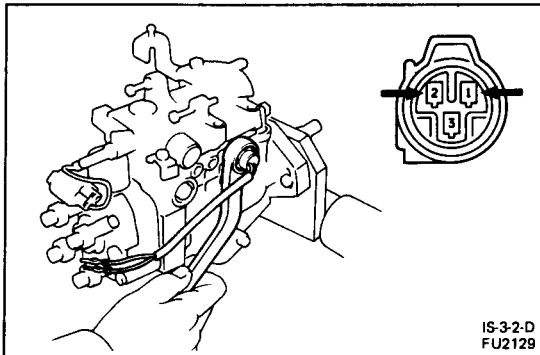

**14. (w/ Tachometer)
INSTALL PICKUP SENSOR**

- (a) Install a new O-ring and pickup sensor.
(b) Connect the two lead wires to the connector.

Torque: 210 kg-cm (15 ft-lb, 21 N-m)

**15. (w/ A/C)
INSTALL IDLE-UP ACTUATOR**

**16. REMOVE INJECTION PUMP FROM SST (STAND)
SST 09241-76022 and 09245-54010**

17. PERFORM AIR TIGHT TEST

- (a) Install a bolt to the overflow port.

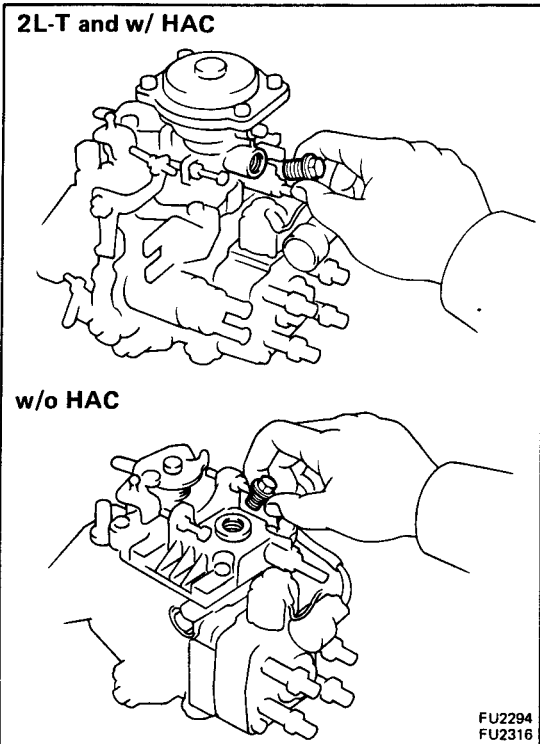

- (b) Connect an air hose to the fuel inlet pipe and place the injection pump into diesel fuel.

NOTICE: On vehicles with the throttle position sensor (2L-T Austria), be careful not to immerse sensor in diesel fuel.

- (c) Apply 0.5 kg/cm² (7 psi, 49 kPa) of pressure and confirm that there are not leaks.
(d) Next check that there are no leaks with 5.0 kg/cm² (71 psi, 490 kPa) of pressure applied.

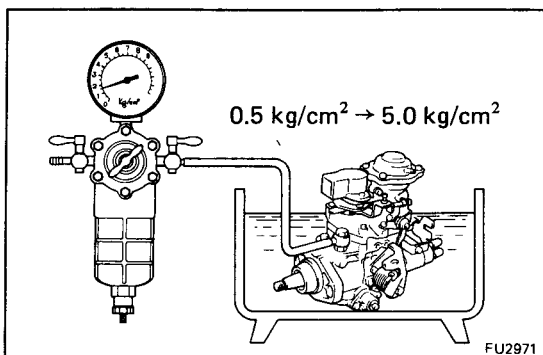

**18. INSTALL SET KEY OF INJECTION PUMP DRIVE
PULLEY ON DRIVE SHAFT**

ADJUSTMENT OF INJECTION PUMP

1. PRE-TEST CHECK AND PREPARATION

- (a) The specifications for test nozzle and nozzle holders are as follows.

Test nozzle: DN12SD12 (NIPPONDENSO)

Test nozzle opening pressure:

145 – 155 kg/cm²

(2,062 – 2,205 psi, 14,220 – 15,200 kPa)

- (b) Check the accuracy of the tachometer.

Allowable error: ± 40 rpm

- (c) Install the angle gauge stand.

- (d) Mount the injection pump body on the pump tester.

HINT: Place a mark on the key groove portion of the coupling.

- (e) Install an injection pipe with the following specifications.

Outer diameter: 6.0 mm (0.236 in.)

Inner diameter: 2.0 mm (0.079 in.)

Length: 840 mm (33.07 in.)

Minimum bending radius: 25 mm (0.98 in.) or more

- (f) Remove the fuel inlet hollow screw.

- (g) Connect the fuel inlet pipe with an adapter.

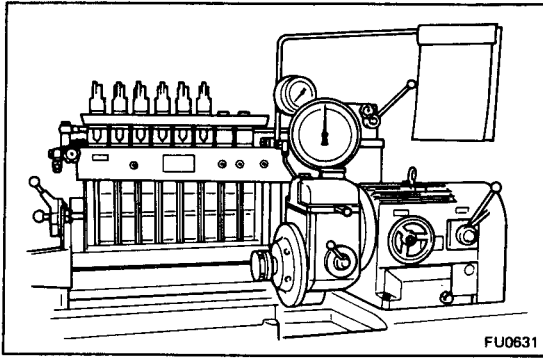

FU0631

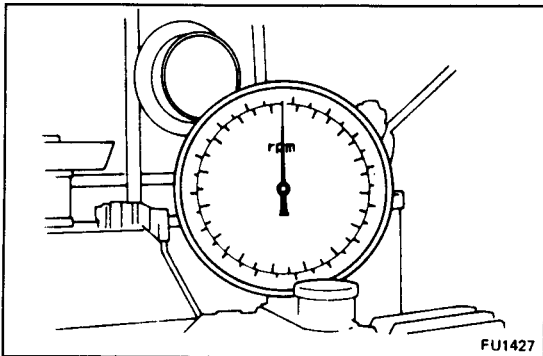

FU1427

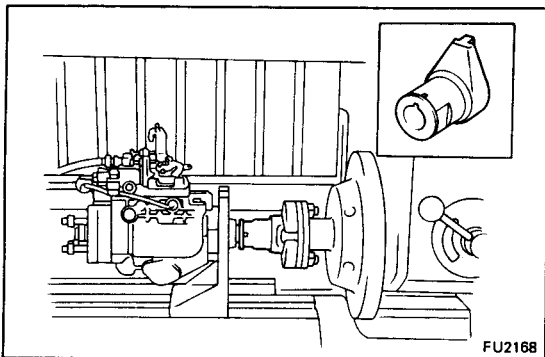

FU2168

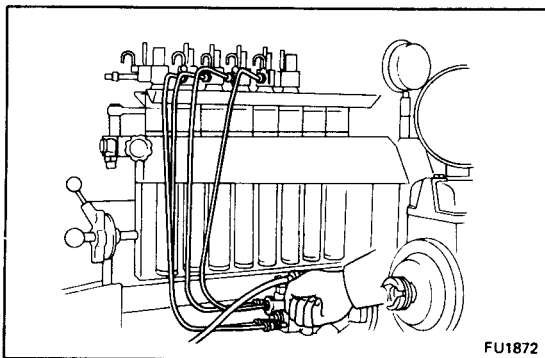

FU1872

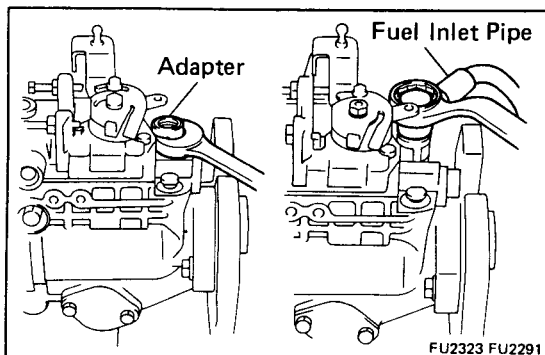

FU2323 FU2291

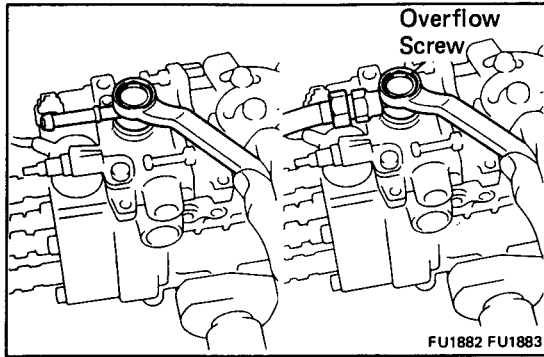

(h) Install the overflow hose with the overflow screw.
 HINT: Always use the overflow screw installed on the pump to be adjusted.

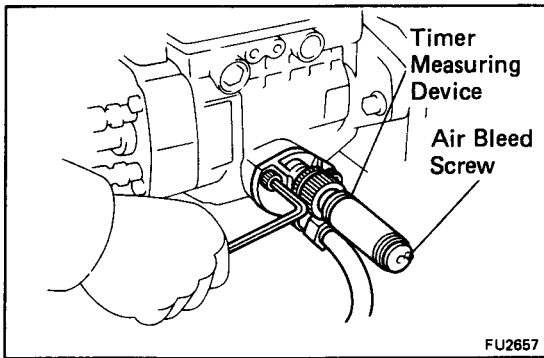

(i) Using a 5 mm hexagonal wrench, remove the two bolts and RH timer cover.
 (j) Install the inner pressure gauge with the timer measuring device.

Part No. 95095-10220 and 95095-10231 (NIPPONDENSO)

HINT: Bleed air by the air bleed screw.

(k) (2L-T)
 Connect SST (turbocharger pressure gauge) to the boost compensator.

SST 09992-00241

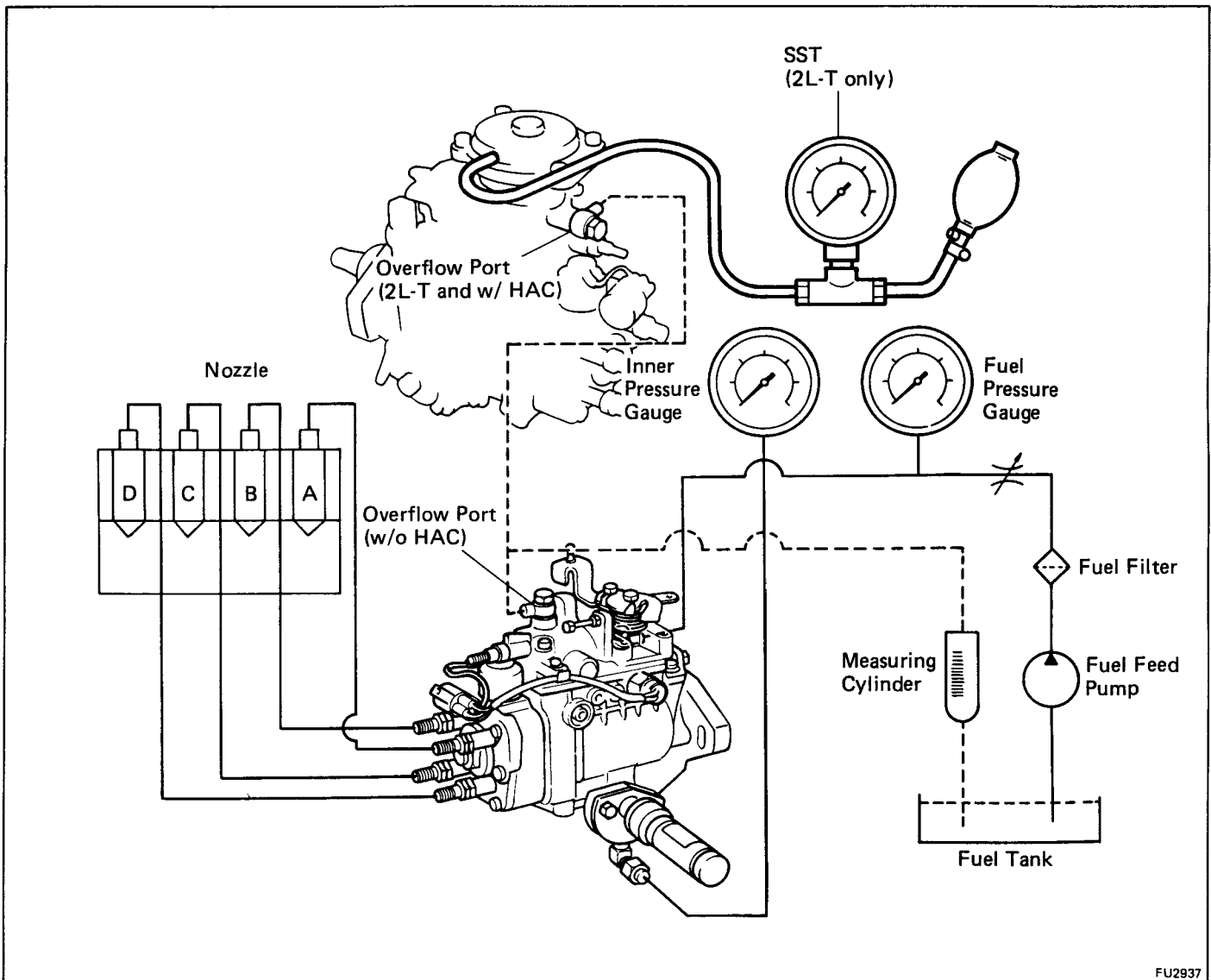

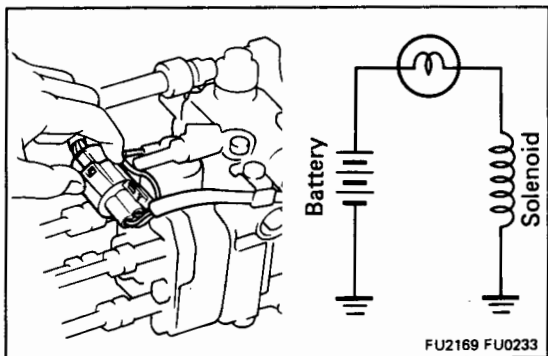

- (l) Apply about 6 volts of DC power to the fuel cut solenoid.

NOTICE:

- When applying voltage to the solenoid, position the battery as far away from the solenoid as possible so that a spark does not occur.
- When connecting the battery cable, connect the solenoid side first.

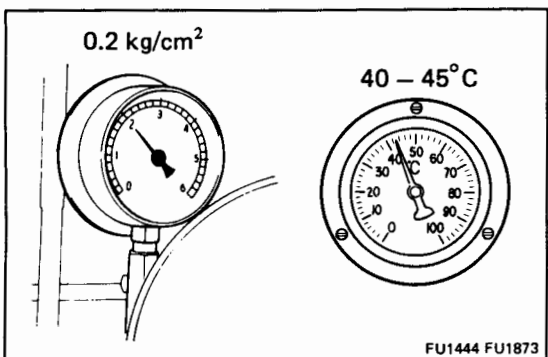

- (m) The pressure for feeding fuel to the injection pump should be 0.2 kg/cm² (2.8 psi, 20 kPa). The fuel temperature for pump testing should be 40 – 45°C (104 – 113°F).

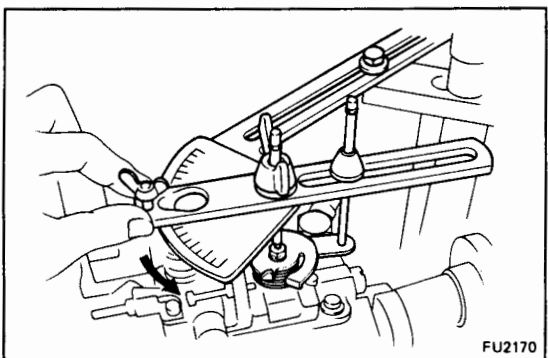

- (n) Install an angle gauge to the stand and set it to the adjusting lever.
- (o) Secure the adjusting lever fully on the maximum speed side.

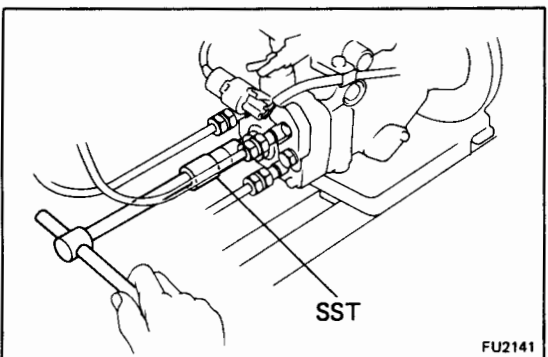

- (p) Check the installation direction of the camplate as follows:

- Disconnect the injection pipe from the position marked "C" on the distributive head.
- Using SST, remove the delivery valve holder.

SST 09260-54012 (09269-54020)

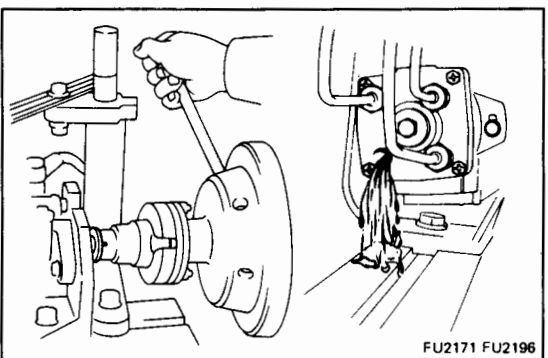

- Check that fuel is flowing out when the mark is in the position shown in the illustration. If not, it is improperly assembled.
- Disassemble and change the camplate position 180° in the opposite direction.

HINT: At this time, disconnect the fuel cut solenoid wire harness.

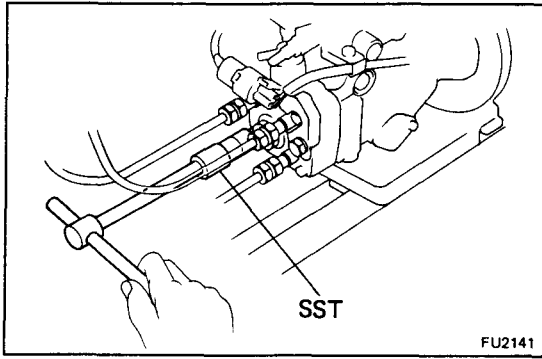

- Using SST, install the delivery valve holder.
SST 09260-54012 (09269-54020)
- Connect the injection pipe.

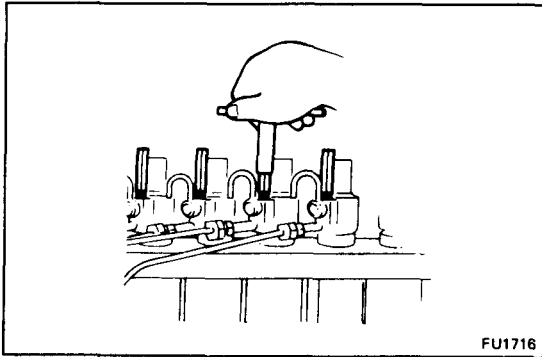

(q) Bleed the air from the injection pipes.

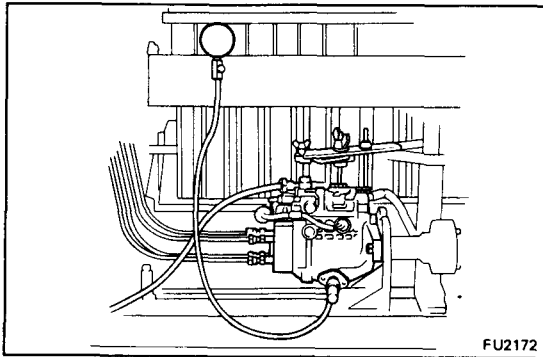

(r) Race the injection pump for 5 minutes at 2,000 rpm.
NOTICE: Check that there is no fuel leakage or abnormal noise.

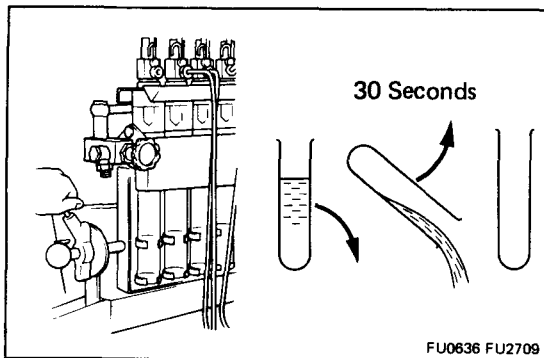

HINT:

- Measure the volume of each injection cylinder with a measuring cylinder.
- Before measuring the injection volume, first hold the cylinder tilted for at least 30 seconds to discard all the fuel.

2. PRE-SET FULL LOAD INJECTION VOLUME

- (a) Set the adjusting lever to maximum position.
- (b) (2L-T Austria)
Apply 0.68 kg/cm² (9.6 psi, 66 kPa) of pressure to the boost compensator.
- (c) (2L-T Others)
Apply 0.63 kg/cm² (9.0 psi, 62 kPa) of pressure to the boost compensator.
- (d) Measure the injection volume.

Item		Pump rpm	No. of measuring strokes	Injection volume cc (cu in.)
2L-T	Austria	1,400	200	14.04 – 14.36 (0.86 – 0.88)
	Others	1,200	200	13.94 – 14.26 (0.85 – 0.87)
3L	Hong Kong, Singapore, Malaysia	1,200	200	10.96 – 11.28 (0.67 – 0.69)
	Others	1,200	200	11.56 – 11.88 (0.71 – 0.72)

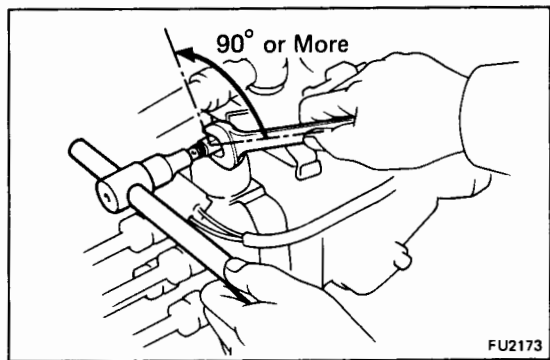

- (e) Remove the collar seal as follows:
 - Hold the full load set screw, and release the collar seal from the spot weld by turning the lock nut counterclockwise 90° or more.

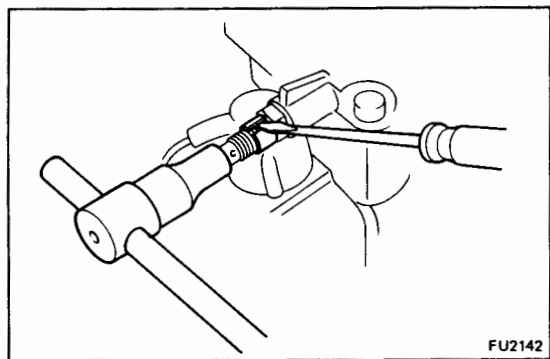

- Using a screwdriver, remove the collar seal.

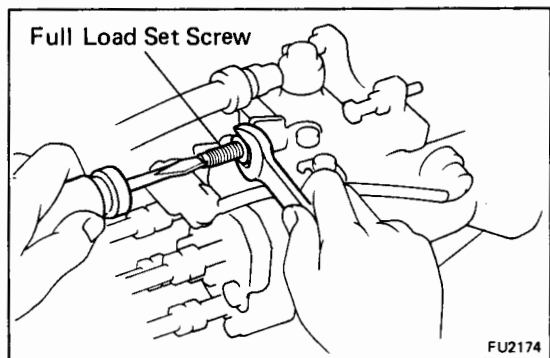

- (f) Adjust by turning the full load set screw.
HINT: The injection volume will increase about 3 cc (0.18 cu in.) with each 1/2 turn of the screw.

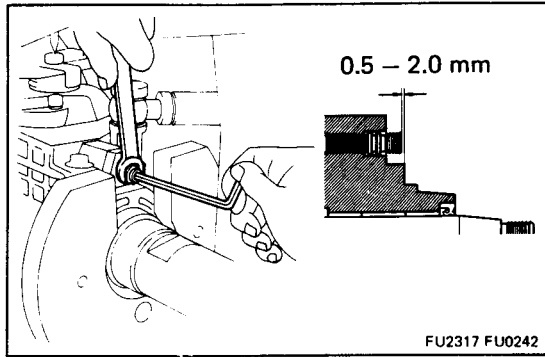

**3. (2L-T and w/o HAC)
PRE-SETTING OF LOAD SENSING TIMER**

Using a 5 mm hexagonal wrench, adjust the protrusion of the governor shaft.

Protrusion: 0.5 – 2.0 mm (0.020 – 0.079 in.)

4. PRE-SET MAXIMUM SPEED

- (a) Set the adjusting lever to maximum position.
- (b) (2L-T Austria)
Apply 0.68 kg/cm² (9.6 psi, 66 kPa) of pressure to the boost compensator.
- (c) (2L-T Others)
Apply 0.63 kg/cm² (9.0 psi, 62 kPa) of pressure to the boost compensator.
- (d) Measure the injection volume.

Item		Pump rpm	No. of measuring strokes	Injection volume cc (cu in.)
2L-T	Austria	2,450	200	4.3 – 6.3 (0.26 – 0.38)
	Others	2,400	200	4.3 – 6.3 (0.26 – 0.38)
3L	Hong Kong, Singapore, Malaysia	2,200	200	4.6 – 6.2 (0.28 – 0.38)
	Others	2,300	200	4.6 – 6.2 (0.28 – 0.38)

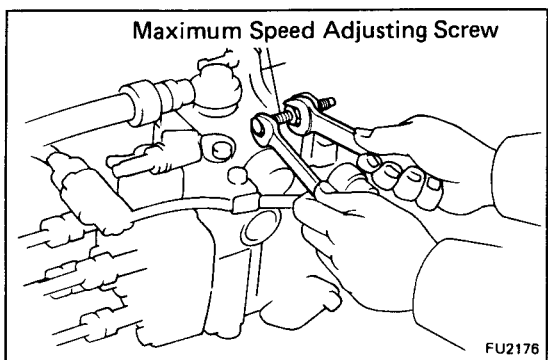

- (e) Cut off the seal wire.
- (f) Adjust the injection volume with the maximum speed adjusting screw.

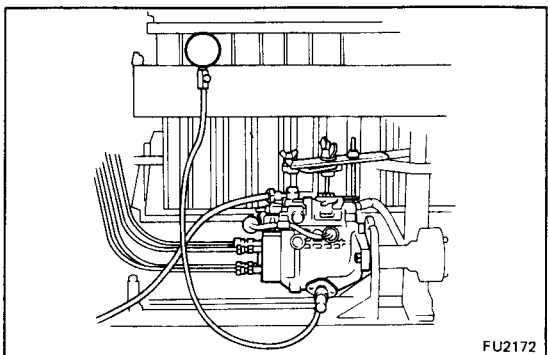

5. ADJUST PUMP INNER PRESSURE

- (a) Measure the pump inner pressure at the below listed rpm.

Pump rpm	Inner pressure kg/cm ² (psi, kPa)
500	3.2 – 3.8 (46 – 54, 314 – 373)
2,100	6.6 – 7.2 (94 – 102, 647 – 706)

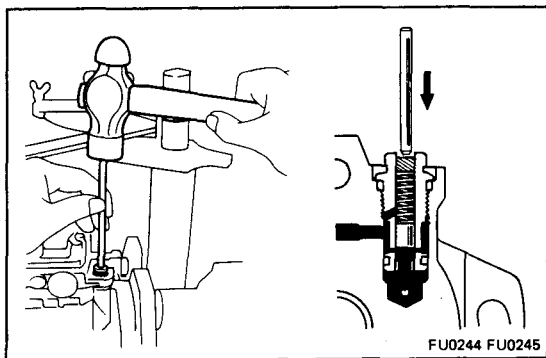

FU0244 FU0245

- (b) If the pressure is low, adjust by lightly tapping the regulator valve piston while watching the pressure gauge.

HINT: If the pressure is too high or if the regulator valve was tapped in too far, the regulator valve must be replaced.

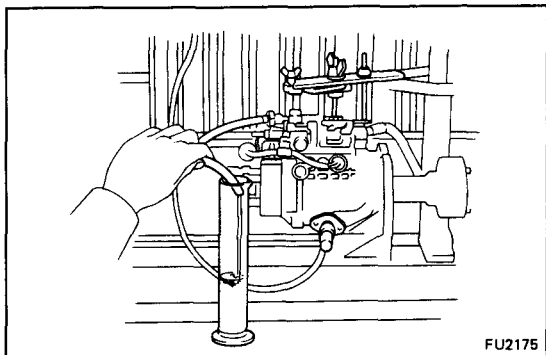

FU2175

6. CHECK OVERFLOW VOLUME

Measure the overflow volume at the below listed rpm.

Pump rpm	Overflow volume cc/min. (cu in./min.)
2,200	370 – 800 (22.6 – 48.8)

HINT: Always use the overflow screw installed on the pump to be adjusted.

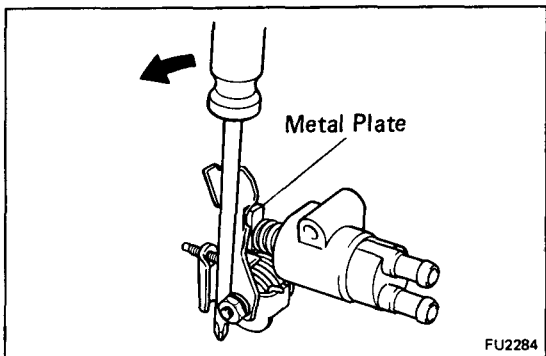

FU2284

7. (2L-T) RELEASE COLD STARTING SYSTEM FOR NEXT INSPECTIONS

- (a) Using a screwdriver, turn the cold starting lever counterclockwise approx. 20°.
- (b) Put a metal plate (thickness of 8.5 – 10 mm (0.33 – 0.39 in.)) between the cold starting lever and thermo wax plunger.

HINT: Keep the cold starting system released until all measurements and adjustments are finished.

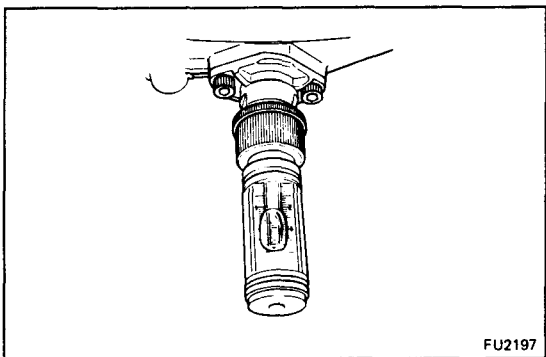

FU2197

8. ADJUST TIMER

- (a) Set the timer measuring device at zero.
- (b) Measure the piston stroke at the below listed rpm.

Item	Pump rpm	Piston stroke	
		mm (in.)	
2L-T	Austria	800	1.2 – 2.0 (0.047 – 0.079)
		1,200	2.5 – 3.3 (0.098 – 0.130)
		2,000	5.4 – 6.0 (0.213 – 0.236)
		2,300	5.4 – 6.0 (0.213 – 0.236)
	Others	800	1.4 – 2.2 (0.055 – 0.087)
		1,200	3.0 – 3.8 (0.118 – 0.150)
		1,800	5.5 – 6.3 (0.217 – 0.248)
		2,300	6.7 – 7.5 (0.264 – 0.295)
3L	800	0.6 – 1.4 (0.024 – 0.055)	
	1,200	1.8 – 2.6 (0.071 – 0.102)	
	2,000	4.4 – 5.2 (0.173 – 0.205)	
	2,300	4.7 – 5.5 (0.185 – 0.217)	

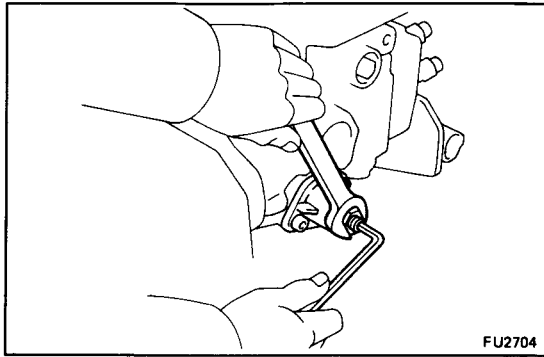

FU2704

HINT: Check that the hysteresis is within 0.3 mm (0.012 in.).

(c) Using a 5 mm hexagonal wrench, adjust by the timer adjusting screw.

HINT: The stroke will decrease with turn to clockwise and increase with turn to counterclockwise.

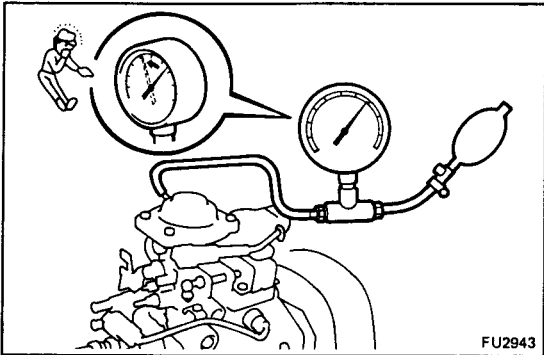

FU2943

9. (2L-T) CHECK AIR TIGHTNESS OF BOOST COMPENSATOR

(a) Apply 1.36 kg/cm² (19.3 psi, 133 kPa) of pressure to the boost compensator.

(b) Measure the time it takes for the pressure to drop to 1.33 kg/cm² (18.9 psi, 130 kPa).

Pressure drop: 10 seconds or more

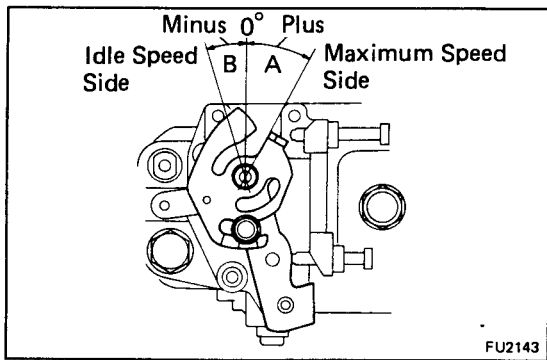

FU2143

10. ADJUST FULL LOAD INJECTION VOLUME

(a) The adjusting lever angle for the adjustment below should be as shown in the illustration.

Adjusting lever angle	
A (Maximum speed side)	B (Idle speed side)
Plus 23.5 – 33.5°	Minus 12.5 – 22.5°

(b) (2L-T Austria)
Apply 0.68 kg/cm² (9.6 psi, 66 kPa) of pressure to the boost compensator.

(c) (2L-T Others)
Apply 0.63 kg/cm² (9.0 psi, 62 kPa) of pressure to the boost compensator.

(d) Measure the full load injection volume.

Item		Adjusting lever angle position	Pump rpm	No. of measuring strokes	Injection volume cc (cu in.)
2L-T	Austria	Plus 23.5 – 33.5°	1,400	200	14.04 – 14.36 (0.86 – 0.88)
	Others	Plus 23.5 – 33.5°	1,200	200	13.94 – 14.26 (0.85 – 0.87)
3L	Hong Kong, Singapore, Malaysia	Plus 23.5 – 33.5°	1,200	200	10.96 – 11.28 (0.67 – 0.69)
	Others	Plus 23.5 – 33.5°	1,200	200	11.56 – 11.88 (0.71 – 0.72)

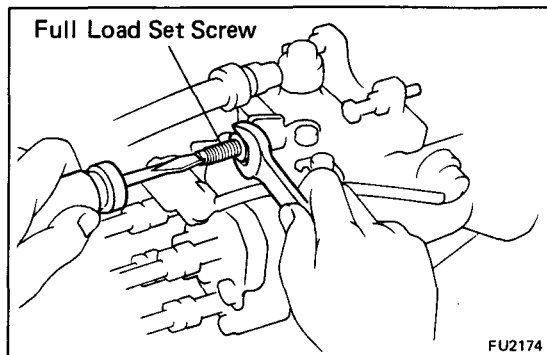

(e) Adjust by turning the full load set screw.

HINT: The injection volume will increase about 3 cc (0.18 cu in.) with each 1/2 turn of the screw.

11. ADJUST MAXIMUM SPEED

- (a) (2L-T Austria)
Apply 0.68 kg/cm² (9.6 psi, 66 kPa) of pressure to the boost compensator.
- (b) (2L-T Others)
Apply 0.63 kg/cm² (9.0 psi, 62 kPa) of pressure to the boost compensator.
- (c) Measure the injection volume at each pump rpm.

Item		Adjusting lever angle position	Pump rpm	No. of measuring strokes	Injection volume cc (cu in.)	Remarks
2L-T	Austria	Plus 23.5 – 33.5°	2,450	200	4.3 – 6.3 (0.26 – 0.38)	Adjust
			2,250		8.3 – 10.5 (0.51 – 0.64)	–
			2,750		1.3 (0.8) or less	–
	Others	Plus 23.5 – 33.5°	2,400	200	4.3 – 6.3 (0.26 – 0.38)	Adjust
			2,250		7.1 – 9.3 (0.43 – 0.57)	–
			2,750		1.3 (0.8) or less	–
3L	Hong Kong, Singapore, Malaysia	Plus 23.5 – 33.5°	2,200	200	4.6 – 6.2 (0.28 – 0.38)	Adjust
			2,000		8.44 – 10.44 (0.52 – 0.64)	–
			2,400		1.3 (0.8) or less	–
	Others	Plus 23.5 – 33.5°	2,300	200	4.6 – 6.2 (0.28 – 0.38)	Adjust
			2,100		9.08 – 11.08 (0.55 – 0.68)	–
			2,550		1.3 (0.8) or less	–

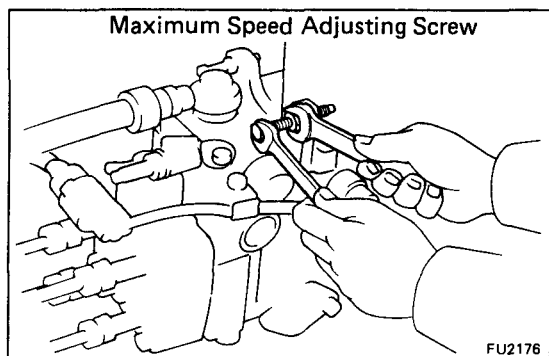

(d) Adjust by turning the maximum speed adjusting screw.

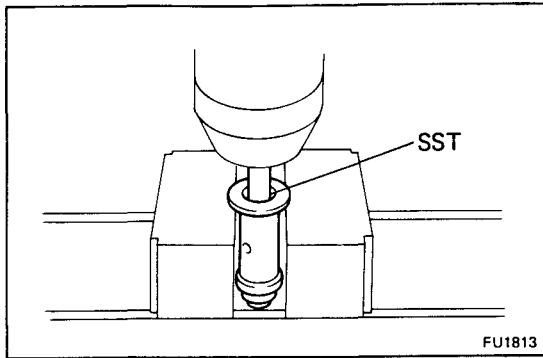

If the injection volume at 100 rpm is not as specified, replace the governor sleeve plug as follows:

- Using SST and a press, press out the sleeve plug assembly from the governor sleeve.

SST 09236-00101 (09237-00070)

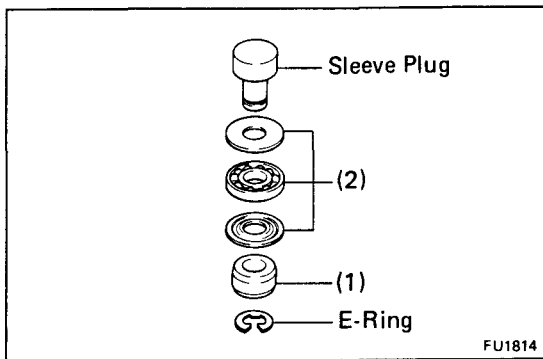

- Remove the E-ring and following parts from the sleeve plug:

- (1) Stop ring
- (2) Bearing and two bearing retainers

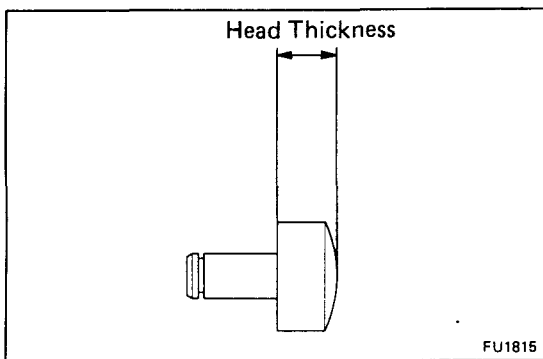

- Measure the head thickness of the sleeve plug, and select a new sleeve plug.

Sleeve plug head thickness		mm (in.)
3.0 (0.118)	3.5 (0.138)	4.0 (0.158)
3.1 (0.122)	3.6 (0.142)	4.1 (0.161)
3.2 (0.126)	3.7 (0.146)	4.2 (0.165)
3.3 (0.130)	3.8 (0.150)	
3.4 (0.134)	3.9 (0.154)	

HINT: Lengthening the plug 0.1 mm (0.004 in.) will increase injection volume by 0.6 cc (0.04 cu in.).

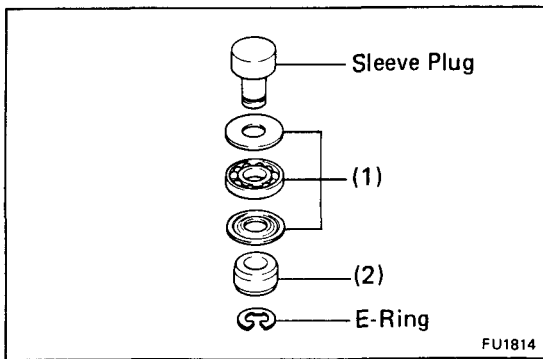

- Install the following parts to the new sleeve plug with a new E-ring:

- (1) Bearing and two retainers
- (2) Stop ring

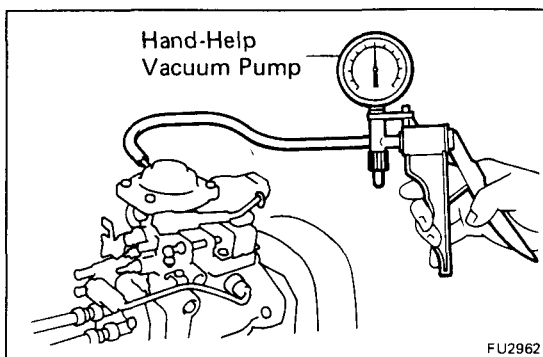

12. (2L-T) CHECK AND ADJUST FULL LOAD MINIMUM INJECTION VOLUME

- (Austria) Using the hand-help vacuum pump, apply 200 mmHg of (7.9 in.Hg, 26.7 kPa) absolute pressure to the boost compensator.

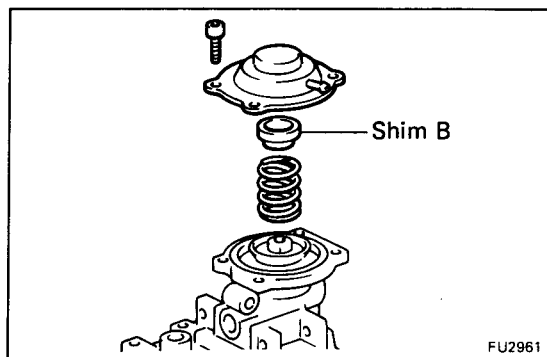

(b) Measure the injection volume

Item	Pump rpm	No. of measuring strokes	Injection volume cc (cu in.)
Austria	1,400	200	8.8 – 10.0 (0.54 – 0.61)
Others	500	200	10.6 – 11.4 (0.65 – 0.70)

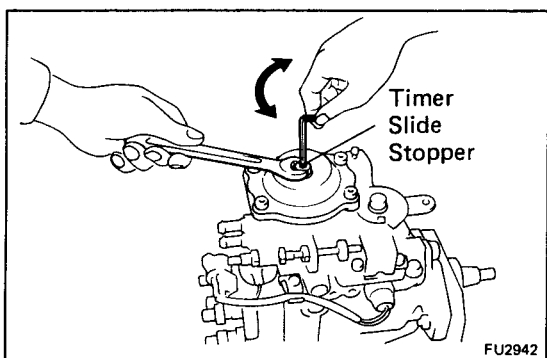

(c) (Austria)

If the injection volume is not as specified, adjust by using shim B. (See page FU-22)

(d) (Others)

Using a 3 mm hexagonal wrench, adjust the timer slide stopper.

13. (2L-T)

ADJUST BOOST COMPENSATOR CHARACTERISTIC

(Others)

- (a) Apply pressure to the boost compensator.
- (b) Measure the injection volume bushing.

Item	Pump rpm	Boost pressure kg/cm ² (psi, kPa)	No. of measuring strokes	Injection volume cc (cu in.)
Austria	500	0 (0, 0)	200	10.8 – 11.6 (0.65 – 0.71)
Others	1,200	0.41 (5.9, 40)	200	12.9 – 13.5 (0.79 – 0.82)

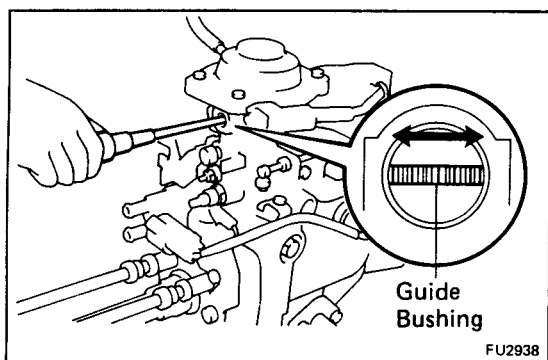

(c) Using a screwdriver, adjust the guide bushing.

HINT: When the guide bushing is turned clockwise, as seen from above, the injection volume will increase.

14. (2L-T)
INSPECT AND ADJUST BOOST COMPENSATOR
CHARACTERISTIC TENDENCY

- (a) Apply pressure to the boost compensator.
- (b) Measure injection volume.

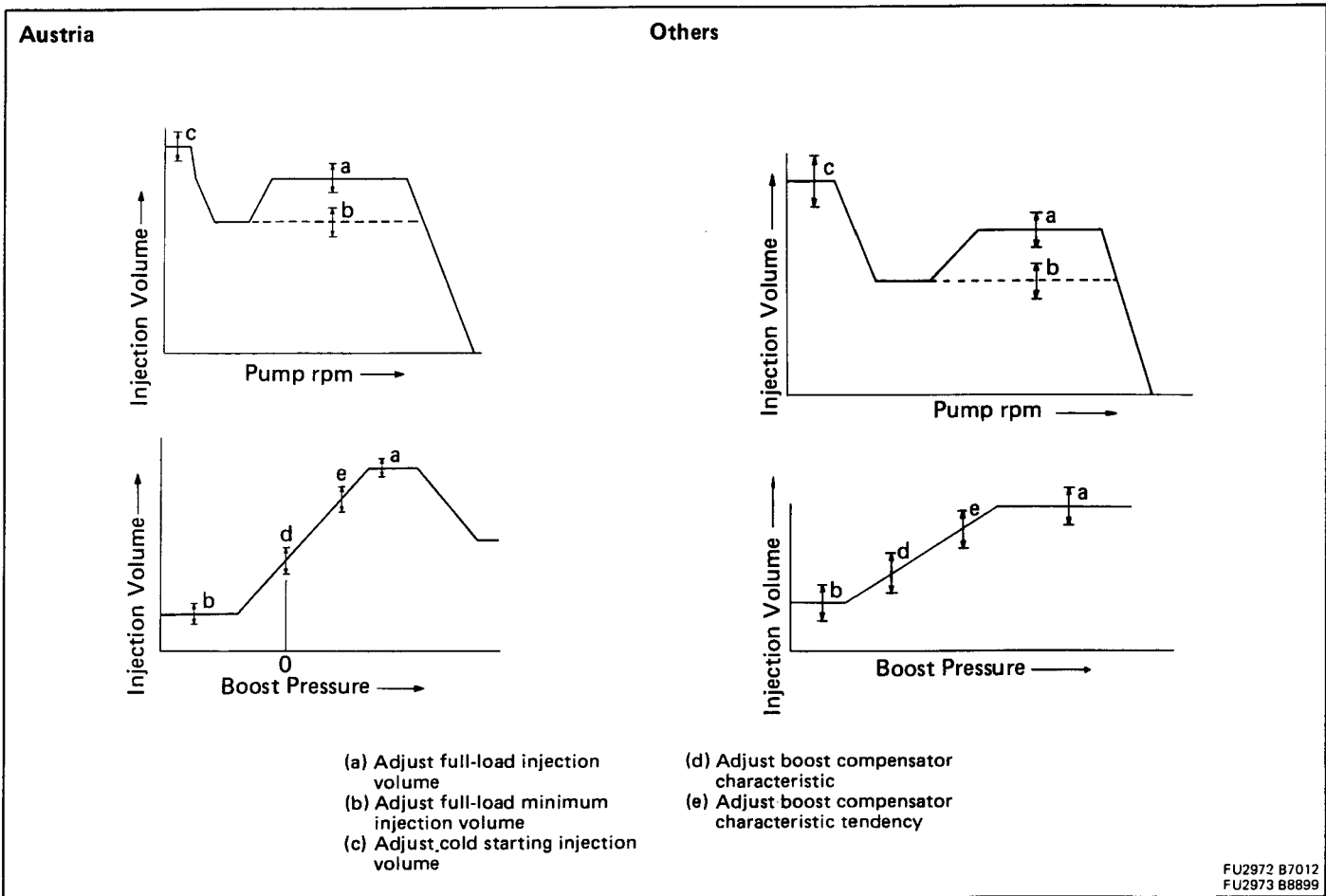

Item	Pump rpm	Boost pressure kg/cm ² (psi, kPa)	No. of measuring strokes	Injection volume cc (cu in.)
Austria	500	0.41 (5.9, 40)	200	14.6 – 15.4 (0.89 – 0.93)
Others	1,200	0.14 (1.9, 13)	200	11.2 – 12.0 (0.68 – 0.73)

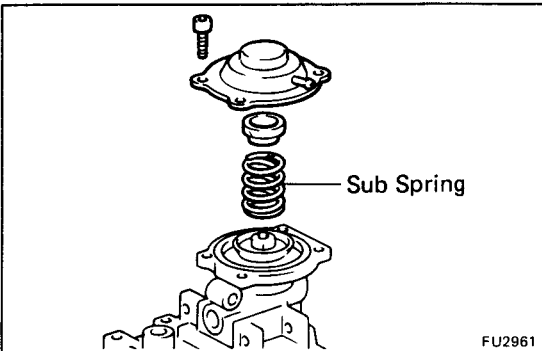

- (c) (Austria)
If the injection volume is not as specified, replace the sub spring of the boost compensator with one with different spring constant.

**Spring constant: 1.2 kg/cm (1.04 lb/in.)
1.4 kg/cm (1.22 lb/in.)**

**15. (2L-T)
CHECK HYSTERESIS**

(Austria)

Compare the injection volume when the boost compensator pressure is lowered from 0.74 kg/cm² (10.5 psi, 73 kPa) to 0 kg/cm² (0 psi, 0 kPa) and, conversely, when it is raised from zero.

(Others)

Compare the injection volume when the boost compensator pressure is lowered from 0.78 kg/cm² (11.1 psi, 77 kPa) to 0.14 kg/cm² (2.0 psi, 14 kPa) and, conversely, when it is raised from zero.

HINT: Make measurements after moving the adjusting lever between idle and maximum three times for each lowering of the pressure.

Item	Pump rpm	Boost pressure kg/cm ² (psi, kPa)	No. of measuring strokes	Injection volume cc (cu in.)	Hysteresis cc (cu in.)
Austria	1,400	0.74 (10.5, 73)	200	13.84 – 14.36 (0.84 – 0.88)	–
	1,400	0.68 (9.6, 66)		13.94 – 14.26 (0.85 – 0.87)	–
	500	0.41 (5.9, 40)		14.60 – 15.40 (0.89 – 0.94)	0.3 (0.02) or less
	500	0 (0, 0)		10.80 – 11.60 (0.66 – 0.71)	–
Others	1,200	0.74 (10.5, 73)	200	13.84 – 14.36 (0.84 – 0.88)	–
	1,200	0.63 (9.0, 62)		13.94 – 14.26 (0.85 – 0.87)	–
	1,200	0.41 (5.9, 40)		12.90 – 13.50 (0.79 – 0.82)	0.3 (0.02) or less
	1,200	0.14 (2.0, 14)		11.20 – 12.00 (0.68 – 0.73)	–

If not within standard value, check each sliding part of the boost compensator and check whether or not there is any oil.

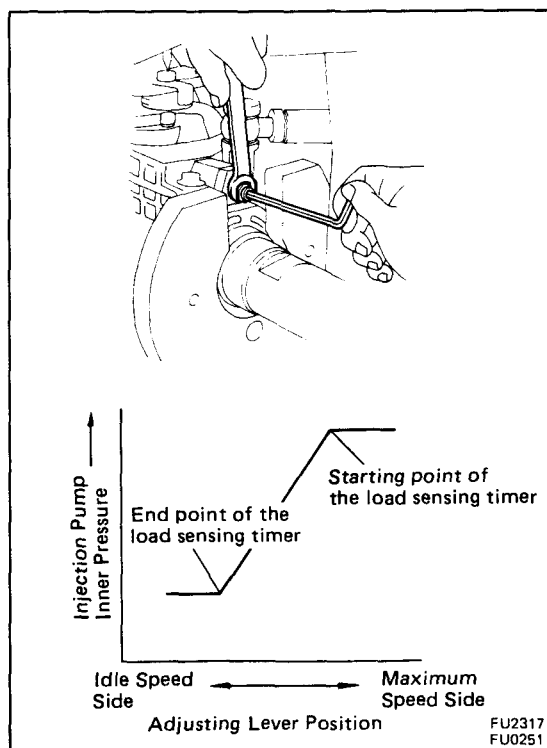

**16. (2L-T and w/o HAC)
ADJUST LOAD SENSING TIMER**

- (a) Using a 5 mm hexagonal wrench, adjust the starting and end points of the load sensing timer by turning the governor shaft.
- (b) Measure the injection volume.

Adjusting lever position	Pump rpm	No. of measuring strokes
Maximum speed side	1,200	200

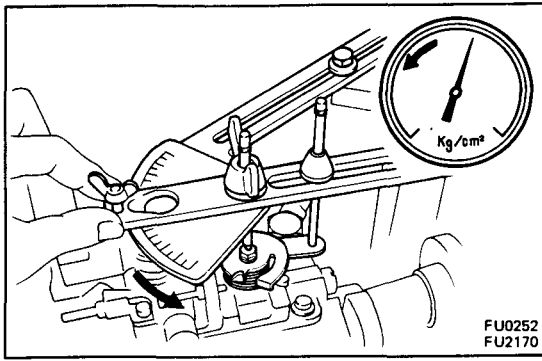

- (e) Slowly move the adjusting lever from the maximum speed side to the idle speed side, and secure it at the point where the pump inner pressure begins to drop.
- (f) Measure the injection volume at the drop point (starting point).

Item	Pump rpm	No. of measuring strokes	Injection volume mm (cu in.)
2L-T	1,200	200	Measured value at step (b) minus 0.6 (0.04) ± 0.4 (0.02)
3L	1,200	200	Measured value at step (b) minus 1.0 (0.06) ± 0.4 (0.02)

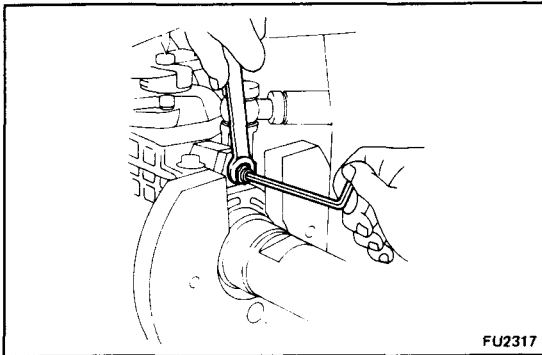

- (g) Using a 5 mm hexagonal wrench, adjust the load sensing timer by turning the governor shaft, and perform the measurement again as specified.

HINT: The injection volume will increase approx. 3 cc (0.2 cu in.) with each 1/2 turn of the governor shaft.

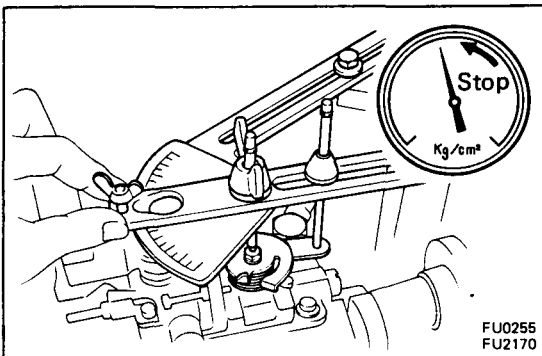

- (h) Check the end point injection volume by slowly moving the adjusting lever from the maximum speed side to the idle speed side, and secure it at the point where the pump inner pressure stops dropping.

Item	Pump rpm	No. of measuring strokes	Injection volume cc (cu in.)
2L-T	1,200	200	8.10 – 8.50 (0.49 – 0.52)
3L	Hong Kong, Singapore, Malaysia	1,200	8.12 – 8.52 (0.50 – 0.52)
	Others	1,200	8.72 – 9.12 (0.52 – 0.56)

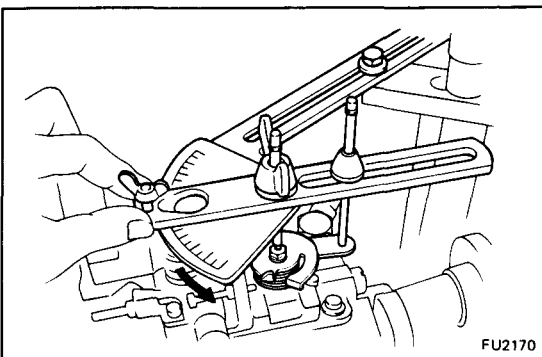

- (i) Check the timer piston fluctuation when the adjusting lever is moved from the maximum speed side to the idle speed side.

Item	Pump rpm	Timer piston fluctuation mm (in.)
2L-T	1,200	1.44 – 1.84 (0.057 – 0.072)
3L	1,200	0.62 – 1.02 (0.024 – 0.040)

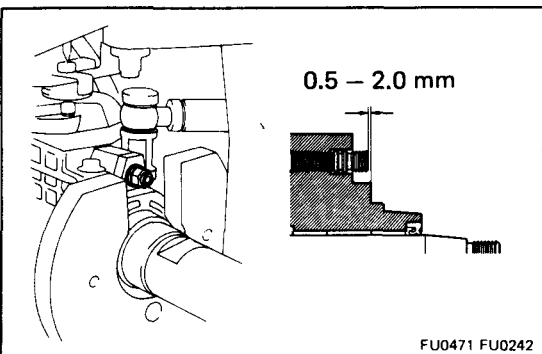

- (j) Check the protrusion of the governor shaft.
Protrusion: 0.5 – 2.0 mm (0.020 – 0.079 in.)

17. CHECK INJECTION VOLUME

- (a) (2L-T Austria)
Apply 0.68 kg/cm² (9.6 psi, 66 kPa) of pressure to the boost compensator.
- (b) (2L-T Others)
Apply 0.63 kg/cm² (9.0 psi, 62 kPa) of pressure to the boost compensator.
- (c) Measure the injection volume for each pump rpm.

Item		Adjusting lever angle position	Pump rpm	No. of measuring strokes	Injection volume cc (cu in.)	Variation limit cc (cu in.)	Remarks	
2L-T	Austria	Plus 23.5 – 33.5°	1,400	200	13.94 – 14.26 (0.85 – 0.87)	0.4 (0.02)	Basic full-load injection volume	
			100		13.60 – 18.40 (0.83 – 1.12)	1.2 (0.07)	Volume during starting	
			1,200		13.70 – 15.10 (0.84 – 0.92)	0.5 (0.03)	–	
			1,800		12.30 – 13.70 (0.75 – 0.84)	0.5 (0.03)	–	
			2,000		11.60 – 12.80 (0.71 – 0.78)	0.5 (0.03)	–	
	Others	Plus 23.5 – 33.5°	1,200	200	13.94 – 14.26 (0.85 – 0.87)	0.4 (0.02)	Basic full-load injection volume	
			100		13.60 – 18.40 (0.83 – 1.12)	1.2 (0.07)	Volume during starting	
			1,800		12.10 – 13.10 (0.74 – 0.80)	0.5 (0.03)	–	
	3L	Hong Kong, Singapore, Malaysia	Plus 23.5 – 33.5°	1,200	200	10.96 – 11.28 (0.67 – 0.69)	0.4 (0.02)	Basic full-load injection volume
				100		11.60 – 16.40 (0.71 – 1.00)	1.2 (0.07)	Volume during starting
500				9.64 – 11.04 (0.59 – 0.67)		0.5 (0.03)	–	
1,900				9.39 – 10.69 (0.57 – 0.65)		0.5 (0.03)	–	
Others		Plus 23.5 – 33.5°	1,200	200	11.56 – 11.88 (0.71 – 0.72)	0.4 (0.02)	Basic full-load injection volume	
			100		11.60 – 16.40 (0.71 – 1.00)	1.2 (0.07)	Volume during starting	
			500		10.44 – 11.44 (0.64 – 0.70)	0.5 (0.03)	–	
			2,000		10.19 – 11.09 (0.62 – 0.68)	0.5 (0.03)	–	

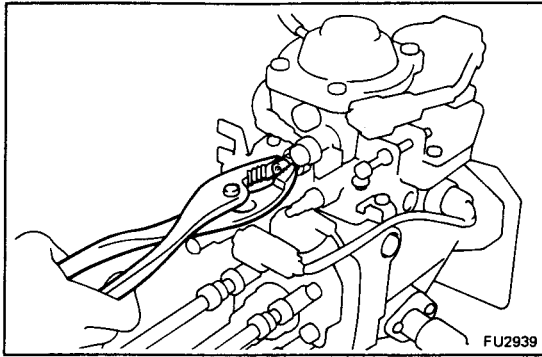

18. ADJUST IDLE SPEED

- (a) (2L-T)
Using pliers, remove the dash pot cover.

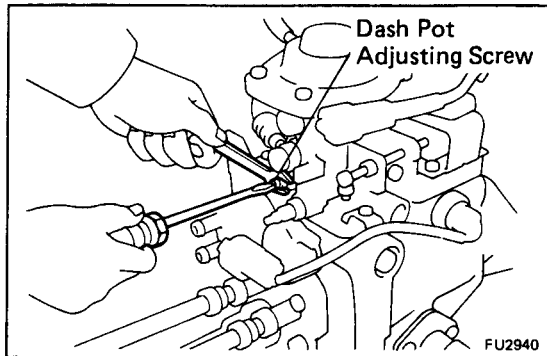

- (b) (2L-T)
Fully loosen the dash pot adjusting screw.

- (c) Measure the injection volume for each pump rpm.

Item		Adjusting lever angle position	Pump rpm	No. of measuring strokes	Injection volume cc (cu in.)	Variation limit cc (cu in.)	Remark
2L-T	Austria	Minus 13.5 – 21.5°	375	200	q = 2.4 – 2.6 (0.15 – 0.16)	–	Pre-set
			350		q plus 0.5 (0.03) or more	–	–
			450		q minus 1.1 – 2.1 (0.07 – 0.13)	–	–
	Others	Minus 13.5 – 21.5°	375	200	q = 1.5 – 2.5 (0.09 – 0.15)	–	Pre-set
			350		q plus 0.5 (0.03) or more	–	–
			450		q minus 0.7 – 1.7 (0.04 – 0.10)	–	–
3L	Minus 12.5 – 22.5°	350	200	1.8 – 2.8 (0.11 – 0.17)	0.34 (0.02)	Adjust	
		525		1.2 (0.07) or less	–	–	

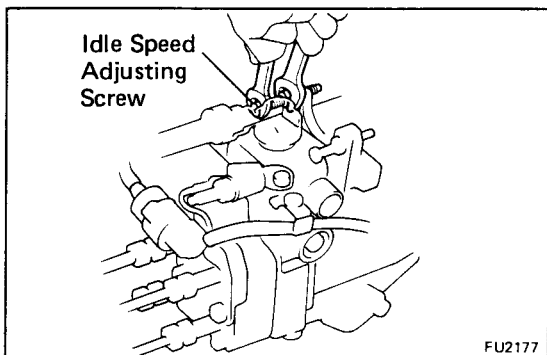

- (d) Adjust by turning the idle speed adjusting screw.

(e) (2L-T)

Set the adjusting lever to the angle for the injection volume shown below.

Item	Pump rpm	No. of measuring strokes	Injection volume cc (cu in.)
Austria	600	200	q = 0.5 – 0.7 (0.03 – 0.04)
Others	600	200	q = 0.6 – 0.8 (0.04 – 0.05)

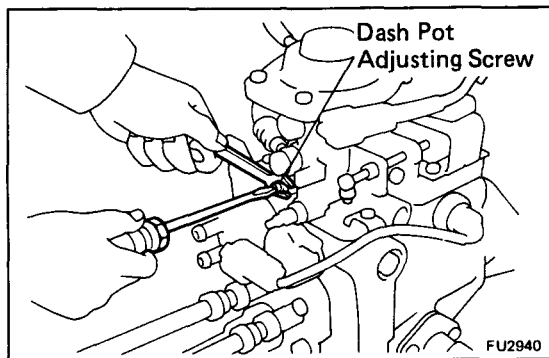

(f) (2L-T)

Adjust the injection volume with the dash pot adjusting screw.

HINT: The stroke will decrease with turn to clockwise and increase with turn to counterclockwise.

Item	Pump rpm	No. of measuring strokes	Injection volume cc (cu in.)
Austria	600	200	q plus 0.2 – 0.4 (0.01 – 0.02)
Others	600	200	q plus 0.2 – 0.4 (0.01 – 0.02)

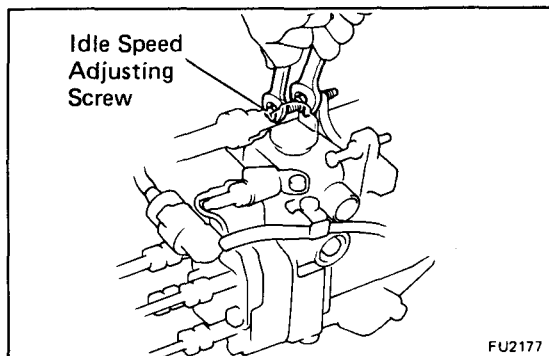

(g) (2L-T)

Readjust by turning the idle speed adjusting screw.

Item	Adjusting lever angle position	Pump rpm	Injection volume cc (cu in.)	Variation limit cc (cu in.)
Austria	Minus 13.5 – 21.5°	375	3.0 – 4.0 (0.18 – 0.24)	0.34 (0.02)
Others	Minus 13.5 – 21.5°	375	1.8 – 2.8 (0.11 – 0.17)	0.34 (0.02)

(h) (2L-T)

Install the dash pot cover.

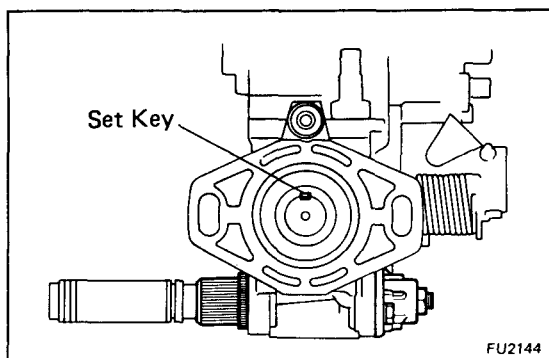

19. (2L-T)

ADJUST COLD STARTING SYSTEM

(a) Remove the overflow screw and check the fuel temperature in the fuel pump.

Fuel temperature: 15 – 35° C (59 – 95° F)

(b) Set the set key of the pump drive shaft in a vertical or horizontal position.

(c) Set the scale of the timer measuring device to zero.

(d) Check the adjusting lever opening angle and consider this angle as zero.

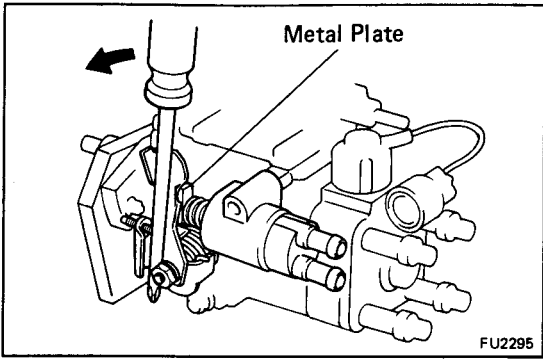

(e) Remove the metal plate between the cold starting lever and thermo wax plunger.

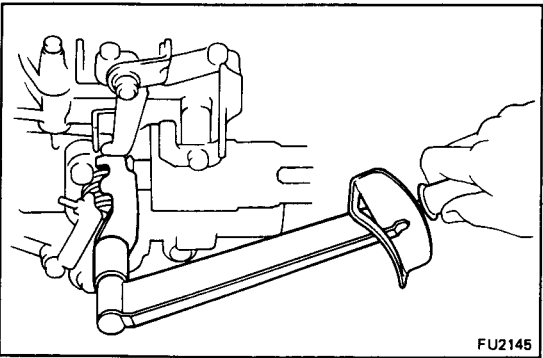

(f) Torque the cold starting lever clockwise to approx. 50 kg-cm (43 in.-lb, 4.9 N-m) and keep the lever tightened for about 10 seconds. Then release the torque.

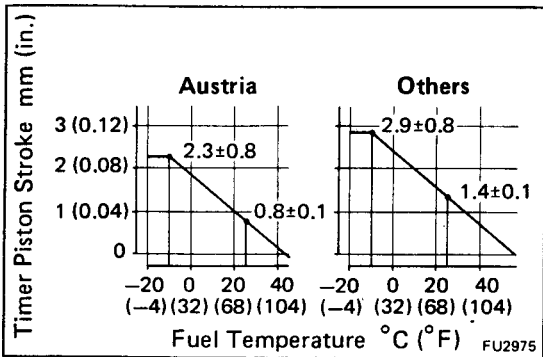

(g) Measure the timer piston stroke.

Item	Fuel temperature	Timer piston stroke mm (in.)
Austria	25°C (77°F)	0.7 – 0.9 (0.028 – 0.035)
Others	25°C (77°F)	1.3 – 1.5 (0.051 – 0.059)

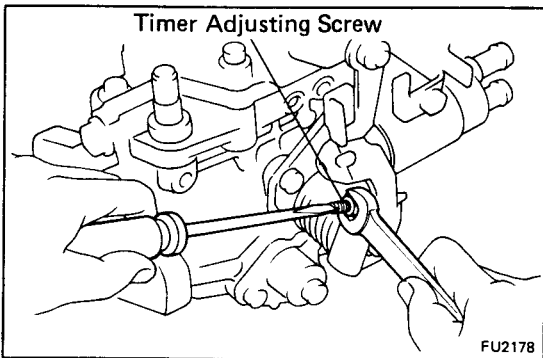

(h) Adjust by turning the timer adjusting screw.

HINT: Screw in for stroke decrease.

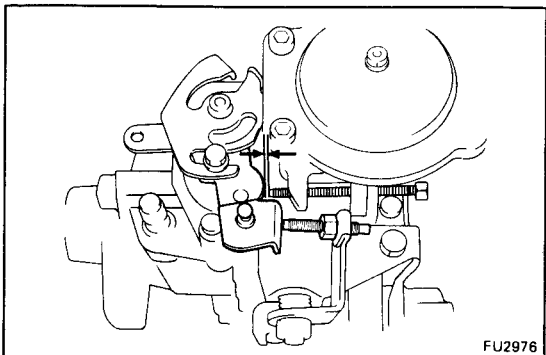

20. (2L-T)
ADJUST FAST IDLE

(a) Measure the clearance between the adjusting lever and idle speed adjusting screw.

Fuel temperature	Clearance
20°C (68°F)	2.5 mm (0.098 in.)
50°C (122°F)	0 mm (0 in.)

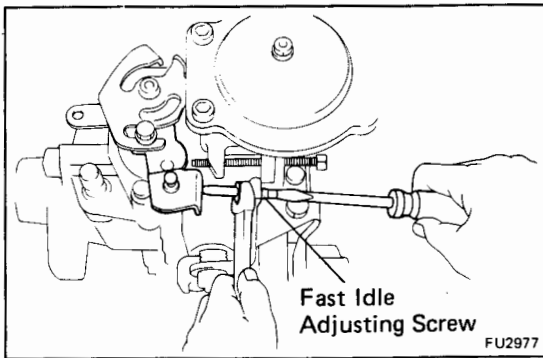

(b) Adjust by turning the fast idle adjusting screw.

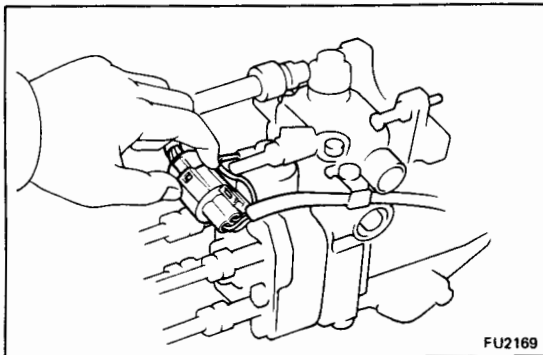

21. POST ADJUSTMENT CHECK

(a) Check that injection stops when the fuel cut solenoid harness is removed.

Pump revolution: 100 rpm

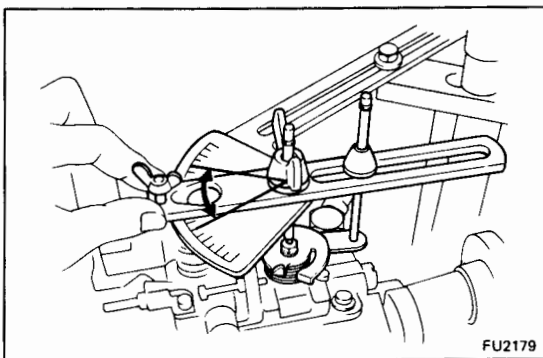

(b) Check the adjusting lever movement.

Adjusting lever angle: 2L-T 41 – 51°
3L 43 – 49°

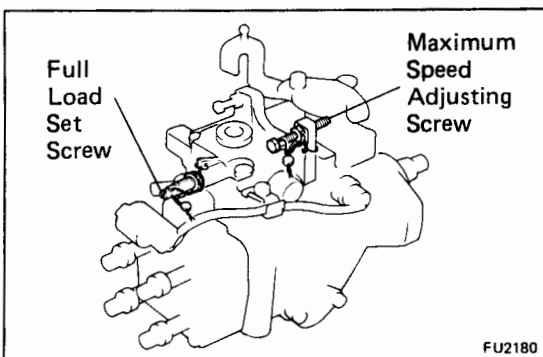

22. SEAL PARTS

Seal the maximum speed adjusting screw and full load set screws with new lead seals.

INSTALLATION OF INJECTION PUMP

(See page FU-3)

NOTICE: Do not put the injection pump (2L-T and w/ HAC) at an angle more than 45° from the horizontal.

1. INSTALL FUEL INLET AND OUTLET PIPES TO INJECTION PUMP

Torque: 250 kg-cm (18 ft-lb, 25 N-m)

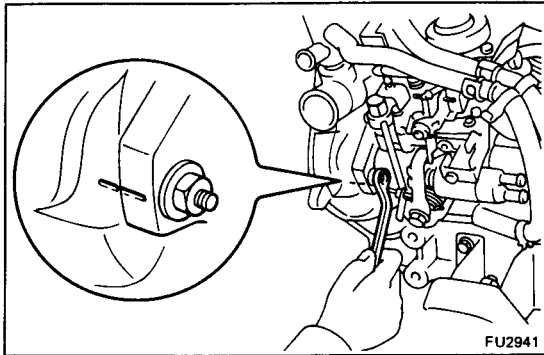

FU2941

2. INSTALL INJECTION PUMP

(a) Align the period lines (or matchmarks) of the injection pump and timing belt case.

(b) Install the two nuts holding the injection pump to the timing belt case.

Torque: 210 kg-cm (15 ft-lb, 21 N-m)

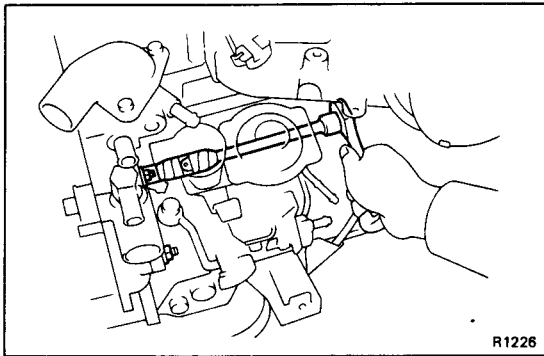

R1226

(c) Install the pump stay with the four bolts.

Torque: 185 kg-cm (13 ft-lb, 18 N-m)

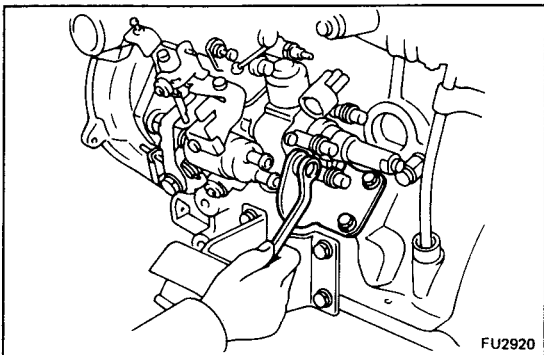
3. CHECK INJECTION TIMING (See page EM-24 or 25)

FU2920

4. INSTALL INJECTION PIPES

(a) Place the two lower clamps on the intake manifold.

(b) Install the four injection pipes.

Torque: 250 kg-cm (18 ft-lb, 25 N-m)

NOTICE: On vehicles with the PIJ (2L-T Austria), do not interfere with the PIJ actuator with the spanner. Use a 14 mm spanner when tightening the union nut of No. 2 injection pipe.

(c) Secure the injection pipes with the two upper clamps and bolts.

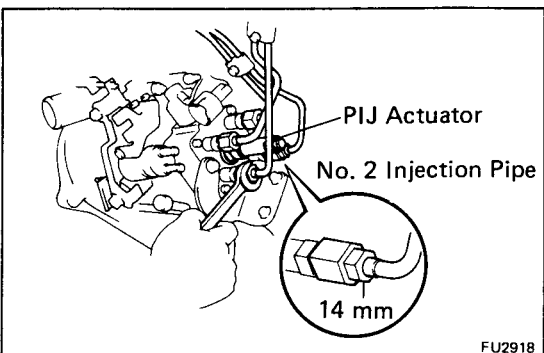

FU2918

5. CONNECT FUEL HOSES TO INJECTION PUMP
6. CONNECT INJECTION PUMP CONNECTOR(S)
7. (2L-T)
CONNECT WATER BY-PASS HOSES TO THERMO WAX
8. (w/ A/C)
CONNECT A/C IDLE-UP VACUUM HOSE
9. (2L-T)
CONNECT BOOST COMPENSATOR HOSE
10. INSTALL ACCELERATOR LINKAGE
11. INSTALL INJECTION PUMP DRIVE PULLEY
Torque: 650 kg-cm (47 ft-lb, 64 N·m)
12. SET NO. 1 CYLINDER TO TDC/COMPRESSION
13. INSTALL TIMING BELT
14. CHECK VALVE TIMING
15. INSTALL NO. 1 TIMING BELT COVER
16. INSTALL CRANKSHAFT PULLEY
Torque: 1,700 kg-cm (123 ft-lb, 167 N·m)
17. INSTALL WATER PUMP PULLEY, FLUID COUPLING
AND FAN
18. (2L-T)
INSTALL TURBO WATER HOSE
19. (2L-T)
FILL WITH ENGINE COOLANT (See page CO-5)
20. START ENGINE AND CHECK FOR FUEL LEAKS
21. CHECK IDLE SPEED AND MAXIMUM SPEED
(See page EM-27)

COOLING SYSTEM

REFER TO 2L, 3L ENGINE REPAIR MANUAL
(Pub. No. RM123E)

NOTE: The following pages contain only the points which differ from the above listed manual.

	Page
DESCRIPTION	CO-2
TROUBLESHOOTING	CO-4
CHECK AND REPLACEMENT OF ENGINE COOLANT	CO-4
THERMOSTAT (2L-T)	CO-6

CO

DESCRIPTION

This engine utilizes a pressurized water forced circulation cooling system which includes a thermostat equipped with a by-pass valve mounted on the inlet side.

2L-T

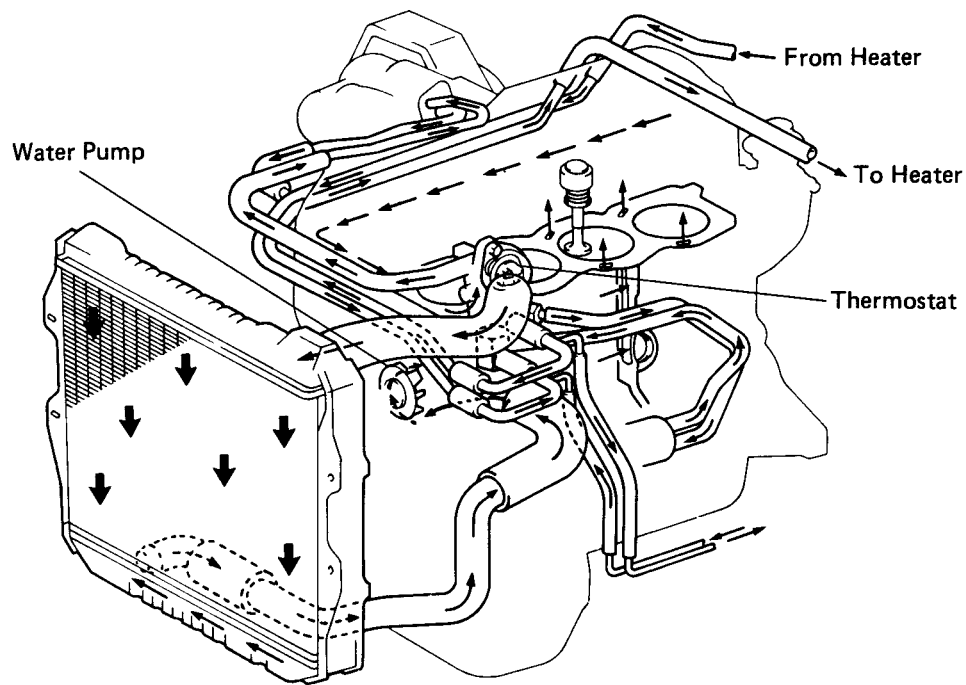

3L

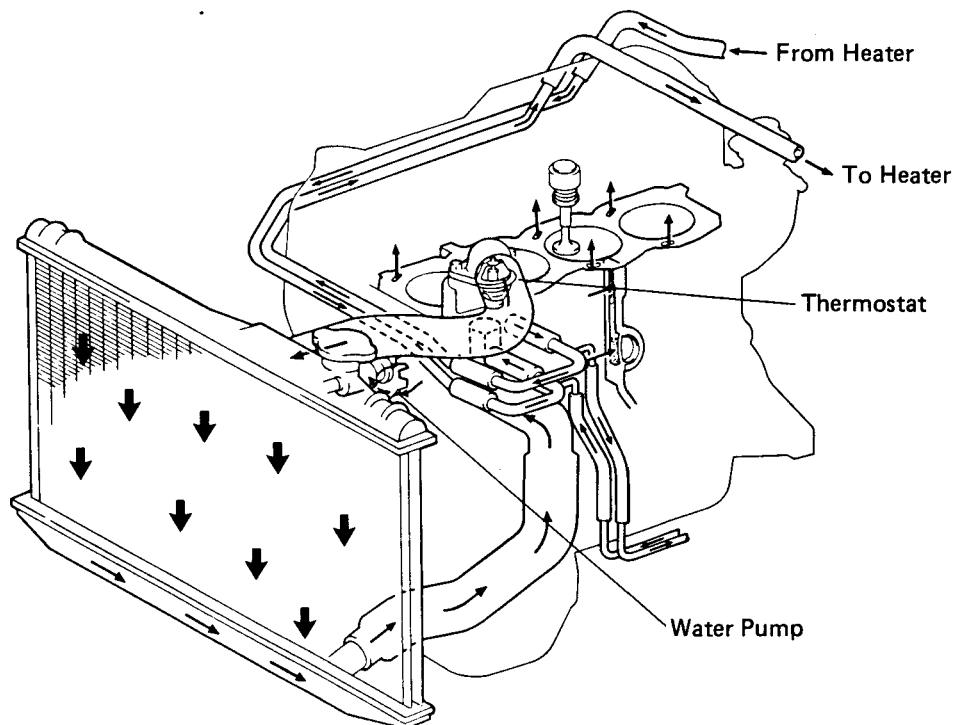

The cooling system is composed of the water jacket (inside the cylinder block and cylinder head), radiator, water pump, thermostat, cooling fan, hoses and other components. Coolant which is heated in the water jacket is pumped to the radiator, where it is cooled by the cooling fan and the vehicle windstream. Coolant which has been cooled is then sent back to the engine by the water pump, where it cools the engine. The water jacket is a network of channels in the shell of the cylinder block and cylinder head through which coolant passes. It is designed to provide adequate cooling of the cylinders and combustion chambers which become the hottest during engine operation.

RADIATOR

The radiator performs the function of cooling the coolant which has passed through the water jacket and become hot, and it is mounted in the front of the vehicle. The radiator consists of an upper tank and lower tank, and a core which connects the two tanks. The upper tank contains an inlet for coolant from the water jacket and a filler inlet. It also has a hose through which excess coolant or steam can flow. The lower tank has an outlet and drain cock for the coolant. The core contains many tubes and cooling fins through which coolant flows from the upper tank to the lower tank so that coolant has been heated up as it passes through the water jacket is cooled here by the air sucked through the radiator by the cooling fan, as well as by the wind generated by the vehicle's travel. Models with an automatic transmission include an automatic transmissions fluid cooler built into the lower tank of the radiator.

RADIATOR CAP

The radiator cap is a pressure type cap which seals the radiator, resulting in pressurization of the radiator as the coolant expands. The pressurization prevents the coolant from boiling even when the coolant temperature exceeds 100°C (212°F). A relief valve (pressurization valve) and a vacuum valve (negative pressure valve) are built into the radiator cap. When the pressure generated inside the cooling system exceeds the limit (coolant temperature: 110 – 120°C, 230 – 248°F, pressure; 0.3 – 1.0 kg/cm², 4.3 – 14.2 psi, 29.4 – 98.1 kPa) the relief valve is opened by the pressure and lets steam escape through the overflow pipe. The vacuum valve opens to allow atmospheric air to enter to alleviate the vacuum which develops in the cooling system after the engine is stopped and the coolant temperature drops. The valve's opening allows the pressure in the cooling system to return to the reservoir tank.

RESERVOIR TANK

The reservoir tank is used to catch coolant which overflows the cooling system as a result of volumetric expansion when the coolant is heated. When the coolant temperature drops, the coolant in the reservoir tank returns to the radiator, thus keeping the radiator full at all times and avoiding needless coolant loss. To find out if the coolant needs to be replenished, check the reservoir tank level.

WATER PUMP

The water pump is used for forced circulation of coolant through the cooling system. It is mounted on the front of the cylinder block and driven by a drive belt.

THERMOSTAT

The thermostat has a wax type by-pass valve and is mounted in the water outlet housing. The thermostat is a type of automatic valve operated by fluctuations in the coolant temperature. This valve closes when the coolant temperature drops, preventing the circulation of coolant through the radiator and thus permitting the engine to warm up rapidly. The valve opens when the coolant temperature has risen, allowing the circulation of coolant. Wax inside the thermostat expands when heated and contracts when cooled. Heating the wax thus generates pressure which overpowers the force of the spring which keeps the valve closed, thus opening the valve. When the wax cools, its contraction causes the force of the spring to take effect once more, closing the valve. The thermostat in this engine operates at a temperature of 88°C (191°F).

TROUBLESHOOTING

Problem	Possible cause	Remedy	Page
Engine overheats	Fan belt loose or missing	Adjust or replace belts	CH-3
	Dirt, leaves or insects on radiator or condenser	Clean radiator or condenser	
	Hoses, water pump, thermostat housing, radiator, heater, core plugs or head gasket leakage	Repair as necessary	
	Thermostat faulty	Check thermostat	CO-6
	Injection timing retarded	Adjust timing	EM-24 or 25
	Fluid coupling faulty	Replace fluid coupling	
	Radiator hose plugged or rotten	Replace hose	
	Water pump faulty	Replace water pump	
	Radiator plugged or cap faulty	Check radiator	
Cylinder head or block cracked or plugged	Repair as necessary		

HINT: Removal of the thermostat would have an adverse effect, causing a lowering of cooling efficiency. Do not remove the thermostat, even if the engine tends to overheat.

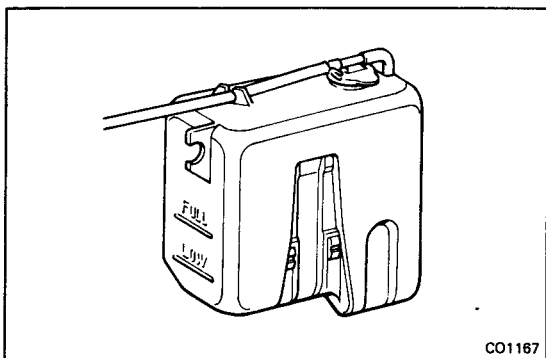

CHECK AND REPLACEMENT OF ENGINE COOLANT

1. CHECK ENGINE COOLANT LEVEL AT RESERVOIR TANK

The coolant level should be between the "LOW" and "FULL" lines.

If low, check for leaks and add coolant up to the "FULL" line.

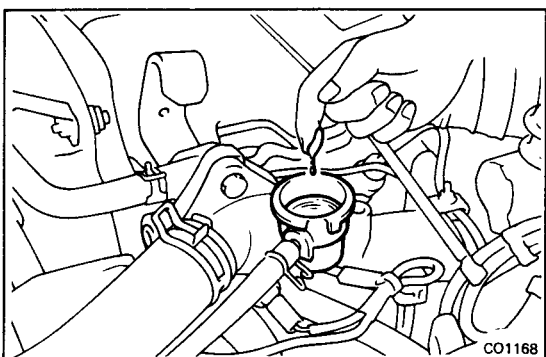

2. CHECK ENGINE COOLANT QUALITY

There should not be any excessive deposits of rust or scales around the radiator cap or radiator filler hole, and the coolant should be free from oil.

If excessively dirty, replace the coolant.

3. REPLACE ENGINE COOLANT

(a) Remove the radiator cap.

CAUTION: To avoid the danger of being burned, do not remove it while the engine and radiator are still hot, as fluid and steam can be blown out under pressure.

(b) Drain the coolant from the radiator and engine drain cocks.

(c) Close the drain cocks.

Torque (Engine drain cock):
300 kg-cm (22 ft-lb, 29 N-m)

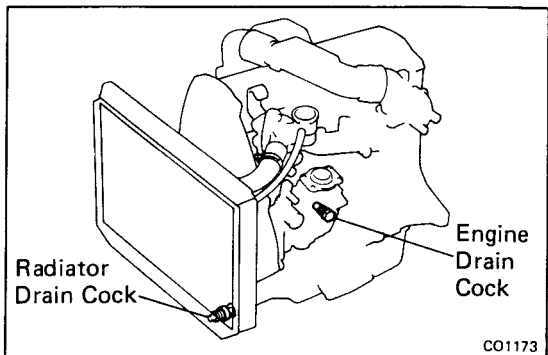

(d) Fill the system with coolant.

Use a good brand of ethylene-glycol or TOYOTA radiator conditioner or equivalent anticorrosive, mixed according to the manufacturer's directions.

Ethylene-glycol type: This type has an antifreeze and anticorrosive effect.

TOYOTA radiator conditioner: This has only an anticorrosive effect.

NOTICE:

- Do not use alcohol type coolant.
- The coolant should be mixed with demineralized water or distilled water.

Capacity (w/o Heater):

LJ		10.0 liters (10.6 US qts, 8.8 Imp. qts)
LN	2L-T	8.2 liters (8.7 US qts, 7.2 Imp. qts)
	3L	8.1 liters (8.6 US qts, 7.1 Imp. qts)

Capacity (w/ Heater):

LJ		10.9 liters (11.5 US qts, 9.6 Imp. qts)
LN	2L-T	9.1 liters (9.6 US qts, 8.8 Imp. qts)
	3L	9.0 liters (9.5 US qts, 7.9 Imp. qts)

Capacity (w/ Front and rear heaters):

LJ	2L-T	11.5 liters (12.2 US qts, 10.1 Imp. qts)
LN	2L-T	9.4 liters (9.9 US qts, 8.3 Imp. qts)
	3L	9.3 liters (9.8 US qts, 8.2 Imp. qts)

(e) Reinstall the radiator cap.

(f) Warm up the engine and check for leaks.

(g) Recheck the coolant level and refill as necessary.

THERMOSTAT (2L-T)

REMOVAL OF THERMOSTAT

1. DRAIN ENGINE COOLANT (See page CO-4)

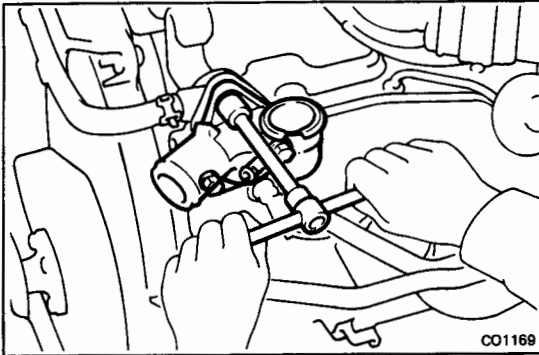

2. REMOVE WATER OUTLET

Remove the three bolts and water outlet from the water outlet housing.

3. REMOVE THERMOSTAT

INSPECTION OF THERMOSTAT

INSPECT THERMOSTAT

HINT: The thermostat is numbered with the valve opening temperature.

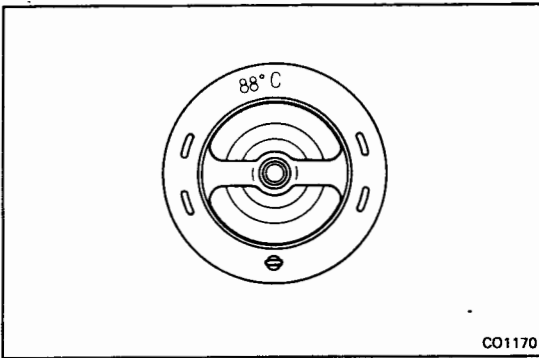

- (a) Immerse the thermostat in water and gradually heat the water.

- (b) Check the valve opening temperature.

Valve opening temperature: 86 – 90°C (187 – 194°F)

If the valve opening temperature is not as specified, replace the thermostat.

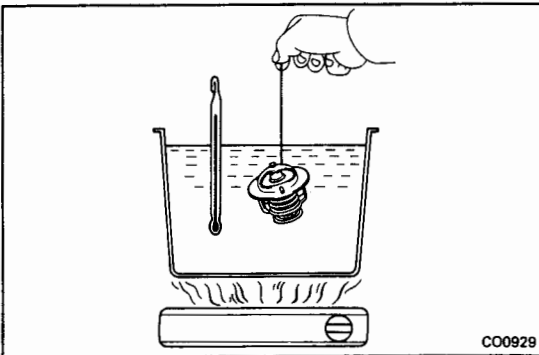

- (c) Check the valve lift.

Valve lift: 8 mm (0.31 in.) or more at 100°C (212°F)

If the valve lift is not as specified, replace the thermostat.

- (d) Check that the valve spring is tight when the thermostat is fully closed.

If necessary, replace the thermostat.

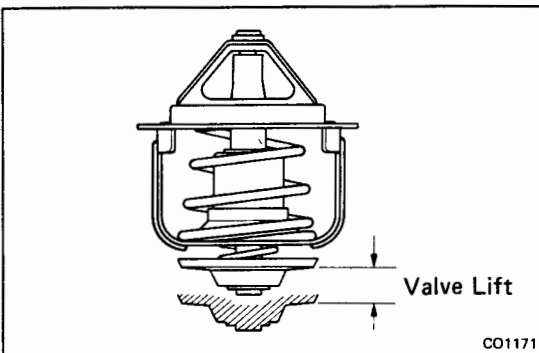

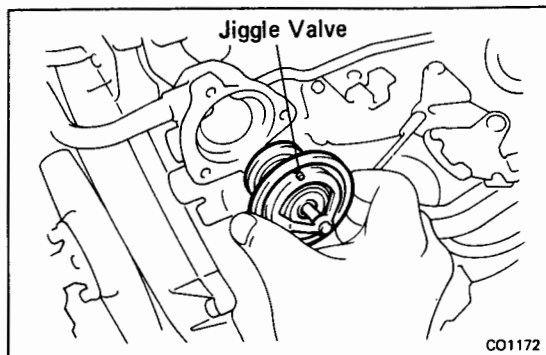

INSTALLATION OF THERMOSTAT

1. PLACE THERMOSTAT IN WATER OUTLET HOUSING
 - (a) Install a new gasket to the thermostat.
 - (b) Install the thermostat with the jiggle valve upward.

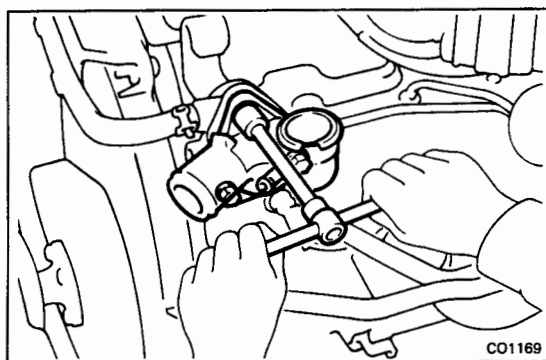

2. INSTALL WATER OUTLET TO WATER OUTLET HOUSING

Install the water outlet with the three bolts.

Torque: 195 kg-cm (14 ft-lb, 19 N-m)

3. FILL WITH ENGINE COOLANT (See page CO-5)
4. START ENGINE AND CHECK FOR LEAKS

LUBRICATION SYSTEM

REFER TO 2L, 3L ENGINE REPAIR MANUAL
(Pub. No. RM123E)

NOTE: The following pages contain only the points which differ from the above listed manual.

	Page
DESCRIPTION	LU-2
OIL PRESSURE CHECK	LU-4
REPLACEMENT OF ENGINE OIL AND OIL FILTER	LU-5
OIL COOLER AND RELIEF VALVES (2L-T)	LU-7

LU

DESCRIPTION

A fully pressurized, fully filtered lubrication system has been adopted for this engine.

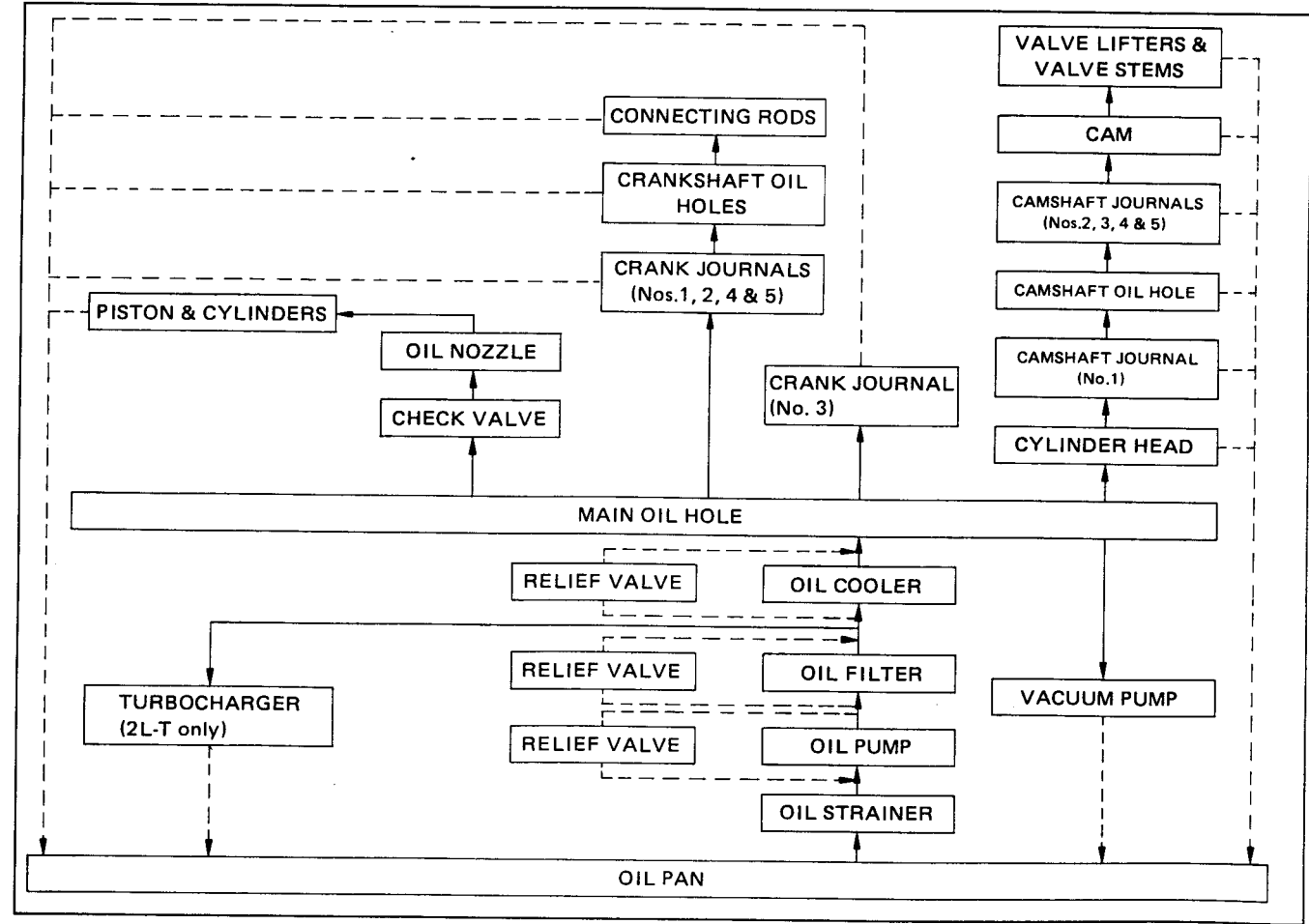
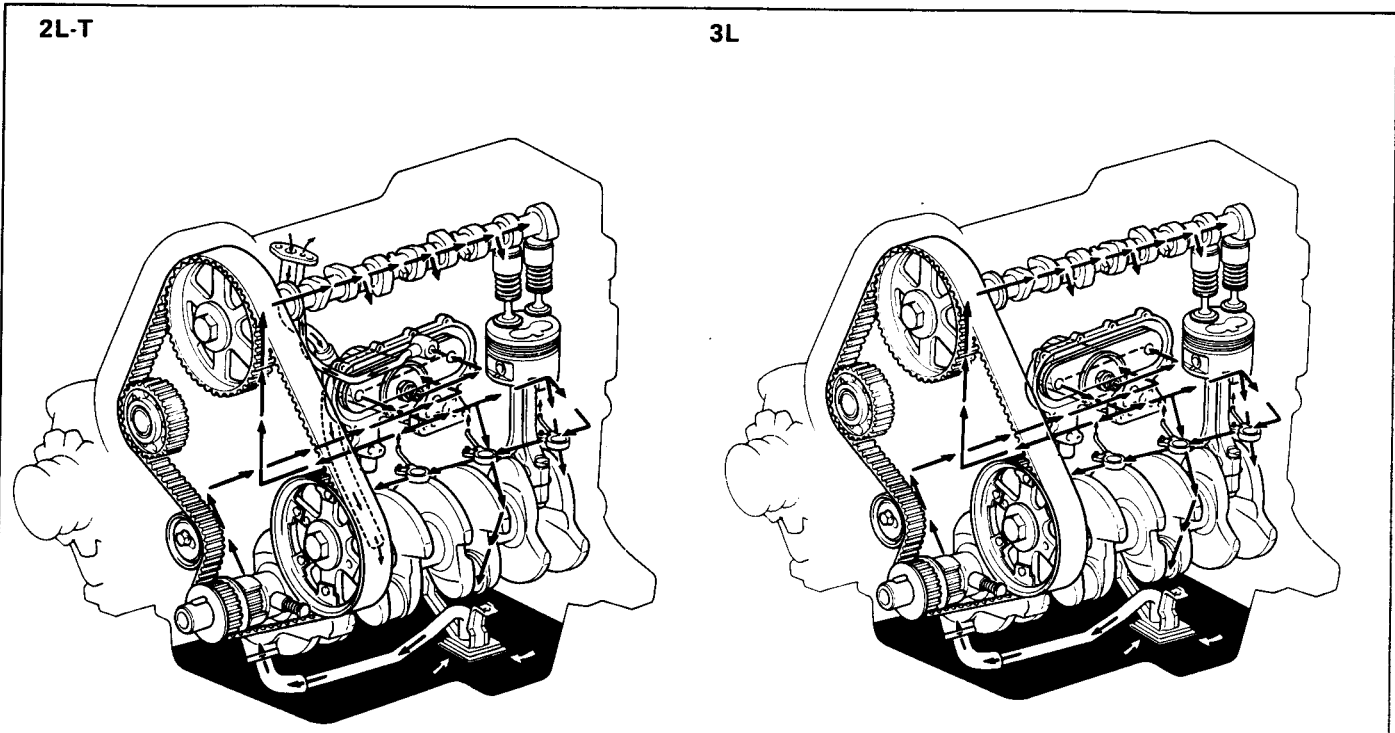

A pressure feeding lubrication system has been adopted to supply oil to the moving parts of this engine. The lubrication system consists of an oil pan, oil pump, oil filter and other external parts which supply oil to the moving parts in the engine block. The oil circuit is shown in the illustration at the top of the previous page. Oil from the oil pan is pumped up by the oil pump. After it passes through the oil filter, it is fed through the various oil holes in the crankshaft and cylinder block. After passing through the cylinder block and performing its lubricating function, the oil is returned by gravity to the oil pan. A dipstick on the center left side of the cylinder block is provided to check the oil level.

OIL PUMP

The oil pump pumps up oil from the oil pan and sends it under pressure to the various parts of the engine. An oil strainer is mounted in front of the inlet to the oil pump to remove impurities. The oil pump itself is a trochoid type pump, which uses a drive rotor and driven rotor inside the pump body. When the drive rotor rotates, the driven rotor rotates in the same direction. The axis of the drive rotor shaft is different from the center of the driven rotor, so when both rotors rotate, the space between the two rotors changes. Oil is drawn in when the space widens and is discharged when the space becomes narrow.

OIL PRESSURE REGULATOR (RELIEF VALVE)

At high engine speeds, the oil pump supplies more oil to each part that is necessary. For this reason, an oil pressure regulator which works to prevent oversupply of oil is installed on the oil pump. During normal oil supply, a coil spring and valve keep the by-pass closed, but when too much oil is being supplied, the pressure becomes extremely high, overpowering the force of the spring and opening the valves. This allows the excess oil to flow through the valve and return to the inlet of the oil pump.

OIL FILTER

There are two types of oil filter, a full flow type and a by-pass element type. A full flow type has a relief valve built into the paper filter element. Particles of metal from wear, airborne dirt, carbon and other impurities can get in the oil during use and could cause accelerated wear or seizing if allowed to circulate through the engine. The oil filter, integrated into the oil line, removes these impurities as the oil passes through it. The filter is mounted outside the engine to simplify replacement of the filter element. A relief valve is also included ahead of the filter element to relieve the high oil pressure in case the filter element becomes clogged with impurities. The relief valve opens when the oil pressure overpowers the force of the spring. Oil passing through the relief valve by-passes the oil filter and flows directly into the main oil hole in the engine.

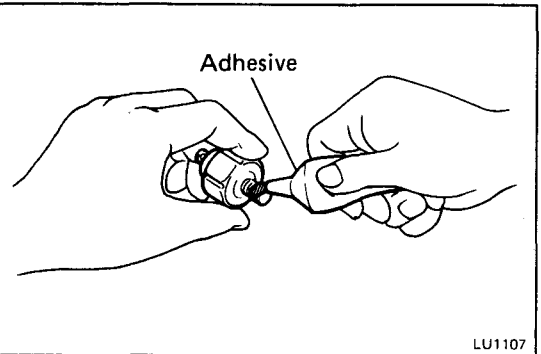
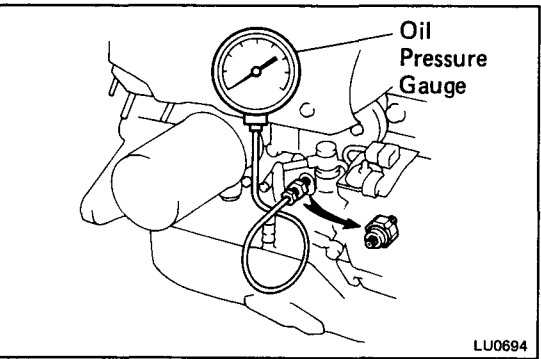
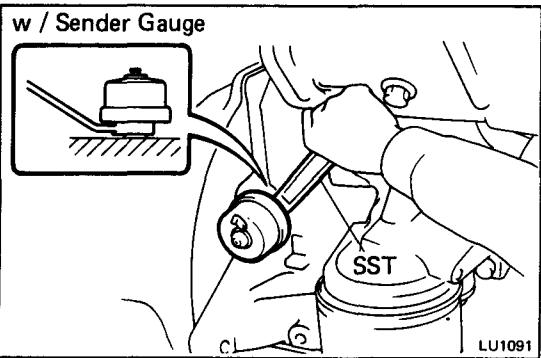
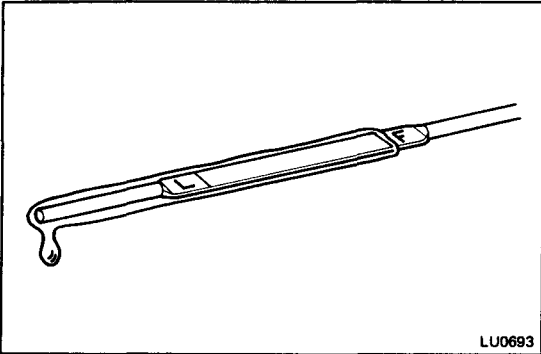
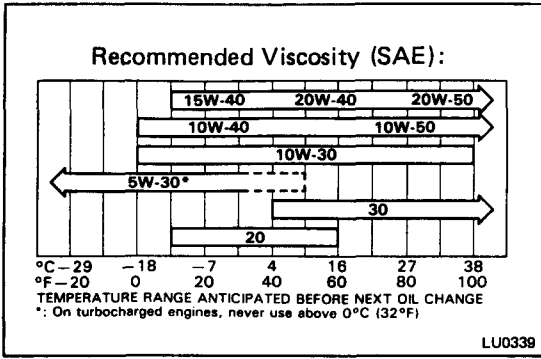

OIL PRESSURE CHECK

1. CHECK ENGINE OIL QUALITY

Check the oil for deterioration, entry of water, discoloring or thinning.

If the quality is poor, replace the oil.

(2L-T)

- Use API grade CD or better and recommended viscosity oil.

(3L)

- Use API grade CC, CD or better and recommended viscosity oil.

2. CHECK ENGINE OIL LEVEL

The oil level should be between the "L" and "F" marks on the dipstick.

If low, check for leakage and add oil up to "F" mark.

NOTICE: Do not fill with engine oil above the "F" mark.

3. REMOVE OIL PRESSURE SWITCH OR SENDER GAUGE

HINT (w/ Sender gauge): Use SST.
SST 09027-12140

4. INSTALL OIL PRESSURE GAUGE

5. WARM UP ENGINE

Allow the engine to reach normal operating temperature.

6. CHECK OIL PRESSURE

Oil pressure:

At idling 0.3 kg/cm² (4.3 psi, 29 kPa)
or more

At 3,000 rpm 3.0 – 5.5 kg/cm²
(43 – 78 psi, 294 – 539 kPa)

7. REMOVE OIL PRESSURE GAUGE

8. REINSTALL OIL PRESSURE SWITCH OR SENDER GAUGE

Apply adhesive to two or three threads.

Adhesive: Part No. 08833-00080, THREE BOND 1344, LOCTITE 242 or equivalent

9. START ENGINE AND CHECK FOR LEAKS

REPLACEMENT OF ENGINE OIL AND OIL FILTER

CAUTION:

- Prolonged and repeated contact with mineral oil will result in the removal of natural fats from the skin, leading to dryness, irritation and dermatitis. In addition, used engine oil contains potentially harmful contaminants which may cause skin cancer. Adequate means of skin protection and washing facilities should be provided.
- Care should be taken, therefore, when changing engine oil, to minimize the frequency and length of time your skin is exposed to used engine oil. Protective clothing and gloves, that cannot be penetrated by oil, should be worn. The skin should be thoroughly washed with soap and water, or use waterless hand cleaner, to remove any used engine oil. Do not use gasoline, thinners, or solvents.
- In order to preserve the environment, used oil and used oil filters must be disposed of only at designated disposal sites.

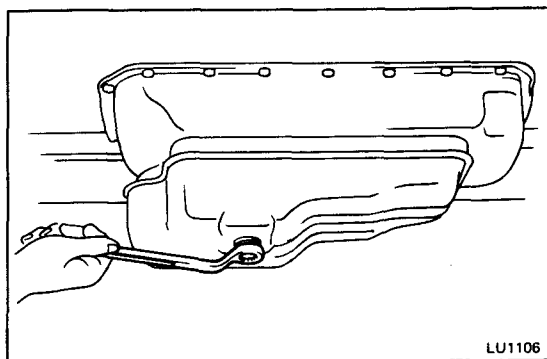

1. DRAIN ENGINE OIL

- Remove the oil filler cap.
- Remove the oil drain plug, and drain the oil into a container.

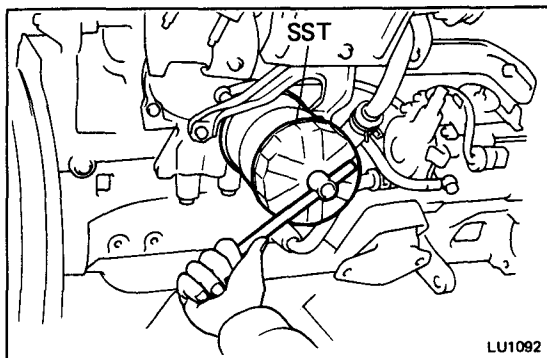

2. REPLACE OIL FILTER

- Using SST, remove the oil filter.

SST 09228-10001 (w/ By-pass element type)
09228-40011 (Full flow type)

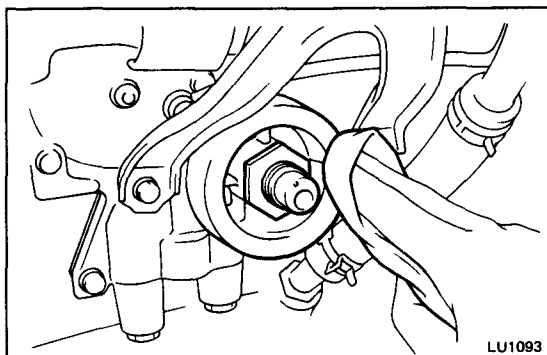

- Clean and check the oil filter installation surface.

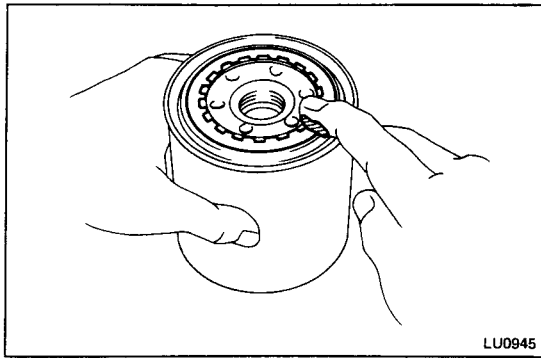

(c) Apply clean engine oil to the gasket of a new oil filter.

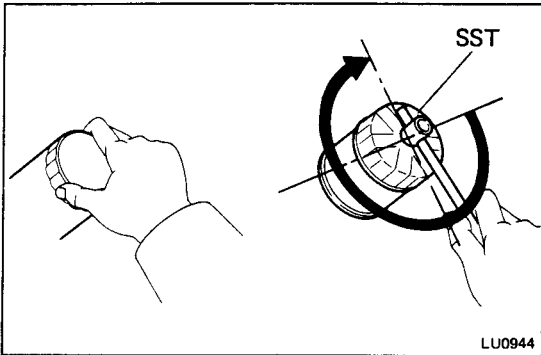

(d) Lightly screw the oil filter into place, and tighten it until the gasket contacts the seat.

(e) Using SST, tighten it additional 3/4 turn.

SST 09228-10001 (w/ By-pass element type)
09228-44011 (Full flow type)

3. FILL WITH ENGINE OIL

(a) Clean and install the oil drain plug with a new gasket.

Torque: 400 kg-cm (29 ft-lb, 39 N-m)

(b) Fill with new engine oil (API grade CC (3L only), CD or better and recommended viscosity oil).

Capacity:

liters (US qts, Imp. qts)

Item		w/ Oil filter change	w/o Oil filter change	Dri fill
LJ	2L-T	6.7 (7.1, 5.9)	5.7 (6.0, 5.0)	7.4 (7.8, 6.5)
	3L	6.7 (7.1, 5.9)	5.7 (6.0, 5.0)	7.4 (7.8, 6.5)
LN	2L-T	6.8 (7.2, 6.0)	5.8 (6.1, 5.1)	7.5 (7.9, 6.6)
	3L	5.8 (6.1, 5.1)	4.8 (5.1, 4.2)	6.5 (6.9, 5.7)

(c) Reinstall the oil filler cap.

4. START ENGINE AND CHECK FOR LEAKS

5. RECHECK ENGINE OIL LEVEL (See page LU-4)

OIL COOLER AND RELIEF VALVES (2L-T) COMPONENTS

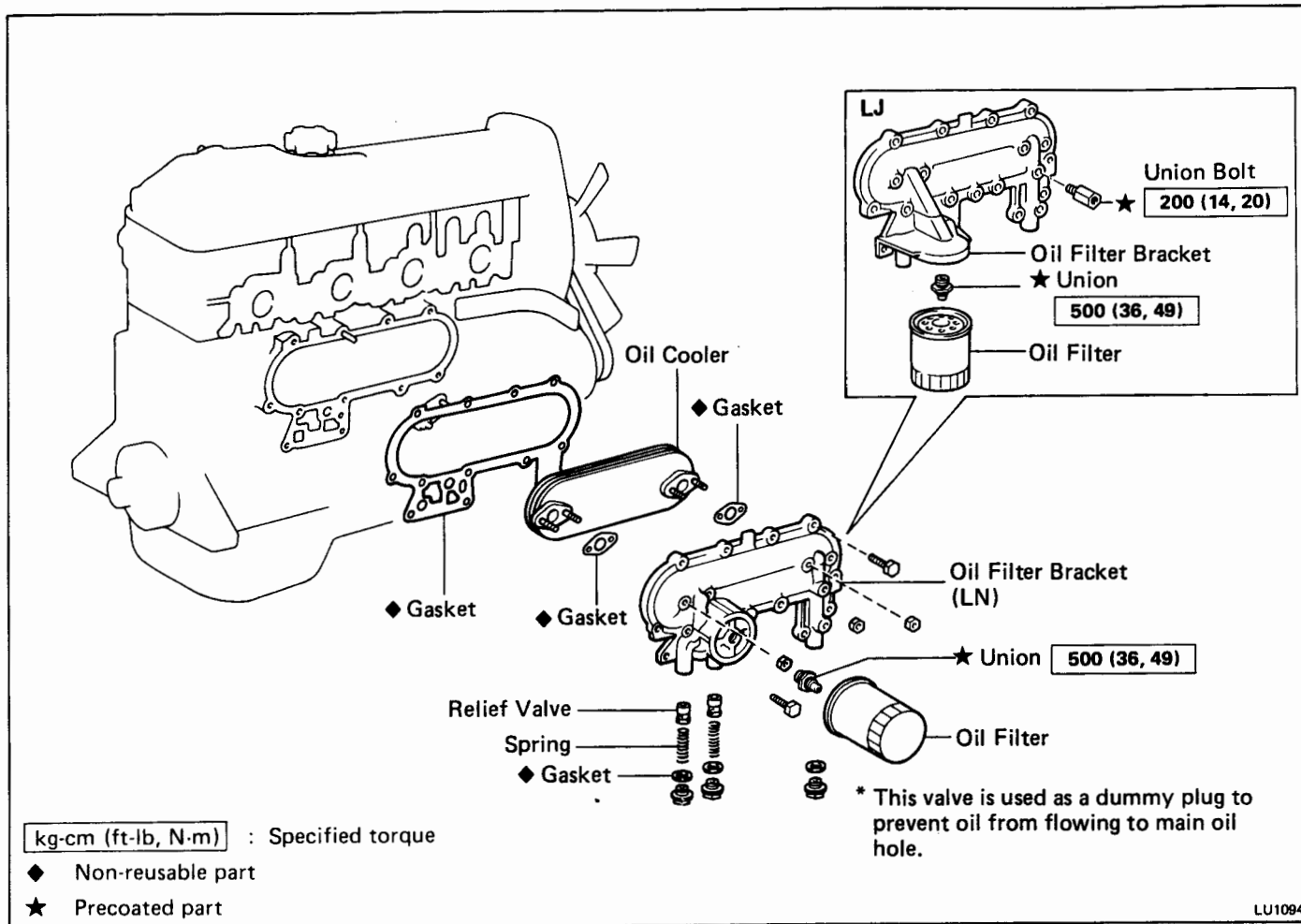

REMOVAL OF OIL COOLER AND RELIEF VALVES

1. DRAIN ENGINE COOLANT (See page CO-4)
2. REMOVE TURBOCHARGER
(See steps 2 to 7 on pages TC-10 and 11)
3. (Austria)
REMOVE EGR VALVE, PIPE, VALVE ADAPTOR AND CONTROL VALVE ASSEMBLY
(See step 11 on page EM-37)
4. REMOVE EXHAUST MANIFOLD
(See step 13 on page EM-38)
5. REMOVE ALTERNATOR
6. (LJ)
REMOVE UNION BOLT
7. REMOVE OIL FILTER (See page LU-5)

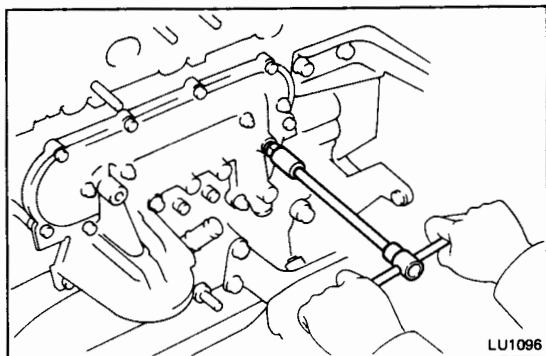

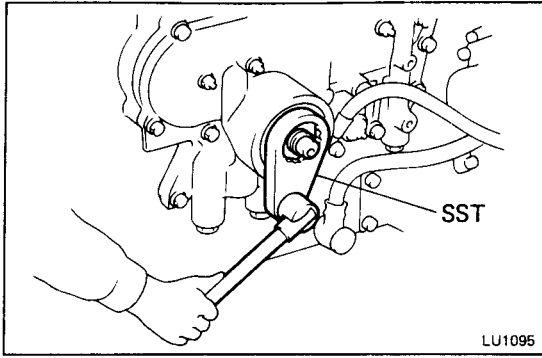
**8. REMOVE UNION**

Using SST, remove the union.
SST 09326-20011

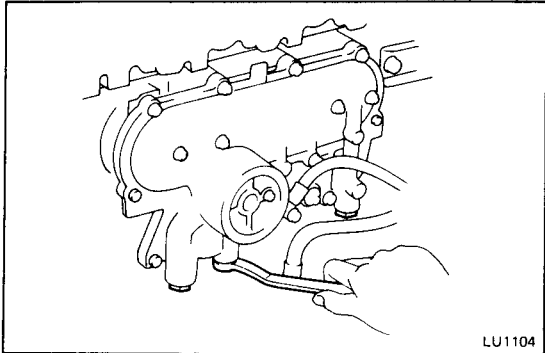
**9. REMOVE RELIEF VALVES**

Remove the plug, gasket, spring and relief valve. Remove the two relief valves.

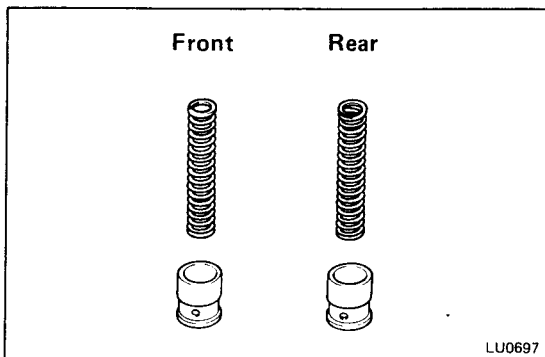

HINT: Arrange the spring and relief valves in correct order.

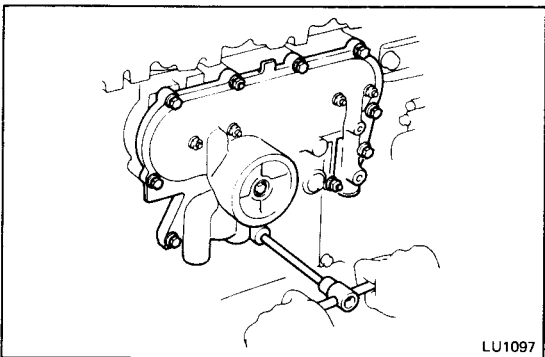
**10. REMOVE OIL COOLER AND OIL FILTER BRACKET ASSEMBLY**

Remove the nine bolts (LN) or ten bolts (LJ), two nuts, the oil cooler, filter bracket assembly and gasket.

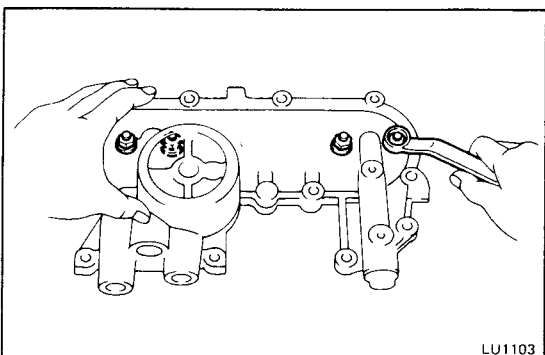
**11. SEPARATE OIL COOLER AND OIL FILTER BRACKET**

Remove the four nuts, the oil cooler and two gaskets from the filter bracket.

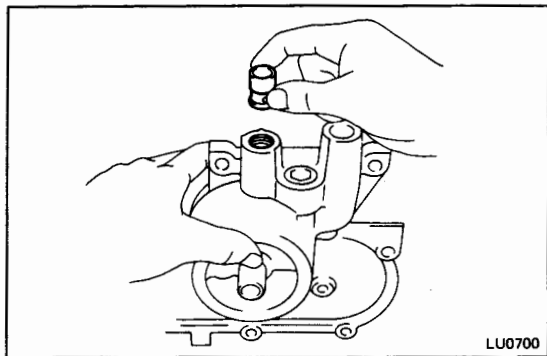

LU0700

INSPECTION OF OIL COOLER AND RELIEF VALVES

1. INSPECT RELIEF VALVE

Coat the valve with engine oil and check that it falls smoothly into the oil filter bracket by its own weight.

If not, replace the relief valve. If necessary, replace the oil filter bracket.

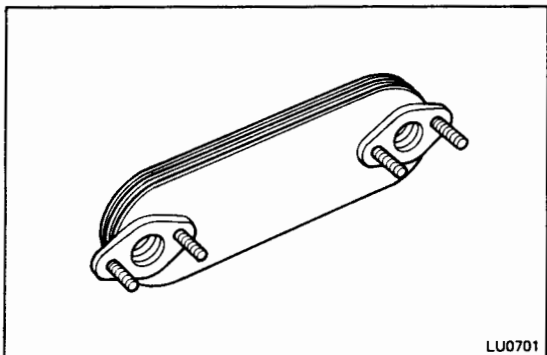

LU0701

2. INSPECT OIL COOLER

Check the oil cooler for damage or clogging.

If necessary, replace the oil cooler.

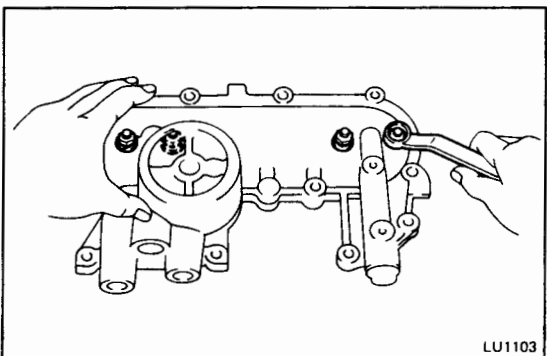

LU1103

INSTALLATION OF OIL COOLER AND RELIEF VALVES

(See page LU-7)

1. ASSEMBLE OIL COOLER AND OIL FILTER BRACKET

Install new gaskets and the oil cooler to the filter bracket with the four nuts.

Torque: 145 kg-cm (10 ft-lb, 14 N-m)

2. INSTALL OIL COOLER AND OIL FILTER BRACKET ASSEMBLY

Install a new gasket, the oil cooler and filter bracket assembly with the nine bolts (LN) or ten bolts (LJ) and two nuts.

Torque: Bolt 195 kg-cm (14 ft-lb, 19 N.m)

Nut 210 kg-cm (15 ft-lb, 21 N.m)

HINT: The bolt lengths for bolt types B and C shown in the illustration are:

B 35 mm (1.38 in.)

C 25 mm (0.98 in.)

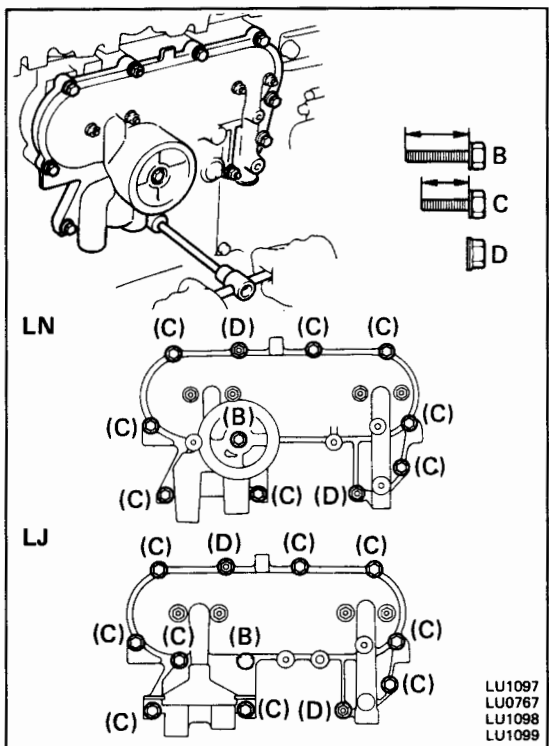

LU1097
LU0767
LU1098
LU1099

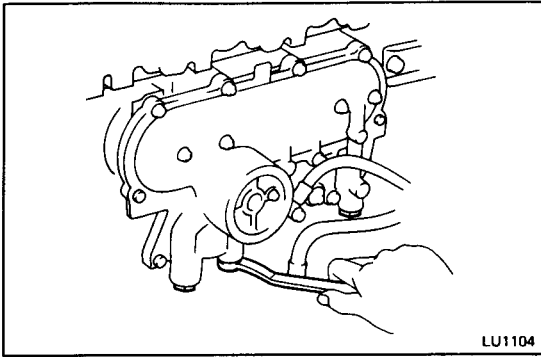

3. INSTALL RELIEF VALVES

Install the relief valve, spring and a new gasket with the plug. Install the two relief valves.

Torque: 370 kg-cm (27 ft-lb, 36 N-m)

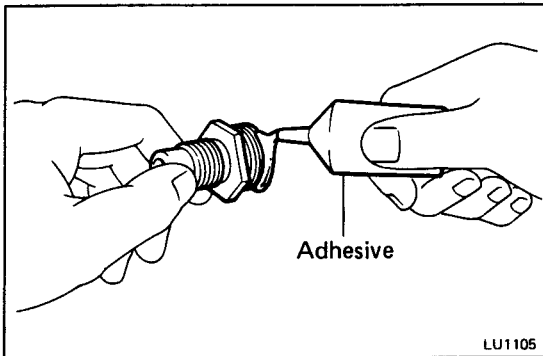

4. INSTALL UNION

(a) Apply adhesive to two or three threads (oil cooler side of the union).

Adhesive: Part No. 08833-00070, THREE BOND 1324 or equivalent

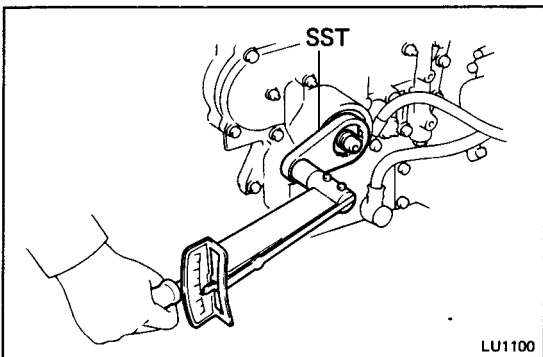

(b) Using SST, install and torque the union.

SST 09326-20011

Torque: 430 kg-cm (31 ft-lb, 42 N-m)

HINT: Use a torque wrench with a fulcrum length of 300 mm (11.81 in.).

5. INSTALL OIL FILTER (See page LU-5)

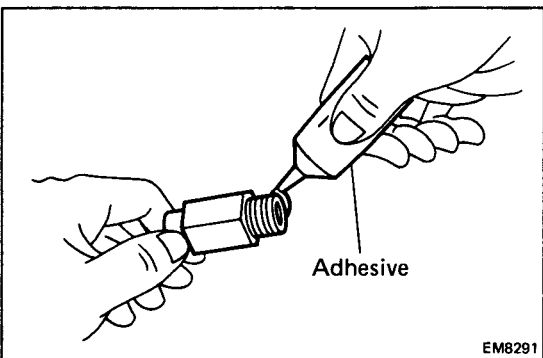

6. (LJ) INSTALL UNION BOLT

(a) Apply adhesive to two or three threads of the union bolt.

Adhesive: Part No. 08833-00070, THREE BOND 1324 or equivalent

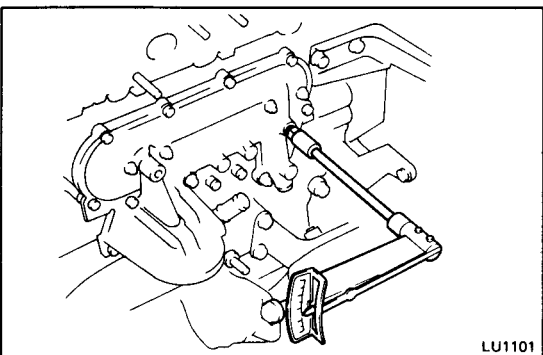

(b) Install and torque the union bolt.

Torque: 200 kg-cm (14 ft-lb, 20 N-m)

7. INSTALL ALTERNATOR**Torque:****12 mm head bolt 130 kg-cm (9 ft-lb, 12 N·m)****14 mm head bolt 510 kg-cm (37 ft-lb, 50 N·m)****8. INSPECT DRIVE BELTS****(See step 3 on page CH-3)****9. INSTALL EXHAUST MANIFOLD****(See step 6 on page EM-43)****10. (Austria)****INSTALL EGR VALVE, PIPE, VALVE ADAPTOR AND
CONTROL VALVE ASSEMBLY****(See step 8 on page EM-44)****11. INSTALL TURBOCHARGER****(See steps 3 to 8 on pages TC-13 and 14)****12. FILL WITH ENGINE COOLANT (See page CO-5)****13. START ENGINE AND CHECK FOR LEAKS****14. CHECK ENGINE OIL LEVEL (See page LU-4)**

STARTING SYSTEM

REFER TO 2L, 3L ENGINE REPAIR MANUAL
(Pub. No. RM123E)

NOTE: The following pages contain only the points which differ from the above listed manual

	Page
PRE-HEATING SYSTEM	ST-2
Super Glow Type [2L-T]	ST-2
Fixed Delay Type [3L]	ST-8
STARTER RELAY (LJ)	ST-9

ST

PRE-HEATING SYSTEM

Super Glow Type [2L-T]

SYSTEM CIRCUIT

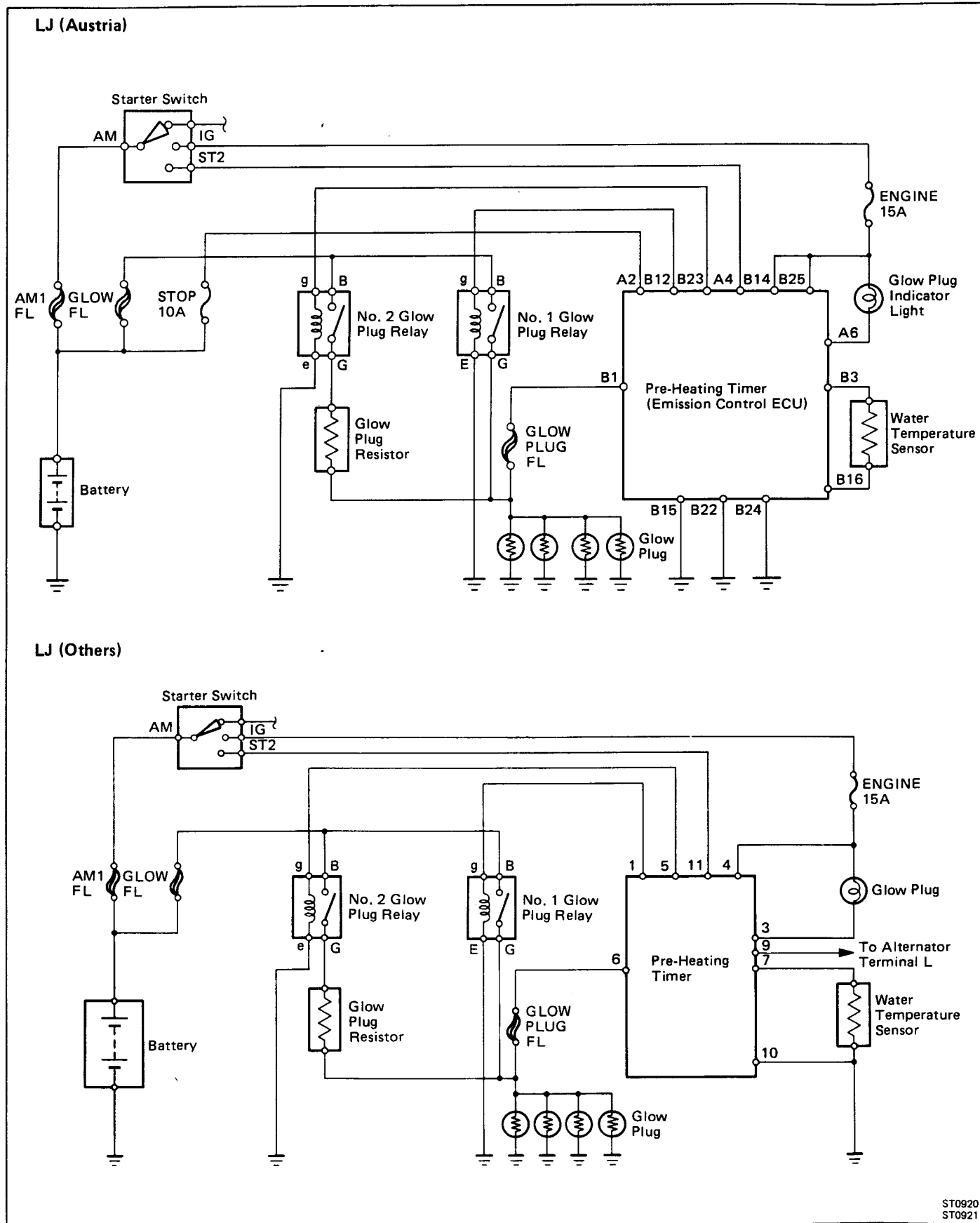

SYSTEM CIRCUIT (Cont'd)

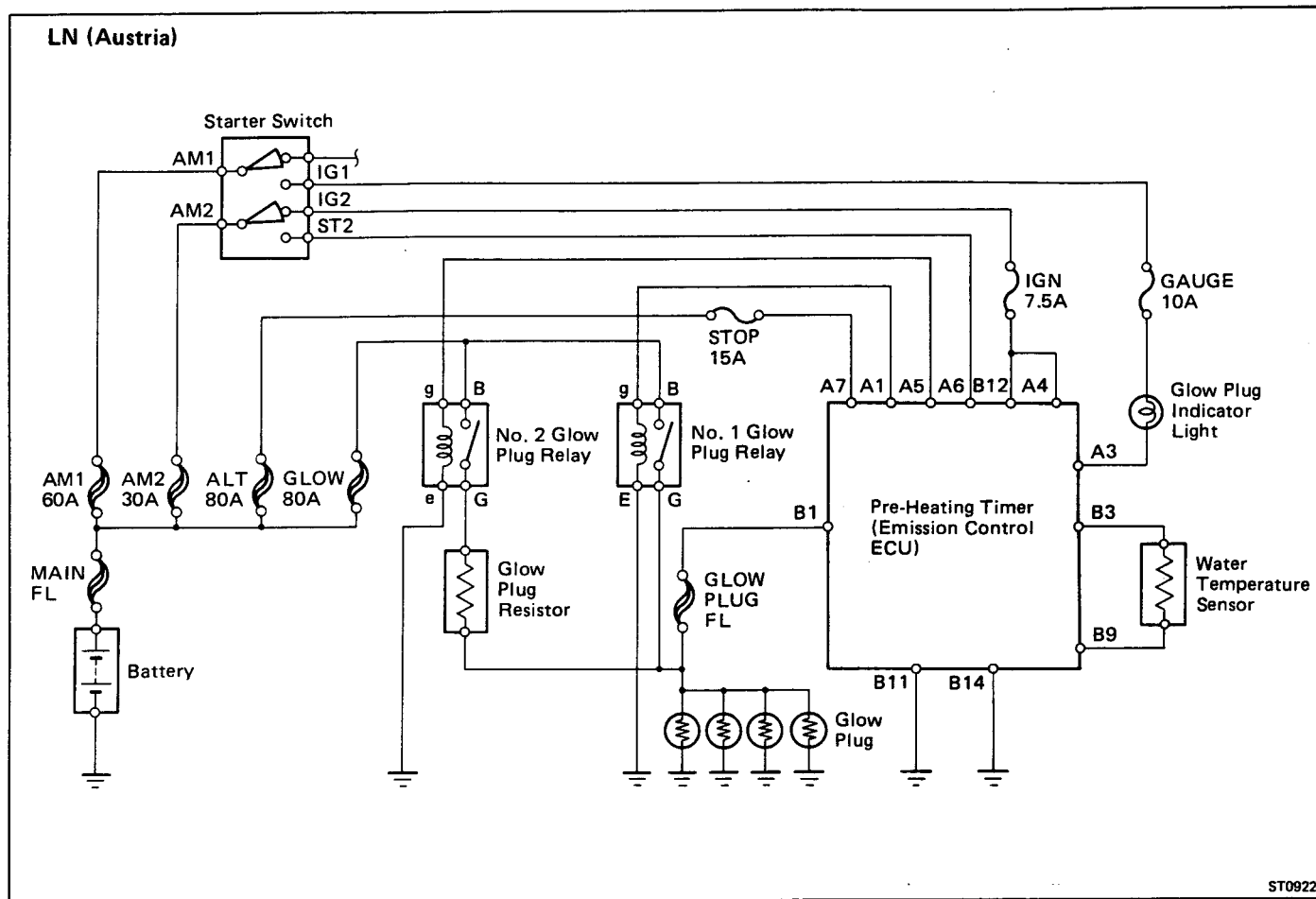

INSPECTION OF PRE-HEATING SYSTEM

HINT: Refer to Diesel Electrical System Diagnosis for inspection procedures. (See page EM-13)

INSPECT LIGHTING TIME OF GLOW INDICATOR LIGHT

Turn the starter switch ON, measure the light lighting time.

Light lighting time: Refer to chart

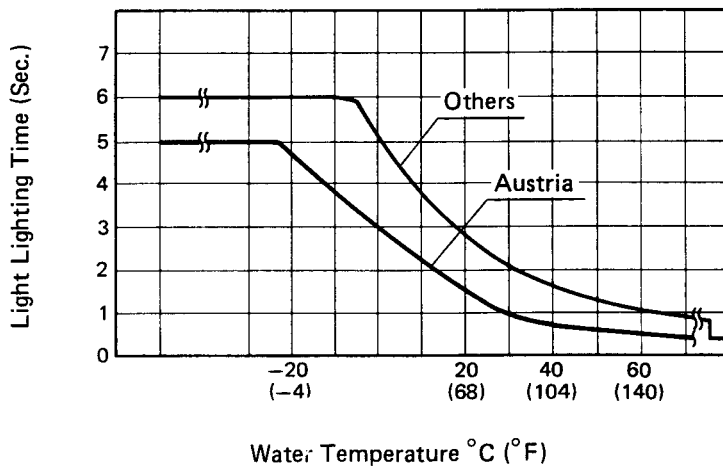

INSPECTION OF COMPONENTS

Pre-Heating Timer

LOCATION: In the cowl on the passenger side.

INSPECT PRE-HEATING TIMER CIRCUIT

Disconnect the connector from the pre-heating timer, and check the connector on the wire harness side as shown in the following chart.

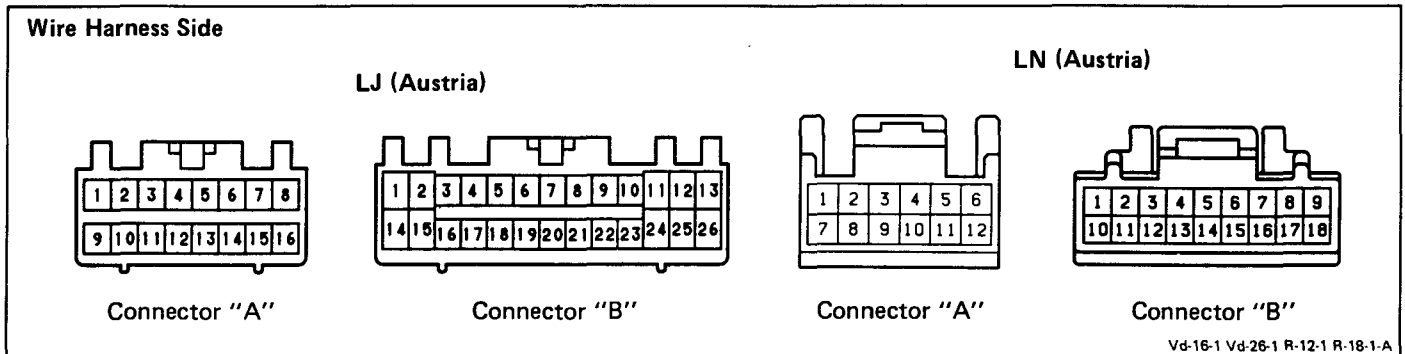

Check for	Tester connection		Condition	Specified value
	LJ	LN		
Continuity	B12	A1	– Ground	Continuity
Voltage	A2	A7	– Ground	Battery voltage
Voltage	B14	B12	– Ground	Turn starter switch OFF No voltage
			Turn starter switch ON	Battery voltage
Voltage	A6	A3	– Ground	Turn starter switch OFF No voltage
			Turn starter switch ON	Battery voltage
Continuity	B23	A5	– Ground	Continuity
Continuity	B15	B11	– Ground	Continuity
Continuity	B22	B14	– Ground	Continuity
Continuity	B24	–	– Ground	Continuity
Continuity	B3	B3	–B16(LJ), –B9(LN)	Continuity
Continuity	B16	B9	– Ground	Continuity
Voltage	A4	A6	– Ground	Turn starter switch OFF No battery
			– Ground	Turn starter switch START Battery voltage

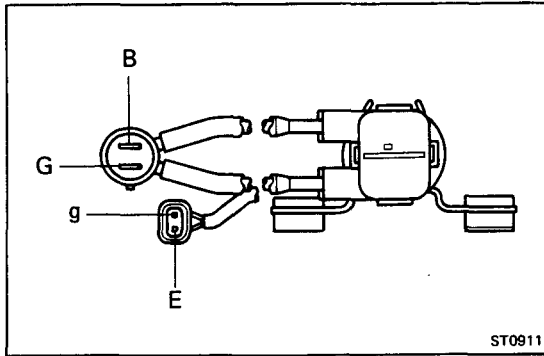

No.1 Glow Plug Relay (LJ)

LOCATION: In the engine compartment on the left side.

1. INSPECT RELAY CONTINUITY

- Using an ohmmeter, check that there is continuity between terminals E and g.
- Check that there is no continuity between terminals B and G.

If continuity is not as specified, replace the relay.

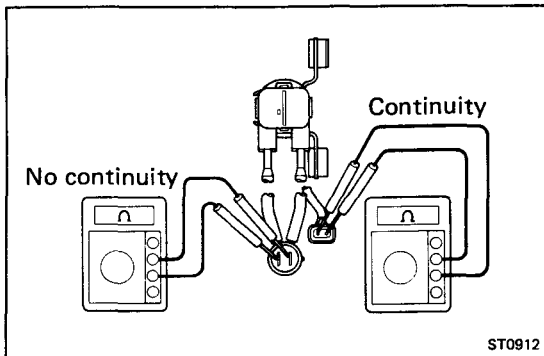

2. INSPECT RELAY OPERATION

- Apply battery voltage across terminals E and g.
- Using an ohmmeter, check that there is continuity between terminals B and G.

If operation is not as specified, replace the relay.

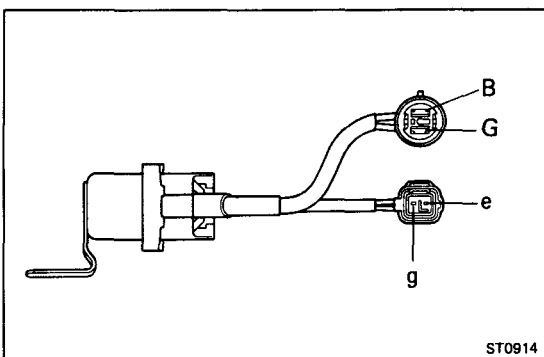
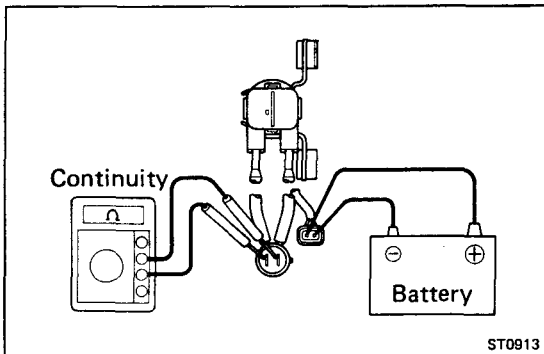

No.2 Glow Plug Relay (LJ)

LOCATION: In the engine compartment on the left side.

1. INSPECT RELAY CONTINUITY

- Using an ohmmeter, check that there is continuity between terminals e and g.
- Check that there is no continuity between terminals B and G.

If continuity is not as specified, replace the relay.

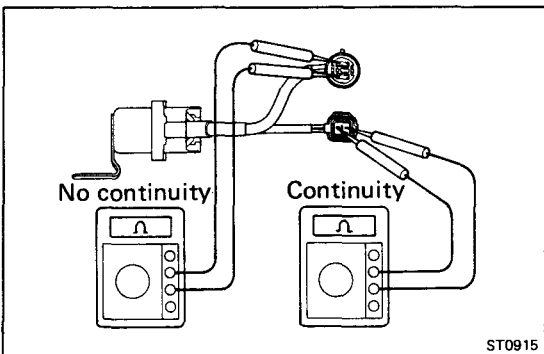

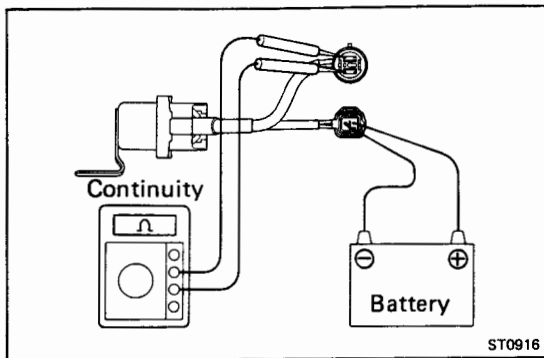

2. INSPECT RELAY OPERATION

- (a) Apply battery voltage across terminals e and g.
- (b) Using an ohmmeter, check that there is continuity between terminals B and G.

If operation is not as specified, replace the relay.

Glow Plug

INSPECT GLOW PLUG

Using an ohmmeter, check that there is continuity between the glow plug terminal and ground.

If there is no continuity, replace the glow plug.

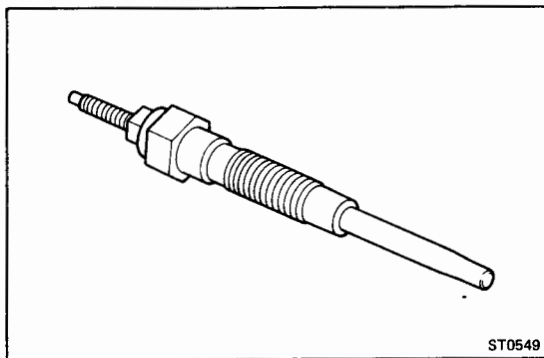
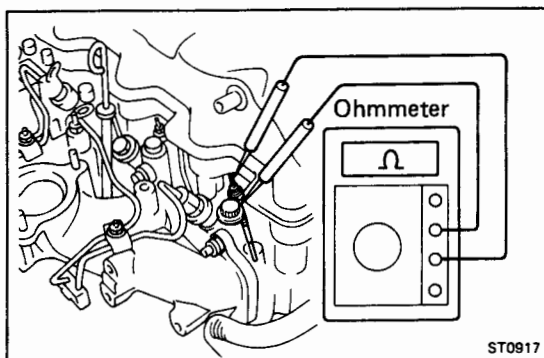

HINT:

- Be careful not to damage the glow plug pipes as it could cause an open circuit or shorten life of the plugs.
- Avoid getting oil and gasoline on the glow plug when cleaning.
- During inspection, be sure to wipe any oil off the glow plug terminal and bakelite washer with a dry cloth.
- Be careful to apply more than 11 volts to the glow plug as it could cause an open circuit.

Glow Plug Resistor

INSPECT GLOW PLUG RESISTOR

Using an ohmmeter, check that there is continuity between the resistor terminals.

If there is no continuity, replace the resistor.

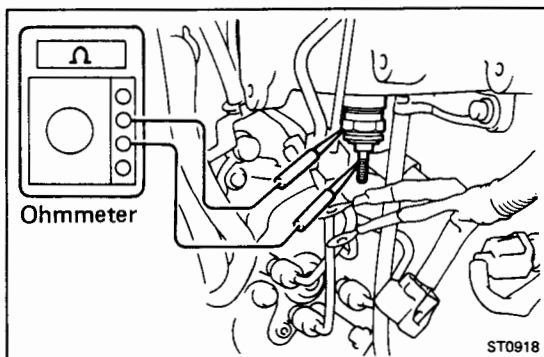

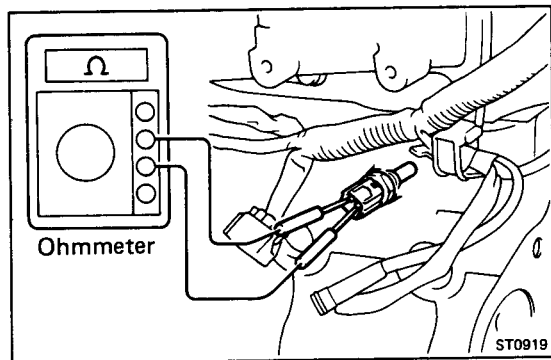

Water Temperature Sensor

INSPECT TEMPERATURE SENSOR

Using an ohmmeter, measure the resistance between the sensor terminals.

Resistance: Refer to chart

If the resistance is not as specified, replace the sensor.

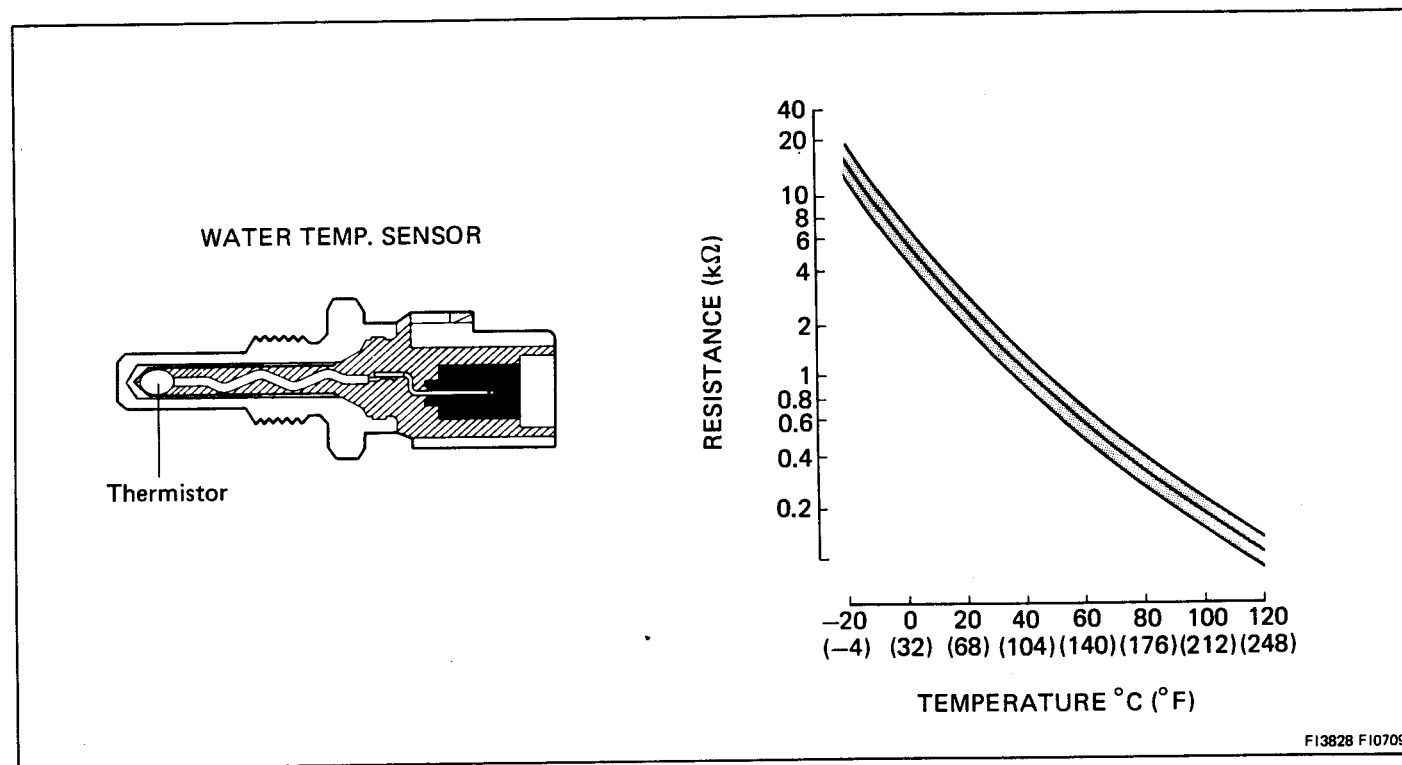

Fixed Delay Type [3L] SYSTEM CIRCUIT

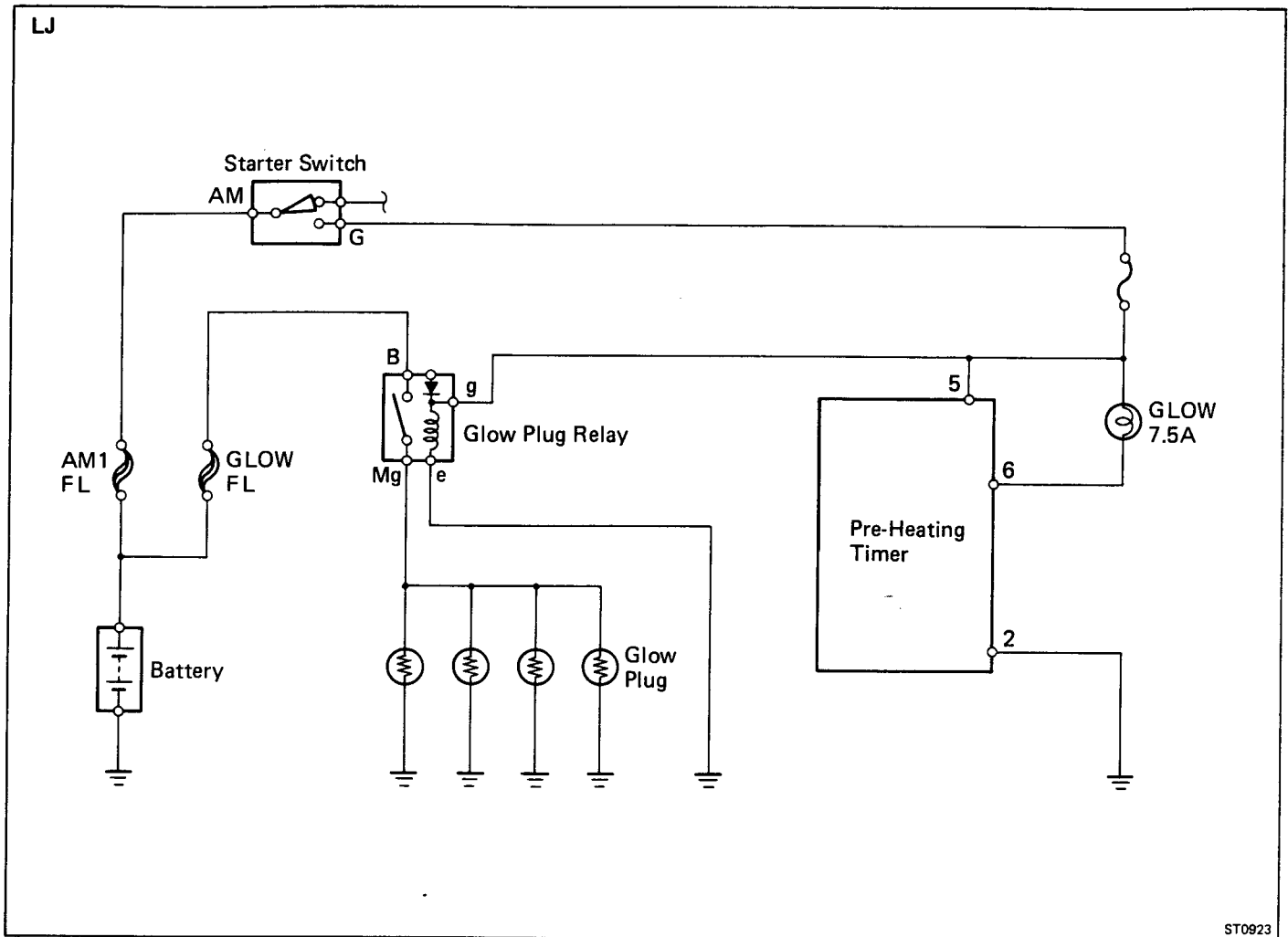

INSPECTION OF PRE-HEATING SYSTEM

INSPECT LIGHTING TIME OF GLOW INDICATOR LIGHT

Turn the starter switch GLOW, measure the light lighting time.

Light lighting time: Approx. 6 seconds

STARTER RELAY (LJ)

LOCATION: In the engine compartment on the left side.

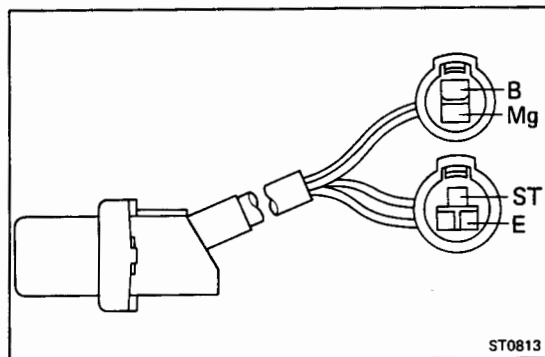
**INSPECTION OF STARTER RELAY****1. INSPECT RELAY CONTINUITY**

- (a) Using an ohmmeter, check that there is continuity between terminals E and ST.
- (b) Check that there is no continuity between terminals B and Mg.

If continuity is not as specified, replace the relay.

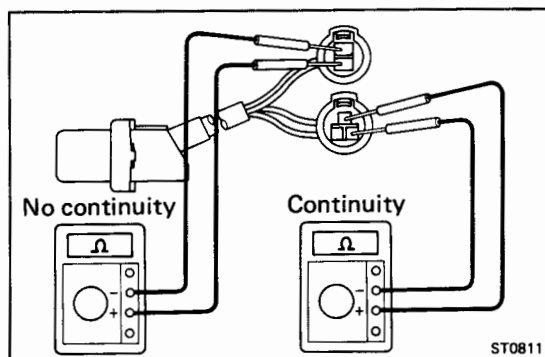
**2. INSPECT RELAY OPERATION**

- (a) Apply battery voltage across terminals E and ST.
- (b) Using an ohmmeter, check that there is continuity between terminals B and Mg.

If operation is not as specified, replace the relay.

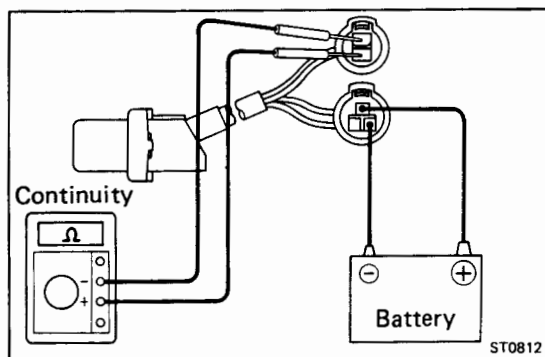

CHARGING SYSTEM

REFER TO 2L, 3L ENGINE REPAIR MANUAL
(Pub. No. RM123E)

NOTE: The following pages contain only the points which differ from the above listed manual.

	Page
CHARGING SYSTEM CIRCUIT	CH-2
ON-VEHICLE INSPECTION	CH-3

CHARGING SYSTEM CIRCUIT

LJ (w/ Hi-Speed Compact Type Alternator (w/ IC Regulator))

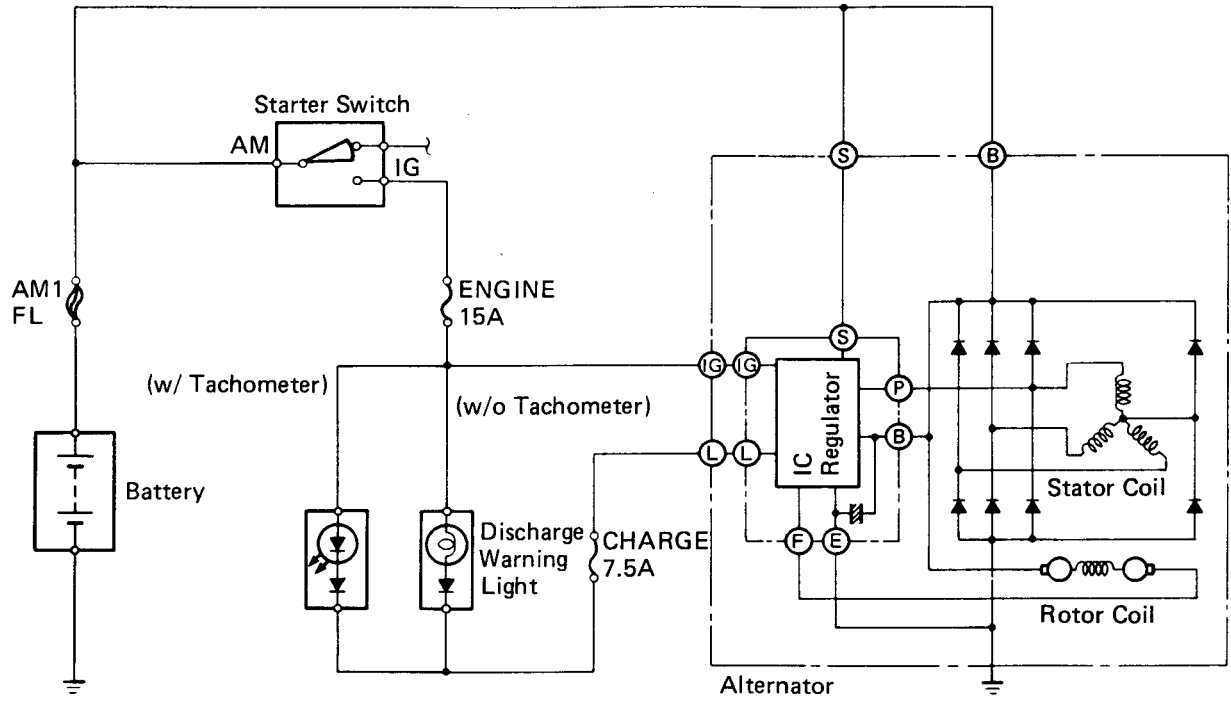

LN (w/ Conventional Type Alternator (w/o IC Regulator))

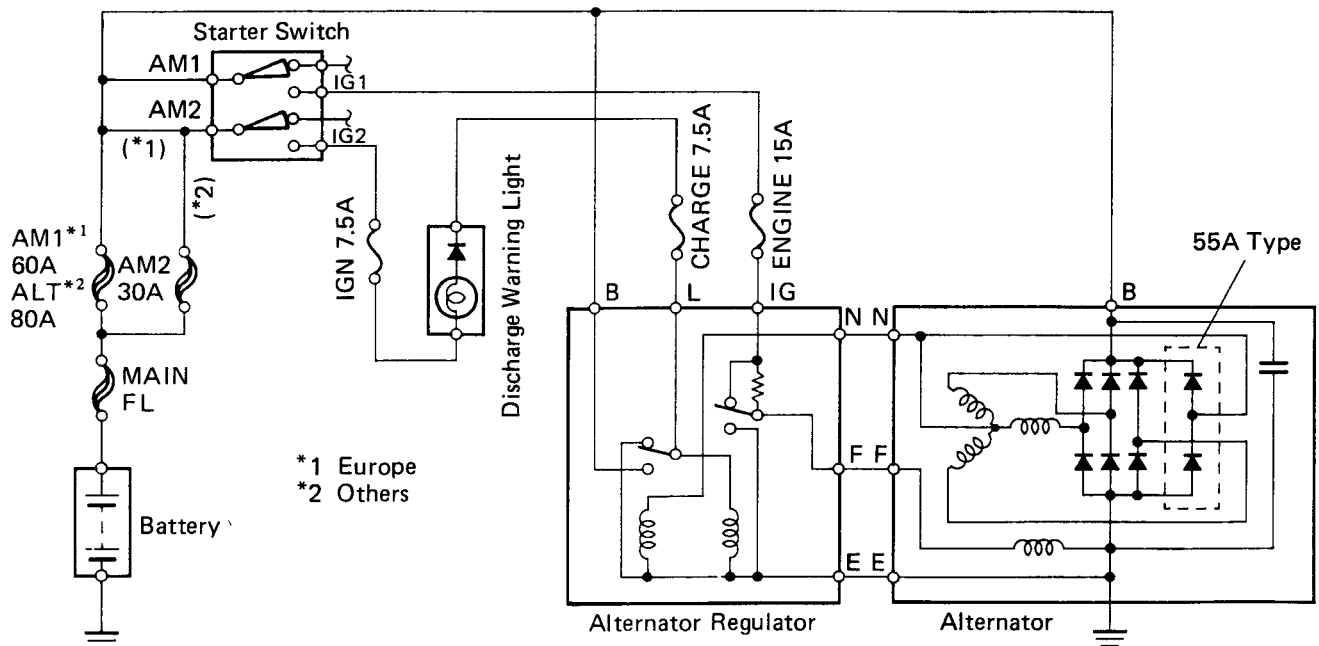

ON-VEHICLE INSPECTION

1. INSPECT BATTERY SPECIFIC GRAVITY AND ELECTROLYTE LEVEL

- (a) Check the specific gravity of each cell.

Standard specific gravity:

When fully charged at 20°C (68°F)

1.27 – 1.29 (80D26R)

1.25 – 1.27 (Others)

If not as specified, charge the battery.

- (b) Check the electrolyte quantity of each cell.

If insufficient, refill with distilled (or purified) water.

2. CHECK BATTERY TERMINALS, FUSIBLE LINKS AND FUSES

- (a) Check that the battery terminals are not loose or corroded.

- (b) Check the fusible links and fuses for continuity.

3. INSPECT DRIVE BELTS

- (a) Visually check each belt for cracks, oiliness or wear. Check that the belt does not touch the bottom of the pulley groove.

If one belt has any of the above defects, replace both belts.

- (b) Check the drive belt deflection by pressing on the belt at the points indicated in the illustration with 10 kg (22.0 lb, 98 N) of pressure.

Drive belt deflection:

New belt 7 – 10 mm (0.28 – 0.39 in.)

Used belt 10 – 15 mm (0.39 – 0.59 in.)

If the deflection is not as specified, adjust it.

HINT:

- "New belt" refers to a belt which has been used for 5 minutes or less on a running engine.
- "Used belt" refers to a belt which has been used for 5 minutes or more on a running engine.
- After installing a new belt, run the engine for about 5 minutes and recheck the deflection.

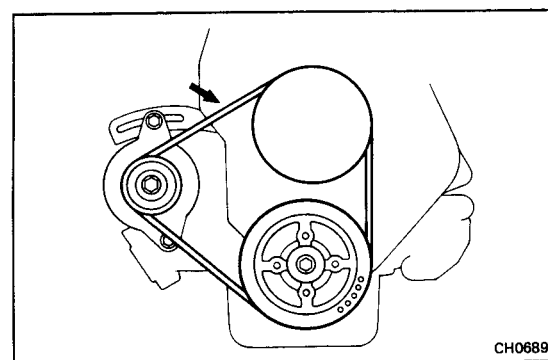
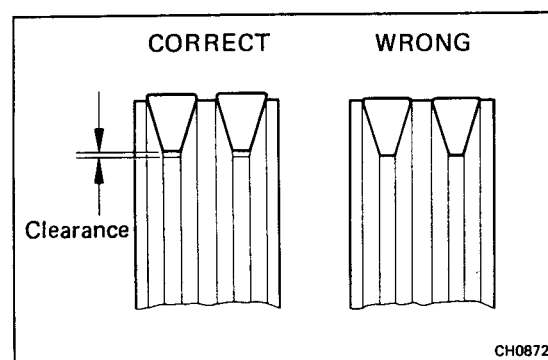
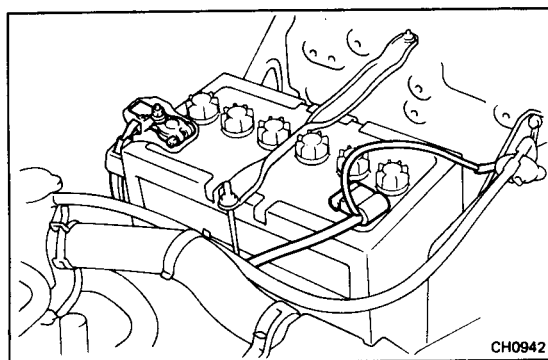
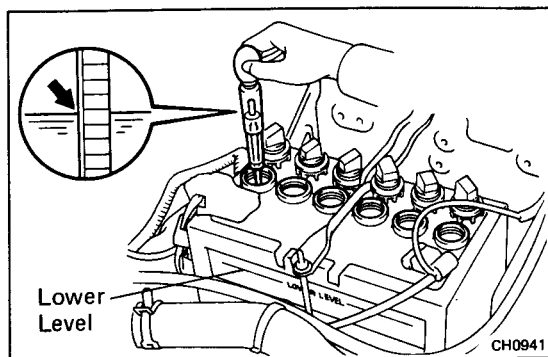

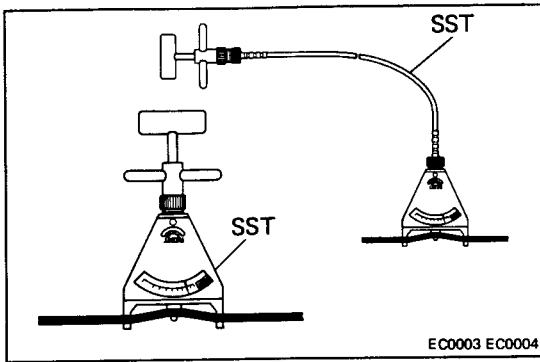

- (c) (Reference)
Using SST, measure the drive belt tension.

SST 09216-00020 and 09216-00030

Drive belt tension: New belt 40 – 60 kg
Used belt 20 – 35 kg

If the belt tension is not as specified, adjust it.

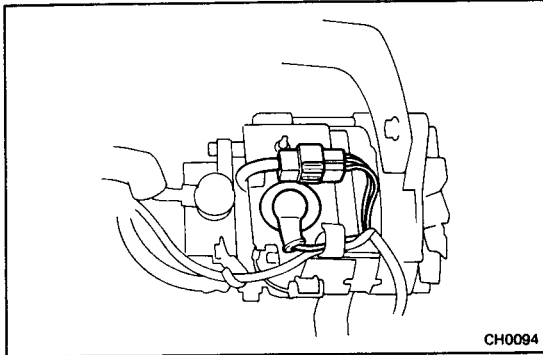

4. VISUALLY CHECK ALTERNATOR WIRING AND LISTEN FOR ABNORMAL NOISES

- Check that the wiring is in good condition.
- Check that there is no abnormal noise from the alternator while the engine is running.

5. INSPECT DISCHARGE WARNING LIGHT CIRCUIT

- Warm up the engine and then turn it off.
- Turn off all accessories.
- Turn the starter switch to "ON". Check that the discharge warning light is lit.
- Start the engine. Check that the light goes out.

If the light does not operate as specified, troubleshoot the discharge light circuit.

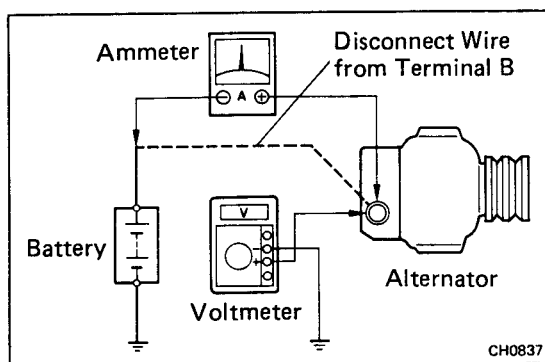

6. INSPECT CHARGING CIRCUIT WITHOUT LOAD

HINT: If a battery/alternator tester is available, connect the tester to the charging circuit as per manufacturer's instructions.

- If a tester is not available, connect a voltmeter and ammeter to the charging circuit as follows:
 - Disconnect the wire from terminal B of the alternator and connect it to the negative (–) lead of the ammeter.
 - Connect the positive (+) lead of the ammeter to terminal B of the alternator.
 - Connect the positive (+) lead of the voltmeter to terminal B of the alternator.
 - Ground the negative (–) lead of the voltmeter.

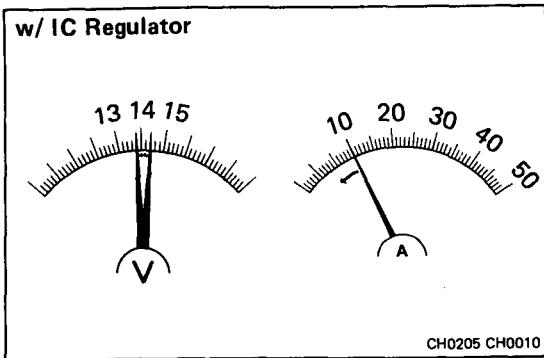

(b) Check the charging circuit as follows:
 With the engine running from idling to 2,000 rpm, check the reading on the ammeter and voltmeter.

(w/o IC Regulator)

Standard amperage: 10 A or less

Standard voltage: 13.8 – 14.4 V at 25° C (77° F)

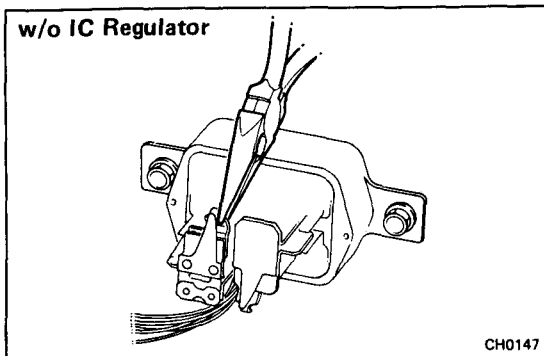

If the reading is not as standard voltage, adjust the regulator. If necessary, replace regulator.

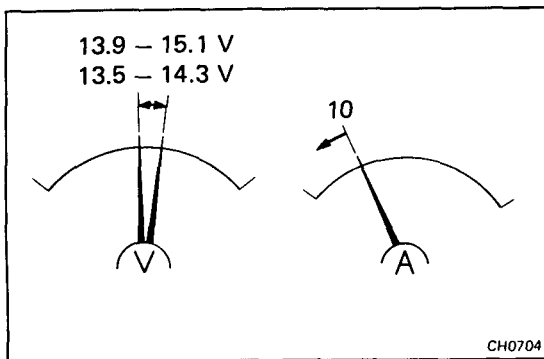

(w/ IC Regulator)

Standard amperage: 10 A or less

Standard voltage: 13.9 – 15.1 V at 25° C (77° F)

13.5 – 14.3 V at 115° C (239° F)

If the voltmeter reading is greater than standard voltage, replace the IC regulator.

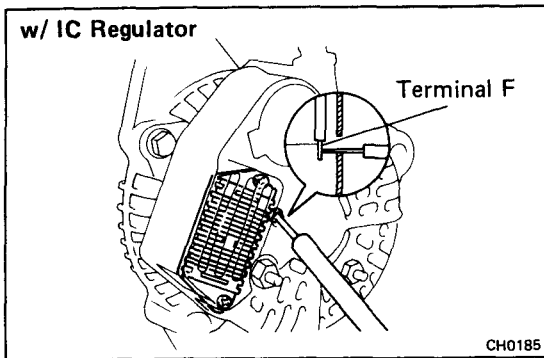

If the voltmeter reading is less than standard voltage, check the IC regulator and alternator as follows:

- With terminal F grounded, start the engine and check the voltmeter reading of terminal B.
- If the voltmeter reading is greater than standard voltage, replace the IC regulator.
- If the voltmeter reading is less than standard voltage, check the alternator.

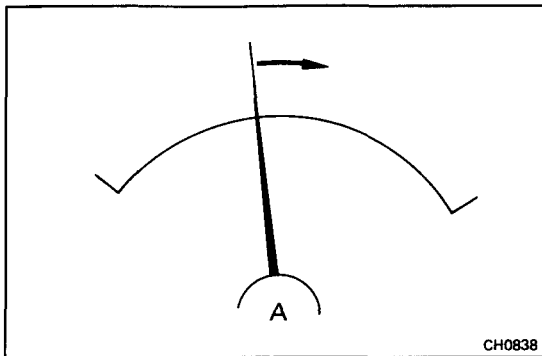

7. INSPECT CHARGING CIRCUIT WITH LOAD

(a) With the engine running at 2,000 rpm, turn on the high beam headlights and place the heater blower switch at "HI".

(b) Check the reading on the ammeter.

Standard amperage: 30 A or more

If the ammeter reading is less than standard amperage, repair the alternator.

HINT: With the battery fully charged, the indication will sometimes be less than standard amperage.

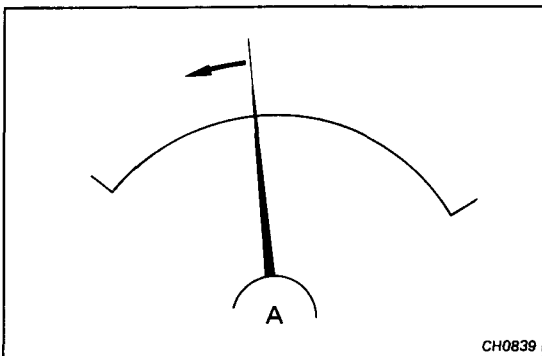

SERVICE SPECIFICATIONS

REFER TO 2L, 3L ENGINE REPAIR MANUAL
(Pub. No. RM123E)

NOTE: The following pages contain only the points which differ from the above listed manual.

	Page
ENGINE MECHANICAL	A-2
TURBOCHARGER SYSTEM	A-5
FUEL SYSTEM	A-6
COOLING SYSTEM	A-13
LUBRICATION SYSTEM	A-14
STARTING SYSTEM	A-14
CHARGING SYSTEM	A-14

ENGINE MECHANICAL

Specifications

Engine tune-up	Coolant capacity (w/o Heater)					
	LJ		10.0 liters	10.6 US qts	8.8 Imp. qts	
	LN 2L-T		8.2 liters	8.7 US qts	7.2 Imp. qts	
		3L		8.1 liters	8.6 US qts	7.1 Imp. qts
	Coolant capacity (w/ Heater)					
	LJ		10.9 liters	11.5 US qts	9.6 Imp. qts	
	LN 2L-T		9.1 liters	9.6 US qts	8.8 Imp. qts	
		3L		9.0 liters	9.5 US qts	7.9 Imp. qts
	Coolant capacity (w/ Front and rear heaters)					
	LJ		11.5 liters	12.2 US qts	10.1 Imp. qts	
	LN 2L-T		9.4 liters	9.9 US qts	8.3 Imp. qts	
		3L		9.3 liters	9.8 US qts	8.2 Imp. qts
	Engine oil capacity (LJ 2L-T)					
	Drain and refill	w/ Oil filter change		6.7 liters	7.1 US qts	5.9 Imp. qts
		w/o Oil filter change		5.7 liters	6.0 US qts	5.0 Imp. qts
		Dry fill		7.4 liters	7.8 US qts	6.5 Imp. qts
	Engine oil capacity (LJ 3L)					
	Drain and refill	w/ Oil filter change		6.7 liters	7.1 US qts	5.9 Imp. qts
		w/o Oil filter change		5.7 liters	6.0 US qts	5.0 Imp. qts
		Dry fill		7.4 liters	7.8 US qts	6.5 Imp. qts
	Engine oil capacity (LN 2L-T)					
	Drain and refill	w/ Oil filter change		6.8 liters	7.2 US qts	6.0 Imp. qts
		w/o Oil filter change		5.8 liters	6.1 US qts	5.1 Imp. qts
		Dry fill		7.5 liters	7.9 US qts	6.6 Imp. qts
	Engine oil capacity (LN 3L)					
	Drain and refill	w/ Oil filter change		5.8 liters	6.1 US qts	5.1 Imp. qts
		w/o Oil filter change		4.8 liters	5.1 US qts	4.2 Imp. qts
		Dry fill		6.5 liters	6.9 US qts	5.7 Imp. qts
	Engine oil API grade					
		2L-T		CD or better		
		3L		CC, CD or better		
	Alternator drive belt					
	Deflection	New belt		7 – 10 mm	0.28 – 0.39 in.	
	Used belt		10 – 15 mm	0.39 – 0.59 in.		
Tension (Reference)	New belt		40 – 60 kg			
	Used belt		20 – 35 kg			
Battery specific gravity						
	When fully charged at 20°C (68°F)					
		80D26R	1.27 – 1.29			
		Others	1.25 – 1.27			
Injection nozzle opening pressure						
	New nozzle		151 – 159 kg/cm ² (2,148 – 2,261 psi, 14,808 – 15,593 kPa)			
	Reused nozzle		145 – 155 kg/cm ² (2,062 – 2,205 psi, 14,220 – 15,200 kPa)			
Valve clearance						
	Intake		0.20 – 0.30 mm	0.008 – 0.012 in.		
	Exhaust		0.40 – 0.50 mm	0.016 – 0.020 in.		

Specifications (Cont'd)

<p>Engine tune-up (Cont'd)</p>	<p>New valve adjusting shim thickness</p> <p>New valve adjusting shim thickness (cont'd)</p> <p>Injection timing Plunger stroke 2L-T Austria Others 3L</p> <p>Idle speed 2L-T 3L</p> <p>Maximum speed 2L-T 3L Hong Kong, Singapore, Malaysia Others</p> <p>A/C idle-up setting speed</p> <p>Injection order</p>	<table border="0"> <tr><td>2.50 mm</td><td>0.0984 in.</td></tr> <tr><td>2.55 mm</td><td>0.1004 in.</td></tr> <tr><td>2.60 mm</td><td>0.1024 in.</td></tr> <tr><td>2.65 mm</td><td>0.1043 in.</td></tr> <tr><td>2.70 mm</td><td>0.1063 in.</td></tr> <tr><td>2.75 mm</td><td>0.1083 in.</td></tr> <tr><td>2.80 mm</td><td>0.1102 in.</td></tr> <tr><td>2.85 mm</td><td>0.1122 in.</td></tr> <tr><td>2.90 mm</td><td>0.1142 in.</td></tr> <tr><td>2.95 mm</td><td>0.1161 in.</td></tr> <tr><td>3.00 mm</td><td>0.1181 in.</td></tr> <tr><td>3.05 mm</td><td>0.1201 in.</td></tr> <tr><td>3.10 mm</td><td>0.1220 in.</td></tr> <tr><td>3.15 mm</td><td>0.1240 in.</td></tr> <tr><td>3.20 mm</td><td>0.1260 in.</td></tr> <tr><td>3.25 mm</td><td>0.1280 in.</td></tr> <tr><td>3.30 mm</td><td>0.1299 in.</td></tr> </table> <p>Within the marks of belt case and pump flange. (See page EM-24)</p> <table border="0"> <tr><td>0.54 – 0.66 mm</td><td>0.0213 – 0.0260 in.</td></tr> <tr><td>0.84 – 0.96 mm</td><td>0.0331 – 0.0378 in.</td></tr> </table> <p>750 rpm 700 rpm</p> <p>4,800 rpm 4,400 rpm 4,600 rpm 950 rpm</p> <p>1 – 3 – 4 – 2 (A – B – C – D)</p>	2.50 mm	0.0984 in.	2.55 mm	0.1004 in.	2.60 mm	0.1024 in.	2.65 mm	0.1043 in.	2.70 mm	0.1063 in.	2.75 mm	0.1083 in.	2.80 mm	0.1102 in.	2.85 mm	0.1122 in.	2.90 mm	0.1142 in.	2.95 mm	0.1161 in.	3.00 mm	0.1181 in.	3.05 mm	0.1201 in.	3.10 mm	0.1220 in.	3.15 mm	0.1240 in.	3.20 mm	0.1260 in.	3.25 mm	0.1280 in.	3.30 mm	0.1299 in.	0.54 – 0.66 mm	0.0213 – 0.0260 in.	0.84 – 0.96 mm	0.0331 – 0.0378 in.										
2.50 mm	0.0984 in.																																																	
2.55 mm	0.1004 in.																																																	
2.60 mm	0.1024 in.																																																	
2.65 mm	0.1043 in.																																																	
2.70 mm	0.1063 in.																																																	
2.75 mm	0.1083 in.																																																	
2.80 mm	0.1102 in.																																																	
2.85 mm	0.1122 in.																																																	
2.90 mm	0.1142 in.																																																	
2.95 mm	0.1161 in.																																																	
3.00 mm	0.1181 in.																																																	
3.05 mm	0.1201 in.																																																	
3.10 mm	0.1220 in.																																																	
3.15 mm	0.1240 in.																																																	
3.20 mm	0.1260 in.																																																	
3.25 mm	0.1280 in.																																																	
3.30 mm	0.1299 in.																																																	
0.54 – 0.66 mm	0.0213 – 0.0260 in.																																																	
0.84 – 0.96 mm	0.0331 – 0.0378 in.																																																	
<p>Compression pressure</p>	<p>Engine revolution at 250 rpm</p> <table border="0"> <tr><td>2L-T</td><td>STD</td></tr> <tr><td>3L</td><td>STD</td></tr> <tr><td>2L-T, 3L</td><td>Limit</td></tr> </table> <p>Difference of pressure between each cylinder</p>	2L-T	STD	3L	STD	2L-T, 3L	Limit	<p>31.0 kg/cm² (441 psi, 3,040 kPa) or more 32.0 kg/cm² (455 psi, 3,138 kPa) or more 20.0 kg/cm² (284 psi, 1,961 kPa) 5.0 kg/cm² (71 psi, 490 kPa) or less</p>																																										
2L-T	STD																																																	
3L	STD																																																	
2L-T, 3L	Limit																																																	
<p>Cylinder head</p>	<p>New cylinder head gasket thickness</p> <table border="0"> <tr><td>Mark "B"</td><td></td></tr> <tr><td>Mark "D"</td><td></td></tr> <tr><td>Mark "F"</td><td></td></tr> </table>	Mark "B"		Mark "D"		Mark "F"		<table border="0"> <tr><td>1.40 – 1.50 mm</td><td>0.0551 – 0.0591 in.</td></tr> <tr><td>1.50 – 1.60 mm</td><td>0.0591 – 0.0630 in.</td></tr> <tr><td>1.60 – 1.70 mm</td><td>0.0630 – 0.0669 in.</td></tr> </table>	1.40 – 1.50 mm	0.0551 – 0.0591 in.	1.50 – 1.60 mm	0.0591 – 0.0630 in.	1.60 – 1.70 mm	0.0630 – 0.0669 in.																																				
Mark "B"																																																		
Mark "D"																																																		
Mark "F"																																																		
1.40 – 1.50 mm	0.0551 – 0.0591 in.																																																	
1.50 – 1.60 mm	0.0591 – 0.0630 in.																																																	
1.60 – 1.70 mm	0.0630 – 0.0669 in.																																																	
<p>Camshaft</p>	<p>Cam lobe height</p> <table border="0"> <tr><td>2L-T</td><td>STD</td><td>Intake</td><td></td></tr> <tr><td></td><td></td><td>Exhaust</td><td></td></tr> <tr><td></td><td>Limit</td><td>Intake</td><td></td></tr> <tr><td></td><td></td><td>Exhaust</td><td></td></tr> <tr><td>3L</td><td>STD</td><td>Intake</td><td></td></tr> <tr><td></td><td></td><td>Exhaust</td><td></td></tr> <tr><td></td><td>Limit</td><td>Intake</td><td></td></tr> <tr><td></td><td></td><td>Exhaust</td><td></td></tr> </table>	2L-T	STD	Intake				Exhaust			Limit	Intake				Exhaust		3L	STD	Intake				Exhaust			Limit	Intake				Exhaust		<table border="0"> <tr><td>53.450 – 53.470 mm</td><td>2.1043 – 2.1051 in.</td></tr> <tr><td>54.990 – 55.010 mm</td><td>2.1650 – 2.1657 in.</td></tr> <tr><td>52.95 mm</td><td>2.0846 in.</td></tr> <tr><td>54.49 mm</td><td>2.1453 in.</td></tr> <tr><td>54.290 – 54.310 mm</td><td>2.1374 – 2.1382 in.</td></tr> <tr><td>54.990 – 55.010 mm</td><td>2.1650 – 2.1657 in.</td></tr> <tr><td>53.79 mm</td><td>2.1177 in.</td></tr> <tr><td>54.49 mm</td><td>2.1453 in.</td></tr> </table>	53.450 – 53.470 mm	2.1043 – 2.1051 in.	54.990 – 55.010 mm	2.1650 – 2.1657 in.	52.95 mm	2.0846 in.	54.49 mm	2.1453 in.	54.290 – 54.310 mm	2.1374 – 2.1382 in.	54.990 – 55.010 mm	2.1650 – 2.1657 in.	53.79 mm	2.1177 in.	54.49 mm	2.1453 in.
2L-T	STD	Intake																																																
		Exhaust																																																
	Limit	Intake																																																
		Exhaust																																																
3L	STD	Intake																																																
		Exhaust																																																
	Limit	Intake																																																
		Exhaust																																																
53.450 – 53.470 mm	2.1043 – 2.1051 in.																																																	
54.990 – 55.010 mm	2.1650 – 2.1657 in.																																																	
52.95 mm	2.0846 in.																																																	
54.49 mm	2.1453 in.																																																	
54.290 – 54.310 mm	2.1374 – 2.1382 in.																																																	
54.990 – 55.010 mm	2.1650 – 2.1657 in.																																																	
53.79 mm	2.1177 in.																																																	
54.49 mm	2.1453 in.																																																	

Specifications (Cont'd)

Cylinder block	Cylinder bore diameter	2L-T	STD	Mark "1"	92.000 – 92.010 mm	3.6220 – 3.6224 in.
				Mark "2"	92.010 – 92.020 mm	3.6224 – 3.6228 in.
				Mark "3"	92.020 – 92.030 mm	3.6228 – 3.6232 in.
		3L	Limit	STD	92.23 mm	3.6311 in.
				O/S 0.50	92.73 mm	3.6508 in.
			STD	Mark "1"	96.000 – 96.010 mm	3.7795 – 3.7799 in.
Piston and piston ring	Piston protrusion	2L-T	STD	Mark "1"	91.940 – 91.950 mm	3.6197 – 3.6201 in.
				Mark "2"	91.950 – 91.960 mm	3.6201 – 3.6205 in.
				Mark "3"	91.960 – 91.970 mm	3.6205 – 3.6209 in.
		3L	Limit	O/S 0.50	92.440 – 92.470 mm	3.6394 – 3.6405 in.
			STD	Mark "1"	95.940 – 95.950 mm	3.7772 – 3.7776 in.
				Mark "2"	95.950 – 95.960 mm	3.7776 – 3.7779 in.
Piston oil clearance	Piston diameter	2L-T	STD	Mark "1"	95.960 – 95.970 mm	3.7779 – 3.7783 in.
				Mark "2"	95.960 – 95.970 mm	3.7779 – 3.7783 in.
				Mark "3"	95.960 – 95.970 mm	3.7779 – 3.7783 in.
		3L	Limit	O/S 0.50	96.440 – 96.470 mm	3.7968 – 3.7980 in.
				STD	0.050 – 0.070 mm	0.0020 – 0.0028 in.
				Limit	0.14 mm	0.0055 in.
Piston ring groove clearance	Piston ring groove clearance	2L-T	STD	No. 1	0.028 – 0.077 mm	0.0011 – 0.0030 in.
				No. 2	0.070 – 0.115 mm	0.0028 – 0.0045 in.
				Oil	0.030 – 0.070 mm	0.0012 – 0.0028 in.
		3L	Limit	0.20 mm	0.008 in.	
			STD	No. 1	0.028 – 0.077 mm	0.0011 – 0.0030 in.
				No. 2	0.060 – 0.105 mm	0.0024 – 0.0041 in.
Connecting rod	Rod bending	Limit per 100 mm (3.94 in.)	STD	Oil	0.030 – 0.070 mm	0.0012 – 0.0028 in.
				Limit	0.20 mm	0.008 in.
				Limit	0.20 mm	0.008 in.
		Twist	Limit per 100 mm (3.94 in.)	0.05 mm	0.0020 in.	
				0.15 mm	0.0059 in.	
				0.15 mm	0.0059 in.	
Crankshaft	Connecting rod bolt outer diameter	STD	Limit	8.400 – 8.600 mm	0.3307 – 0.3386 in.	
				Limit	8.20 mm	0.3228 in.
				Limit	8.20 mm	0.3228 in.
		Bushing inside diameter	STD	29.008 – 29.020 mm	1.1420 – 1.1425 in.	
			STD	0.004 – 0.012 mm	0.0002 – 0.0005 in.	
			Limit	0.05 mm	0.0020 in.	
Piston pin oil clearance	Main journal diameter	STD	U/S 0.25	61.985 – 62.000 mm	2.4403 – 2.4409 in.	
				U/S 0.25	61.745 – 61.755 mm	2.4309 – 2.4413 in.
				U/S 0.50	61.495 – 61.505 mm	2.4211 – 2.4215 in.
		Crank pin diameter	STD	54.988 – 54.000 mm	2.1649 – 2.1654 in.	
			U/S 0.25	54.745 – 54.755 mm	2.1553 – 2.1557 in.	
			U/S 0.50	54.495 – 54.505 mm	2.1455 – 2.1459 in.	
Circle runout	Limit	0.06 mm	0.0024 in.			
	Limit	0.02 mm	0.0008 in.			
	Limit	0.02 mm	0.0008 in.			

Torque Specifications

Part tightened	kg-cm	ft-lb	N·m
Camshaft bearing cap x Cylinder head	255	18	25
Camshaft oil seal retainer x Cylinder head	185	13	18
Cylinder head x Cylinder block	800	58	78
	1st		
	2nd		
	3rd		
	90° turns		
	90° turns		
Cylinder head cover x Cylinder head	50	43 in.-lb	4.9
RH engine hanger x Cylinder head	380	27	37
Exhaust manifold x Cylinder head	530	38	52
Heat insulator x Exhaust manifold	120	9	12
Intake manifold x Cylinder head	240	17	24
EGR pipe x Intake manifold (Austria)	130	9	13
EGR valve adaptor x EGR valve (Austria)	195	14	19
LH engine hanger x Cylinder head	380	27	37
Water outlet housing x Cylinder head	195	14	19
No. 2 timing belt cover x Cylinder head	185	13	18
Connecting rod cap x Connecting rod	350	25	34
	1st		
	2nd		
	120° turns		

TURBOCHARGER SYSTEM**Specifications**

Turbocharger	Turbocharging pressure	0.61 – 0.81 kg/cm ² (8.7 – 11.5 psi, 60 – 79 kPa)
	Impeller wheel axial play	0.13 mm (0.0051 in.) or less
	Impeller wheel radial play	0.18 mm (0.0071 in.) or less

Torque Specifications

Part tightened	kg-cm	ft-lb	N·m
Turbine outlet elbow x Turbocharger	260	19	25
Turbo water pipe x Turbocharger	80	69 in.-lb	7.8
Turbocharger x Exhaust manifold	530	38	52
Turbo oil pipe x Turbocharger	195	14	19
Turbo oil pipe x Cylinder block	260	19	25
Exhaust manifold stay x Cylinder block	195	14	19
Exhaust manifold stay x Turbocharger	195	14	19
Turbocharger heat insulator x Turbocharger	120	9	12
Intake pipe x Intake manifold	120	9	12

FUEL SYSTEM

Specifications

Fuel heater	Resistance	at 20°C (68°F)	Approx. 0.7 Ω
Injection pump	Part No.		
	2L-T	Austria	22100 – 5B280
		Others	22100 – 5B270
	3L	Hong Kong, Singapore, Malaysia	22100 – 5B030
		Others	w/o HAC w/o Tacho. 22100 – 54850
			w/o HAC w/ Tacho. 22100 – 54860
			w/ HAC w/o Tacho. 22100 – 54870
			w/ HAC w/ Tacho. 22100 – 54880
		Direction of rotation	Clockwise as seen from drive side
		Injection order	1 – 3 – 4 – 2 (A – B – C – D)
		PIJ opening pressure (2L-T Austria only)	123 – 127 kg/cm ² (1,749 – 1,806 psi, 12,054 – 12,446 kPa)
		PIJ adjusting shim thickness (2L-T Austria only)	0.500 mm 0.0197 in.
			0.550 mm 0.0217 in.
			0.600 mm 0.0236 in.
			0.650 mm 0.0256 in.
			0.700 mm 0.0276 in.
			0.750 mm 0.0295 in.
			0.800 mm 0.0315 in.
			0.850 mm 0.0335 in.
			0.900 mm 0.0354 in.
			0.950 mm 0.0374 in.
			1.000 mm 0.0394 in.
			1.025 mm 0.0404 in.
			1.050 mm 0.0413 in.
			1.075 mm 0.0423 in.
			1.100 mm 0.0433 in.
			1.125 mm 0.0443 in.
		1.150 mm 0.0453 in.	
		1.175 mm 0.0463 in.	
		1.200 mm 0.0472 in.	
		1.225 mm 0.0482 in.	
		1.250 mm 0.0492 in.	
		1.275 mm 0.0502 in.	
		1.300 mm 0.0512 in.	
		1.325 mm 0.0522 in.	
		1.350 mm 0.0531 in.	
		1.375 mm 0.0541 in.	
		1.400 mm 0.0551 in.	
		1.425 mm 0.0561 in.	
		1.450 mm 0.0571 in.	
		1.475 mm 0.0581 in.	
		1.500 mm 0.0591 in.	
		1.525 mm 0.0600 in.	
		1.550 mm 0.0610 in.	
		1.575 mm 0.0620 in.	
		1.600 mm 0.0630 in.	
		1.625 mm 0.0640 in.	
		1.650 mm 0.0650 in.	
		1.675 mm 0.0659 in.	
		1.700 mm 0.0669 in.	
		1.725 mm 0.0679 in.	
		1.750 mm 0.0689 in.	

Specifications (Cont'd)

Injection pump (cont'd)	PIJ adjusting shim thickness (2L-T Austria only) (cont'd)	1.775 mm	0.0699 in.	
		1.800 mm	0.0709 in.	
		1.825 mm	0.0719 in.	
		1.850 mm	0.0728 in.	
		1.875 mm	0.0738 in.	
		1.900 mm	0.0748 in.	
		1.925 mm	0.0758 in.	
		1.950 mm	0.0768 in.	
		1.975 mm	0.0778 in.	
		2.000 mm	0.0787 in.	
		2.050 mm	0.0807 in.	
		2.100 mm	0.0827 in.	
		2.150 mm	0.0846 in.	
		2.200 mm	0.0866 in.	
		2.250 mm	0.0886 in.	
		2.300 mm	0.0906 in.	
		2.350 mm	0.0925 in.	
		2.400 mm	0.0945 in.	
		2.450 mm	0.0965 in.	
	2.500 mm	0.0984 in.		
	Spring free length			
	Delivery valve spring		24.4 mm	0.961 in.
	Plunger spring		30.0 mm	1.181 in.
	Coupling spring		16.0 mm	0.630 in.
	Pneumatic bellows spring (w/ HAC only)		35.0 mm	1.378 in.
	Boost compensator spring (2L-T only)			
	Austria			
	Sub		22.3 mm	0.878 in.
	Main		24.1 mm	0.949 in.
	Others		19.4 mm	0.764 in.
	PIJ piston lift gap (2L-T Austria only)		0.175 – 0.475 mm	0.00689 – 0.01870 in.
	Plunger stroke (2L-T Austria only)		0.60 – 0.80 mm	0.0236 – 0.0315 in.
Boost compensator adjusting shim A thickness (2L-T only)				
		1.1 mm	0.039 in.	
		1.3 mm	0.051 in.	
		1.5 mm	0.059 in.	
		1.7 mm	0.067 in.	
		1.9 mm	0.075 in.	
		2.1 mm	0.083 in.	
		2.3 mm	0.090 in.	
		2.5 mm	0.098 in.	
		2.7 mm	0.106 in.	
		2.9 mm	0.114 in.	
		3.1 mm	0.122 in.	
		3.3 mm	0.130 in.	
Boost compensator adjusting shim B thickness (2L-T Austria only)				
		12.90 mm	0.508 in.	
		13.15 mm	0.518 in.	
		13.40 mm	0.528 in.	
Boost compensator sub spring constant (2L-T Austria only)				
		1.2 kg/cm ²	1.04 lb/in.	
		1.4 kg/cm ²	1.22 lb/in.	

Injection Pump Adjustment

Preparation of pump tester	Test nozzle type		DN12SD12			
	Test nozzle opening pressure		145 – 155 kg/cm ² (2,062 – 2,205 psi, 14,220 – 15,200 kPa)			
	Injection pipe					
	Outer diameter		6.0 mm	0.236 in.		
	Inner diameter		2.0 mm	0.079 in.		
	Length		840 mm	33.07 in.		
	Minimum bending radius		25 mm (0.98 in.) or more			
	Fuel temperature		40 – 45°C			
	Fuel feeding pressure		0.2 kg/cm ² (2.8 psi, 20 kPa)			
	Fuel cut solenoid voltage		6 V			
Full load injection volume pre-setting	Item		Adjusting lever position	Pump rpm	No. of measuring strokes	Injection volume cc (cu in.)
	2L-T	Austria	Maximum speed side	1,400	200	14.04 – 14.36 (0.86 – 0.88)
		Others	Maximum speed side	1,200	200	13.94 – 14.26 (0.85 – 0.87)
	3L	Hong Kong, Singapore, Malaysia	Maximum speed side	1,200	200	10.96 – 11.28 (0.67 – 0.69)
		Others	Maximum speed side	1,200	200	11.56 – 11.88 (0.71 – 0.72)
	Maximum speed pre-setting	Item		Adjusting lever position	Pump rpm	No. of measuring strokes
2L-T		Austria	Maximum speed side	2,450	200	4.3 – 6.3 (0.26 – 0.38)
		Others	Maximum speed side	2,400	200	4.3 – 6.3 (0.26 – 0.38)
3L		Hong Kong, Singapore, Malaysia	Maximum speed side	2,200	200	4.6 – 6.2 (0.28 – 0.38)
		Others	Maximum speed side	2,300	200	4.6 – 6.2 (0.28 – 0.38)
Pump inner pressure		Pump rpm		Inner pressure kg/cm ² (psi, kPa)		
	500		3.2 – 3.8 (46 – 54, 314 – 373)			
	2,100		6.6 – 7.2 (94 – 102, 647 – 706)			
Overflow volume	Pump rpm		Overflow volume cc/min. (cu in./min.)			
	2,200		370 – 800 (22.6 – 48.8)			

Injection Pump Adjustment (Cont'd)

Automatic timer	Item		Pump rpm	Piston stroke mm (in.)		
	2L-T	Austria		800	1.2 – 2.0 (0.047 – 0.079)	
			1,200	2.5 – 3.3 (0.098 – 0.130)		
			2,000	5.4 – 6.0 (0.213 – 0.236)		
			2,300	5.4 – 6.0 (0.213 – 0.236)		
Others			800	1.4 – 2.2 (0.055 – 0.087)		
			1,200	3.0 – 3.8 (0.118 – 0.150)		
			1,800	5.5 – 6.3 (0.217 – 0.248)		
			2,300	6.7 – 7.5 (0.264 – 0.295)		
3L			800	0.6 – 1.4 (0.024 – 0.055)		
			1,200	1.8 – 2.6 (0.071 – 0.102)		
			2,000	4.4 – 5.2 (0.173 – 0.205)		
			2,300	4.7 – 5.5 (0.185 – 0.217)		
Full load injection volume	Item		Adjusting lever angle position	Pump rpm	No. of measuring strokes	Injection volume cc (cu in.)
	2L-T	Austria	Plus 23.5–33.5°	1,400	200	14.04 – 14.36 (0.86 – 0.88)
		Others	Plus 23.5–33.5°	1,200	200	13.94 – 14.26 (0.85 – 0.87)
	3L	Hong Kong, Singapore, Malaysia	Plus 23.5–33.5°	1,200	200	10.96 – 11.28 (0.67 – 0.69)
		Others	Plus 23.5–33.5°	1,200	200	11.56 – 11.88 (0.71 – 0.72)
	Maximum speed	Item		Adjusting lever angle position	Pump rpm	No. of measuring strokes
2L-T		Austria	Plus 23.5–33.5°	2,450	200	4.3 – 6.3 (0.26 – 0.38)
				2,250		8.3 – 10.5 (0.51 – 0.64)
				2,750		1.3 (0.8) or less
		Others	Plus 23.5–33.5°	2,400	200	4.3 – 6.3 (0.26 – 0.38)
				2,250		7.1 – 9.3 (0.43 – 0.57)
				2,750		1.3 (0.8) or less
3L		Hong Kong, Singapore, Malaysia	Plus 23.5–33.5°	2,200	200	4.6 – 6.2 (0.28 – 0.38)
				2,000		8.44 – 10.44 (0.52 – 0.64)
				2,400		1.3 (0.8) or less
		Others	Plus 23.5–33.5°	2,300	200	4.6 – 6.2 (0.28 – 0.38)
				2,100		9.08 – 11.08 (0.55 – 0.68)
				2,550		1.3 (0.8) or less

Injection Pump Adjustment (Cont'd)

Injection volume	Item		Adjusting lever angle position	Pump rpm	No. of measuring strokes	Injection volume cc (cu in.)	Variation limit cc (cu in.)	
2L-T	Austria		Plus 23.5–33.5°	1,400	200	13.94 – 14.26 (0.85 – 0.87)	0.4 (0.02)	
				100		13.60 – 18.40 (0.83 – 1.12)	1.2 (0.07)	
				1,200		13.70 – 15.10 (0.84 – 0.92)	0.5 (0.03)	
				1,800		12.30 – 13.70 (0.75 – 0.84)	0.5 (0.03)	
				2,000		11.60 – 12.80 (0.71 – 0.78)	0.5 (0.03)	
	Others		Plus 23.5–33.5°	1,200	200	13.94 – 14.26 (0.85 – 0.87)	0.4 (0.02)	
				100		13.60 – 18.40 (0.83 – 1.12)	1.2 (0.07)	
				1,800		12.10 – 13.10 (0.74 – 0.80)	0.5 (0.03)	
	3L	Hong Kong, Singapore, Malaysia		Plus 23.5–33.5°	1,200	200	10.96 – 11.28 (0.67 – 0.69)	0.4 (0.02)
					100		11.60 – 16.40 (0.71 – 1.00)	1.2 (0.07)
					500		9.64 – 11.04 (0.59 – 0.67)	0.5 (0.03)
					1,900		9.39 – 10.69 (0.57 – 0.65)	0.5 (0.03)
		Others		Plus 23.5–33.5°	1,200	200	11.56 – 11.88 (0.71 – 0.72)	0.4 (0.02)
					100		11.60 – 16.40 (0.71 – 1.00)	1.2 (0.07)
500					10.44 – 11.44 (0.64 – 0.70)		0.5 (0.03)	
2,000					10.19 – 11.09 (0.62 – 0.68)		0.5 (0.03)	
Governor sleeve plug head thickness				3.0 mm		0.118 in.		
				3.1 mm		0.122 in.		
				3.2 mm		0.126 in.		
				3.3 mm		0.130 in.		
				3.4 mm		0.134 in.		
				3.5 mm		0.138 in.		
				3.6 mm		0.142 in.		
				3.7 mm		0.146 in.		
				3.8 mm		0.150 in.		
				3.9 mm		0.154 in.		
				4.0 mm		0.158 in.		
				4.1 mm		0.161 in.		
				4.2 mm		0.165 in.		

Injection Pump Adjustment (Cont'd)

Full-load minimum injection volume	Item		Pump rpm	No. of measuring strokes	Injection volume cc (cu in.)			
	2L-T	Austria	1,400	200	8.8 – 10.0 (0.54 – 0.61)			
		Others	500	200	10.6 – 11.4 (0.65 – 0.70)			
Boost compensator characteristic	Item		Pump rpm	Boost pressure kg/cm ² (psi, kPa)	No. of measuring stroke	Injection volume cc (cu in.)		
	2L-T	Austria	500	0 (0, 0)	200	10.8 – 11.6 (0.65 – 0.71)		
		Others	1,200	0.41 (5.9, 40)	200	12.9 – 13.5 (0.79 – 0.82)		
Boost compensator characteristic tendency	Item		Pump rpm	Boost pressure kg/cm ² (psi, kPa)	No. of measuring strokes	Injection volume cc (cu in.)	Hysterises cc (cu in.)	
	2L-T	Austria	1,400	0.74 (10.5, 73)	200	13.84 – 14.36 (0.84 – 0.88)	–	
			1,400	0.68 (9.6, 66)		13.94 – 14.26 (0.85 – 0.87)	–	
			500	0.41 (5.9, 40)		14.60 – 15.40 (0.89 – 0.94)	0.3 (0.02) or less	
			500	0 (0, 0)		10.80 – 11.60 (0.66 – 0.71)	–	
		Others	1,200	0.74 (10.5, 73)	200	13.84 – 14.36 (0.84 – 0.88)	–	
			1,200	0.63 (9.0, 62)		13.94 – 14.26 (0.85 – 0.87)	–	
			1,200	0.41 (5.9, 40)		12.90 – 13.50 (0.79 – 0.82)	0.3 (0.02) or less	
			1,200	0.14 (2.0, 14)		11.20 – 12.00 (0.68 – 0.73)	–	
	Load sensing timer (w/o HAC)	Item		Pump rpm	No. of measuring stroke .	Injection volume cc (cu in.)		Remark
		2L-T		1,200	200	Measured value at step at (b) minus 0.6 (0.04) ± 0.4 (0.02)		Set to starting point
		3L		1,200	200	Measured value at step at (b) minus 1.0 (0.06) ± 0.4 (0.02)		
Item			Pump rpm	No. of measuring strokes	Injection volume cc (cu. in.)	Remark		
2L-T			1,200	200	8.10–8.50 (0.49–0.52)	Check ending point		
3L		Hong Kong, Singapore, Malaysia		1,200	200		8.12–8.52 (0.50–0.52)	
		Others		1,200	200		8.72–9.12 (0.52–0.56)	
Item		Pump rpm		Timer piston fluctuation mm (in.)				
2L-T		1,200		1.44 – 1.84 (0.057 – 0.072)				
3L		1,200		0.62 – 1.02 (0.024 – 0.040)				

Injection Pump Adjustment (Cont'd)

Idle speed	Item		Adjusting lever angle position	Pump rpm	No. of measuring strokes	Injection volume cc (cu in.)	Variation limit cc (cu in.)	Remarks
	2L-T	Austria	Minus 13.5 – 21.5°	375	200	q = 2.4 – 2.6 (0.15 – 0.16)	–	Pre-set
350				q plus 0.5 (0.03) or more		–	–	
450				q minus 1.1–2.1 (0.07 – 0.13)		–	–	
375				3.0 – 4.0 (0.18 – 0.24)		0.34 (0.02)	Adjust	
Others		Minus 13.5 – 21.5°	375	200	q = 1.5 – 2.5 (0.09 – 0.15)	–	Pre-set	
			350		q plus 0.5 (0.03) or more	–	–	
			450		q minus 0.7–1.7 (0.04 – 0.10)	–	–	
			375		1.8 – 2.8 (0.11 – 0.17)	0.34 (0.02)	Adjust	
3L		Minus 12.5 – 22.5°	350	200	1.8 – 2.8 (0.11 – 0.17)	0.34 (0.02)	Adjust	
			525		1.2 (0.07) or less	–	–	
Dash pot	Item		Pump rpm	No. of measuring strokes	Injection volume cc (cu in.)	Remarks		
	2L-T	Austria	600	200	q = 0.5 – 0.7 (0.03 – 0.04)	Lever set		
600			200	q plus 0.2 – 0.4 (0.01 – 0.02)	Adjust			
Others		600	200	q = 0.6 – 0.8 (0.04 – 0.05)	Lever set			
		600	200	q plus 0.2 – 0.4 (0.01 – 0.02)	Adjust			
Cold start system	Item		Fuel temp. °C (°F)	Timer piston stroke mm (in.)				
	2L-T	Austria	25 (77)	0.7 – 0.9 (0.028 – 0.035)				
		Others	25 (77)	1.3 – 1.5 (0.051 – 0.059)				
Fast idle	Item		Fuel temp. °C (°F)	Clearance mm (in.)				
	2L-T		20 (68)	2.5 (0.098)				
			50 (122)	0 (0)				
Adjusting lever	Item		Lever moving angle					
	2L-T		41 – 51°					
	3L		43 – 49°					

Torque Specifications

Part tightened	kg-cm	ft-lb	N·m
Retaining nut x Holder body (2L-T Austria)	675	49	66
Distributive head plug x Distributive head	700	51	69
Pilot injection actuator x Distributive head (2L-T Austria)	900	65	88
Governor cover x Injection pump body	85	74 in.-lb	8.3
Fuel cut solenoid x Distributive head	225	16	22
Pickup sensor x Injection pump body	210	15	21
Fuel inlet pipe x Injection pump	250	18	25
Fuel outlet pipe x Injection pump	250	18	25
Injection pump x Timing belt case	210	15	21
Pump stay x Injection pump	185	13	18
Pump stay x Cylinder block	185	13	18
Injection pipe x Injection nozzle	250	18	25
Injection pipe x Injection pump	250	18	25
Injection pump drive pulley x Injection pump	650	47	64
Crankshaft timing pulley x Crankshaft	1,700	123	167

COOLING SYSTEM**Specifications**

Engine coolant capacity		See page A-2
Radiator cap	Relief valve opening pressure	STD
		Limit
		0.75 – 1.05 kg/cm ² (10.7 – 14.9 psi, 74 – 103 kPa)
		0.6 kg/cm ² (8.5 psi, 59 kPa)
Thermostat	Valve opening temperature	86 – 90°C 187 – 194°F
	Valve lift	at 100°C (212°F)
		8 mm (0.31 in.) or more

Torque Specifications

Part tightened	kg-cm	ft-lb	N·m
Cylinder block x Drain plug	300	22	29
Water outlet x Water outlet housing	195	14	19

LUBRICATION SYSTEM

Specifications

Engine oil capacity	See page A-2	
Oil pressure	at idling at 3000 rpm	0.3 kg/cm ² (4.3 psi, 29 kPa) or more 3.0 – 5.5 kg/cm ² (43 – 78 psi, 294 – 539 kPa)

Torque specifications

Part tightened	kg-cm	ft-lb	N·m
Engine oil drain plug	400	29	39
Oil cooler x Oil filter bracket	145	10	14
Oil cooler bracket x Cylinder block Bolt	195	14	19
Oil cooler bracket x Cylinder block Nut	210	15	21
Relief valve plug x Oil filter bracket	370	27	36
Union x Oil filter bracket (2L-T)	500	36	49
Union bolt x Oil filter bracket (LJ 2L-T)	200	14	20
Alternator x Engine RH mounting bracket 14 mm head bolt	510	37	50
Alternator x Fan belt adjusting bar 12 mm head bolt	130	9	12

STARTING SYSTEM

Pre-heating system	Light lighting time	See page ST-3 Approx. 6 seconds	
	Supper glow type		
	Fixed delay type		
	Water temp. sensor resistance		
	at -20°C (-4°F)		10 – 20 kΩ
	at 0°C (32°F)		4 – 7 kΩ
	at 20°C (68°F)		2 – 3 kΩ
at 40°C (104°F)	0.9 – 1.3 kΩ		
at 60°C (140°F)	0.4 – 0.7 kΩ		
at 80°C (176°F)	0.2 – 0.4 kΩ		

CHARGING SYSTEM

Drive belt deflection and tension	See page A-2	
Battery specific gravity when fully charged at 20°C (68°F)	80D26R	1.27 – 1.29
	Others	1.25 – 1.27
Alternator regulator	Regulating voltage	13.8 – 14.4 V 13.9 – 15.1 V 13.5 – 14.3 V
	w/o IC regulator at 25°C (77°F)	
	w/ IC regulator at 25°C (77°F)	
	at 115°C (239°F)	







STANDARD BOLT TORQUE SPECIFICATIONS

	Page
STANDARD BOLT TORQUE SPECIFICATIONS	B-2

B

STANDARD BOLT TORQUE SPECIFICATIONS

HOW TO DETERMINE BOLT STRENGTH

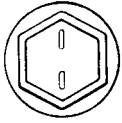
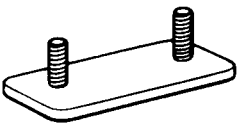
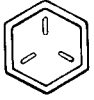
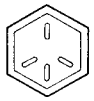
	Mark	Class		Mark	Class
Hexagon head bolt	 <p>Bolt head No.</p> <p>4 — 4T 5 — 5T 6 — 6T 7 — 7T 8 — 8T 9 — 9T 10 — 10T 11 — 11T</p>		Stud bolt	 <p>No mark</p>	4T
	 <p>No mark</p>	4T			
Hexagon flange bolt w/ washer hexagon bolt	 <p>No mark</p>	4T	Welded bolt	 <p>Grooved</p>	6T
Hexagon head bolt	 <p>Two protruding lines</p>	5T			
Hexagon flange bolt w/ washer hexagon bolt	 <p>Two protruding lines</p>	6T		4T	
Hexagon head bolt	 <p>Three protruding lines</p>	7T			
Hexagon head bolt	 <p>Four protruding lines</p>	8T			

SPECIFIED TORQUE FOR STANDARD BOLTS

Class	Diameter mm	Pitch mm	Specified torque					
			Hexagon head bolt			Hexagon flange bolt		
			kg-cm	ft-lb	N·m	kg-cm	ft-lb	N·m
4T	6	1	55	48 in.-lb	5	60	52 in.-lb	6
	8	1.25	130	9	12.5	145	10	14
	10	1.25	260	19	26	290	21	29
	12	1.25	480	35	47	540	39	53
	14	1.5	760	55	74	850	61	84
	16	1.5	1,150	83	115	—	—	—
5T	6	1	65	56 in.-lb	6.5	75	65 in.-lb	7.5
	8	1.25	160	12	15.5	175	13	17.5
	10	1.25	330	24	32	360	26	36
	12	1.25	600	43	59	670	48	65
	14	1.5	930	67	91	1,050	76	100
	16	1.5	1,400	101	140	—	—	—
6T	6	1	80	69 in.-lb	8	90	78 in.-lb	9
	8	1.25	195	14	19	210	15	21
	10	1.25	400	29	39	440	32	44
	12	1.25	730	53	71	810	59	80
	14	1.5	1,100	80	110	1,250	90	125
	16	1.5	1,750	127	170	—	—	—
7T	6	1	110	8	10.5	120	9	12
	8	1.25	260	19	25	290	21	28
	10	1.25	530	38	52	590	43	58
	12	1.25	970	70	95	1,050	76	105
	14	1.5	1,500	108	145	1,700	123	165
	16	1.5	2,300	166	230	—	—	—
8T	8	1.25	300	22	29	330	24	33
	10	1.25	620	45	61	690	50	68
	12	1.25	1,100	80	110	1,250	90	120
9T	8	1.25	340	25	34	380	27	37
	10	1.25	710	51	70	790	57	78
	12	1.25	1,300	94	125	1,450	105	140
10T	8	1.25	390	28	38	430	31	42
	10	1.25	800	58	78	890	64	88
	12	1.25	1,450	105	140	1,600	116	155
11T	8	1.25	430	31	42	480	35	47
	10	1.25	890	64	87	990	72	97
	12	1.25	1,600	116	155	1,800	130	175







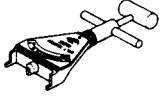
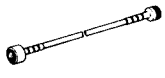

SST AND SSM

REFER TO 2L, 3L ENGINE REPAIR MANUAL
(Pub. No. RM123E)

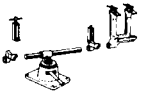

NOTE: The following pages contain only the points which differ from the above listed manual.

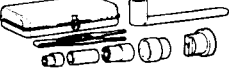
	Page
SST (SPECIAL SERVICE TOOLS)	C-2
SSM (SPECIAL SERVICE MATERIALS)	C-2

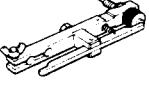
SST (SPECIAL SERVICE TOOLS)

Section											
Part Name						EM	TC	FU	LU	CH	Note
Part No.											
Illustration											
	09027-12140	Angled Open End Wrench 12 x 14 mm							●		w/ Sender gauge
	09216-00020	Belt Tension Gauge								●	
	09216-00030	Belt Tension Gauge Cable								●	
	09228-10001	Oil Filter Wrench							●		w/ By-pass element type
	09228-44011	Oil Filter Wrench							●		Full flow type
	09236-00101	Water Pump Overhaul Tool Set						●			
	(09237-00070)	(Shaft "C")						●			Governor sleeve plug
	09241-76022	Injection Pump Stand Set						●			
	09245-54010	Injection Pump Stand Arm						●			
	09248-64010	Valve Clearance Adjusting Tool				●					
	09260-54012	Injection Pump Tool Set						●			
	(09262-54010)	(Distributor Head Plug) Wrench									
	(09269-54020)	(Socket 14 mm)									
	09275-54010	Plunger Stroke Measuring Tool				●		●			

SST (SPECIAL SERVICE TOOLS) (Cont'd)

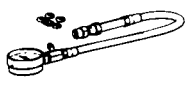
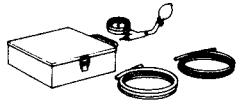
Section	Part Name	Part No.	Illustration	EM	TC	FU	LU	CH	Note
							●		Union
				●					
				●					
				●					
					●	●			

SSM (SPECIAL SERVICE MATERIALS)

Part Name	Part No.	Sec.	Use etc.
Seal packing or equivalent	08826-00080	EM	Cylinder head cover Half circulator plug
Adhesive 1324, Three bond 1324 or equivalent	08833-00070	LU	Union Union bolt
Adhesive 1344, Three bond 1344, Loctite 242 or equivalent	08833-00080	LU	Oil pressure switch or sender gauge